

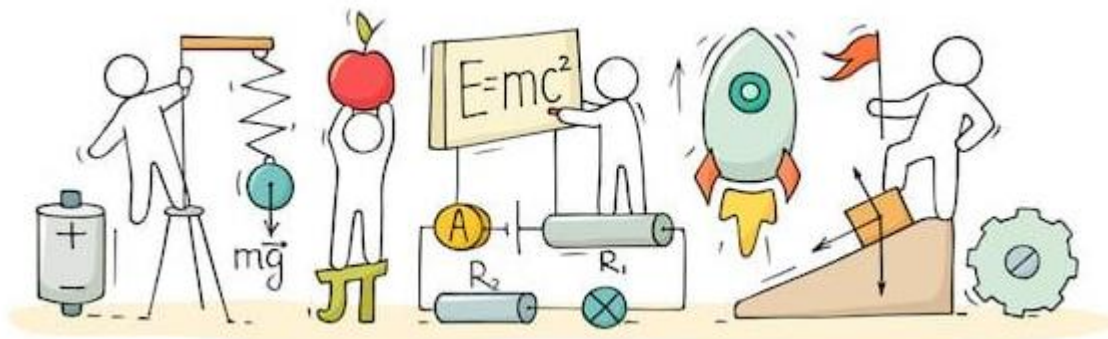

C V RAMAN
PUCOLLEGE
INDI

CHAPTER 1: ELECTRIC CHARGES AND FIELDS



ELECTRIC CHARGES AND FIELDS

Introduction:

Study of static charges is called electrostatics and this complete electrostatic will be discussed in two chapters. In this chapter we begin with a discussion of electric charge, some properties of charged bodies, and fundamental electric force between two charged bodies.

What is Electric Charge?

Electric Charge is a fundamental property of a matter which is responsible for electric forces between the bodies. Two electrons placed at small separation are found to repel each other, this repulsive force (Electric force) is only because of electric charge on electrons.

When a glass rod is rubbed with silk, the rod acquires one kind of charge, and the silk acquires the second kind of charge. This is true for any pair of objects that are rubbed to be electrified. Now if the electrified glass rod is brought in contact with silk, with which it was rubbed, they no longer attract each other.

Types of Electric Charge:

There are two types of charge exist in our nature.

- Positive Charge
- Negative Charge

If any object loses their electrons then they get positive charge. It is denoted by (+q) sign. If any object gain electrons from another object, then they get negative charge. It is denoted by (-q) sign. The charges were named as positive and negative by the American scientist Benjamin Franklin. If an object possesses an electric charge, it is said to be electrified or charged. When it has no charge it is said to be neutral.

Basic Properties of Electric Charge:

The important properties and characteristic of electric charge are given below.

Attraction and Repulsion: Like charges repel each other while unlike charges attract each other.

Electric Induction: When a charged object brings to contact with another uncharged, it gets opposite charge of charged object. It is called charging by induction.

Charge is Quantized: An object that is electrically charged has an excess or deficiency of some whole number of electrons. Since, electrons cannot be divided into fraction of electrons, it means that the charge of an object is a whole-number multiple of the charge of an electron. For example, it cannot have a charge equal to the charge of 0.5 or 1000.5 electrons.

Mathematically $q = \pm ne$, here $n = 1, 2, 3$ and $e = 1.6 \times 10^{-19}$ coulomb.

Electric Charge is Conserved: According to this property, "An electric charge neither can be created nor can be destroyed" i.e., total net charge of an isolated system is always conserved. Thus, when a glass rod rubbed with silk cloth, both glass rod and silk cloth acquire opposite charge in same quantity. Thus, total amount of charge remains same before rubbing as well as after rubbing.

Conductors and Insulators:

Some substances easily allow passage of electricity through them while others do not. Substances which allow electricity to pass through them easily are called 'conductors'. They have electrons that are free to move inside the material. Metals, human and animal bodies, earth etc. are example of conductors. Non-metals e.g., glass, plastic, wood are 'insulators' because they do not easily allow passage of electricity through them.

Most substances are either conductors or insulators. There is a third category called 'semiconductors' which are intermediate between conductors and insulators because they partially allow movement of charges through them.

Charging by Induction:

Now as we know that two oppositely charged bodies attract each other. But it also has been our observation that a charged body attracts a neutral body as well. This is explained on the basis of charging by induction. In induction process two bodies (at least one body must be charged) are brought very close, but they never touch each other.

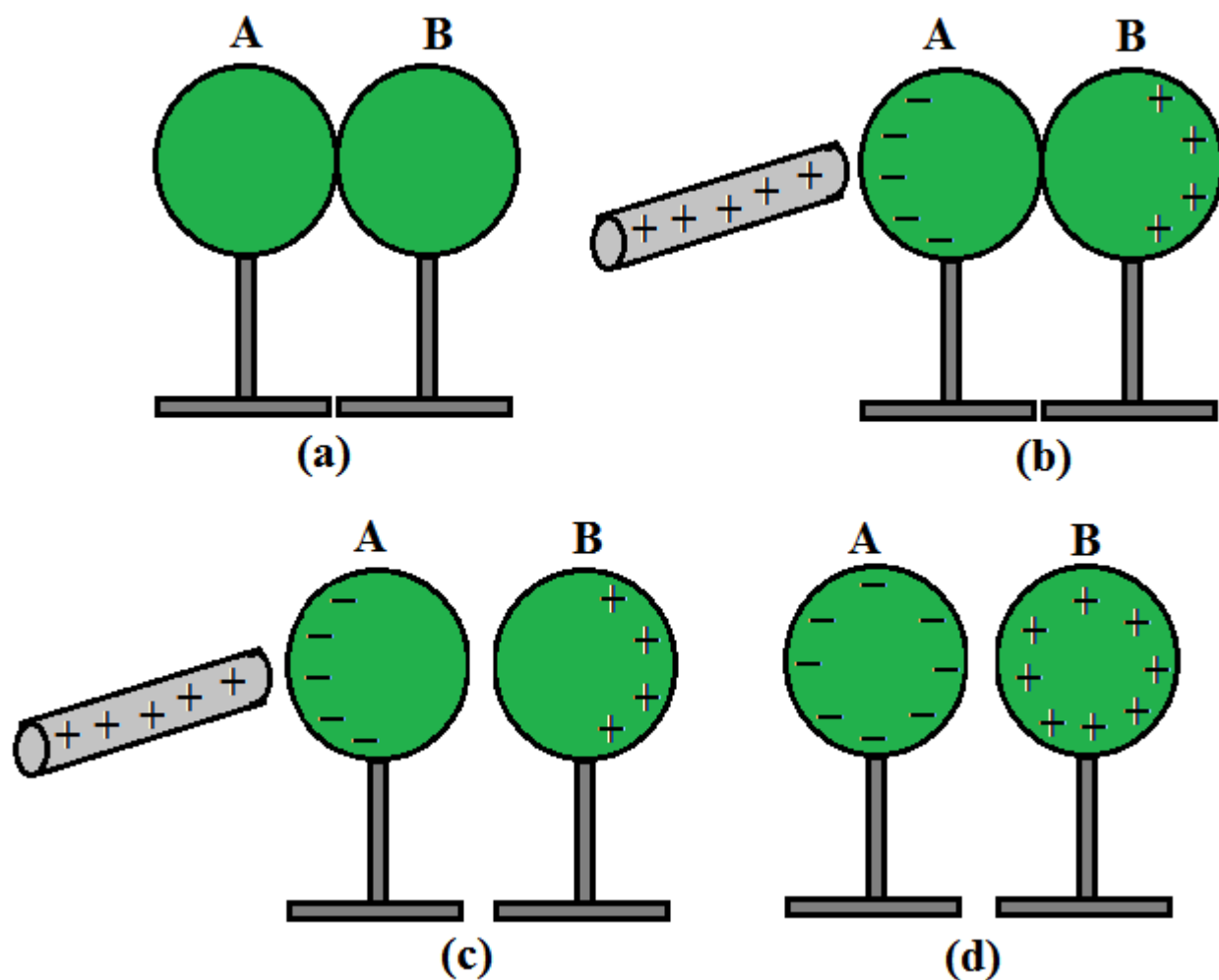

Let us examine how a charged body attracts an uncharged body. Imagine a conducting or partially conducting body (sphere here) is kept on an insulating stand and a charged rod (positive, for example) is brought very close to it. It will attract electrons to its side and the farther end of the sphere will become positively charged as it is deficient of electrons.

Coulomb's Law:

- In 1785 Charles Coulomb (1736-1806) experimentally established the fundamental law of electric force between two stationary charged particles. He observed that An electric force between two charge particles has the following properties:
- It is directed along a line joining the two particles and is inversely proportional to the square of the separation distance r , between them.
- It is proportional to the product of the magnitudes of the charges, $|q_1|$ and $|q_2|$, of the two particles.
- It is attractive if the charges are of opposite sign and repulsive if the charges have the same sign.

From these observations, Coulomb proposed the following mathematical form for the electric force between two charges. The magnitude of the electric force F between charges q_1 and q_2 separated by a distance r is given by

$$F = k \frac{|q_1||q_2|}{r^2}$$

where k is a constant called the Coulomb constant. The proportionality constant k in Coulomb's law is similar to G in Newton's law of gravitation. Instead of being a very small number like G (6.67×10^{-11}), the electrical proportionality constant k is a very large number. It is approximately.

$$k = 8.9875 \times 10^9 \text{ N}\cdot\text{m}^2\text{C}^{-2}$$

The constant k is often written in terms of another constant, ϵ_0 , called the permittivity of free space. It is related to k by

$$k = \frac{1}{4\pi\epsilon_0}$$

$$\therefore F = \frac{1}{4\pi\epsilon_0} \frac{|q_1||q_2|}{r^2}$$

$$\epsilon_0 = \frac{1}{4\pi k} = 8.85 \times \frac{10^{-12}\text{C}^2}{\text{Nm}^2}$$

Coulomb's Laws of Electrostatics

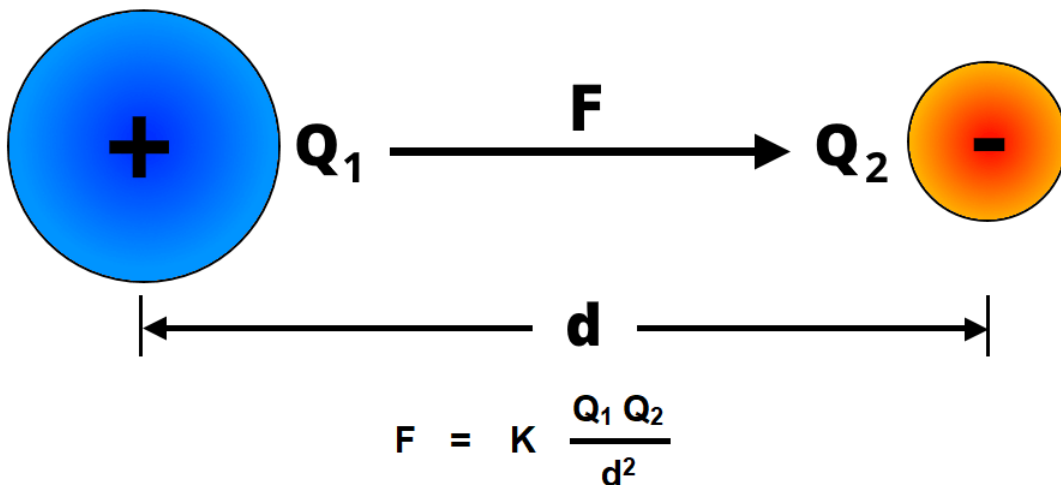

Electric Field:

A charge produces something called an electric field in the space around it and this electric field exerts a force on any charge (except the source charge itself) placed in it. The electric field has its own existence and is present even if there is no additional charge to experience the force.

Intensity of Electric Field:

Intensity of electric field due to a charge configuration at a point is defined as the force acting on a unit positive charge at this point. Hence if a charge q experiences an electric force F at a point then intensity of electric field at this point is given as

$$E = \frac{F}{q}$$

It has S.I. units of newtons per coulomb (N/C).

Electric Field due to a Point Charge:

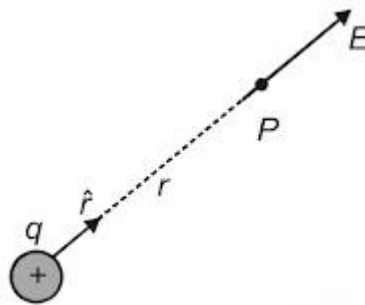

To determine the direction of an electric field, consider a point charge q as a source charge. This charge creates an electric field at all points in space surrounding it. A test charge q_0 is placed at point P , a distance r from the source charge. According to Coulomb's law, the force exerted by q on the test charge is.

$$F = \frac{1}{4\pi\epsilon_0} \frac{qq_0}{r^2}$$

This force is directed away from the source charge q , since the electric field at P , the position of the test charge, is defined by

$$E = \frac{F}{q_0}$$

we find that at P , the electric field created by q is

$$E = \frac{1}{4\pi\epsilon_0} \frac{q}{r^2}$$

Electric Field Lines:

Electric field lines are a way of pictorially mapping the electric field around a configuration of charges. An electric field line is, in general, a curve drawn in such a way that the tangent to it at each point is in the direction of the net field at that point.

The field lines follow some important general properties:

- The tangent to electric field lines at any point gives the direction of electric field at that point.
- In free space, they are continuous curves which emerge from positive charge and terminate at negative charge
- They do not intersect each other. If they do so, then it would mean two directions of electric field at the point of intersection, which is not possible.
- Electrostatic field lines do not form any closed loops. This follows from the conservative nature of electric field.

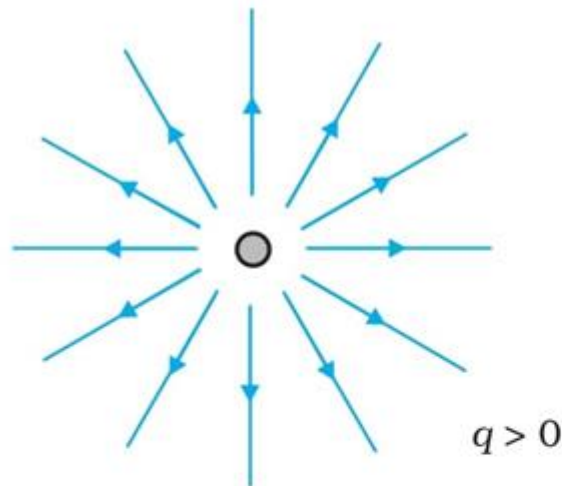

(a)

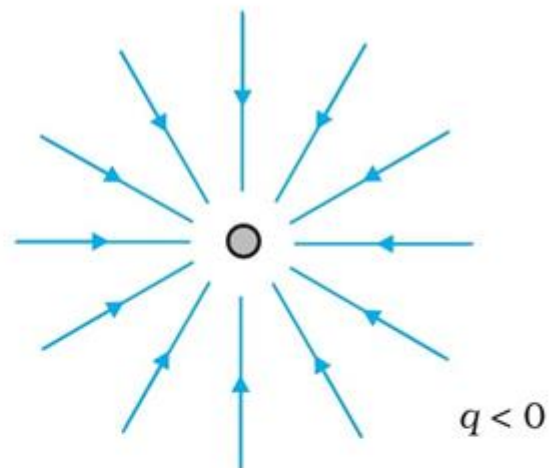

(b)

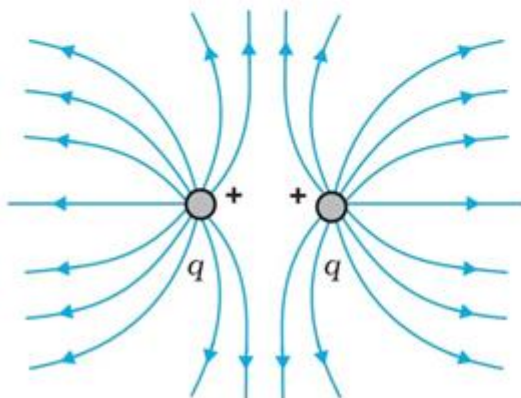

(c)

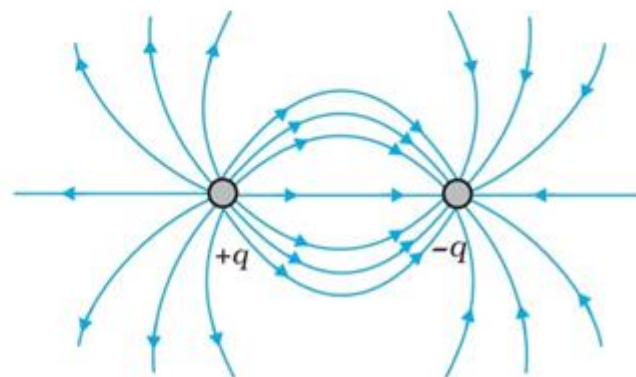

(d)

Electric Dipole:

A configuration of two charges of same magnitude q , but of opposite sign, separated by a small distance (say $2a$) is called an electric dipole.

Dipole moment for an electric dipole is a vector quantity directed from the negative charge to the positive charge and its magnitude is $p = q \times 2a$ (charge \times separation). The SI unit of dipole moment is $C\text{-m}$ (coulombmeter).

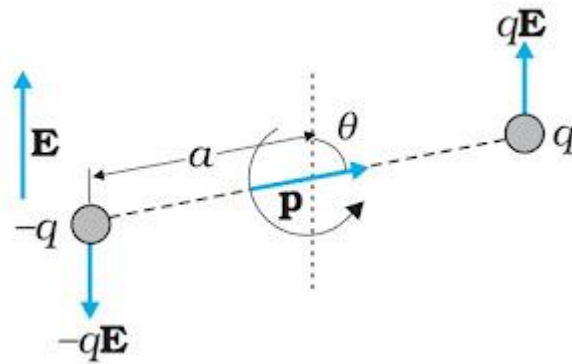

Gauss's Law:

- The flux of electric field through any closed surface S is $1/\epsilon_0$ times the
- Total charge enclosed by S .
- Electric field outside the charged shell is as though the total charge is concentrated at the center. The same result is true for a solid sphere of uniform volume charge density.
- The electric field is zero at all points inside a charged shell.

Deduction of Coulomb's law from Gauss' Law:

Consider a charge $+q$ in place at origin in a vacuum. We want to calculate the electric field due to this charge at a distance r from the charge. Imagine that the charge is surrounded by an imaginary sphere of radius r as shown in the figure below. This sphere is called the Gaussian sphere.

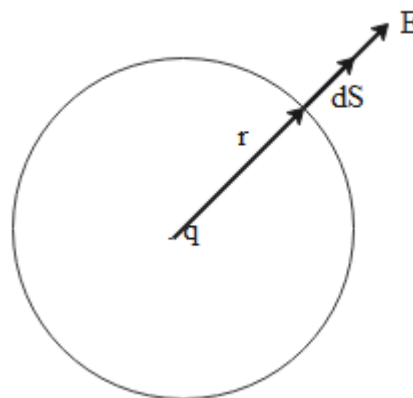

Consider a small area element dS on the Gaussian sphere. We can calculate the flux through this area element due to charge as follows:

$$\oint \vec{E} \cdot \vec{ds} = E \oint ds$$

$$\oint \vec{E} \cdot \vec{ds} = E(4\pi r^2)$$

Using this in Gauss theorem we get

$$E(4\pi r^2) = \frac{q}{\epsilon_0}$$

$$E = \frac{1}{4\pi\epsilon_0} \frac{q}{r^2}$$

We know that

$$F = Eq_0$$

$$F = \frac{1}{4\pi\epsilon_0} \frac{qq_0}{r^2}$$

This is the required Coulomb's law obtained from Gauss theorem.

Dipole Placed in Uniform External Field:

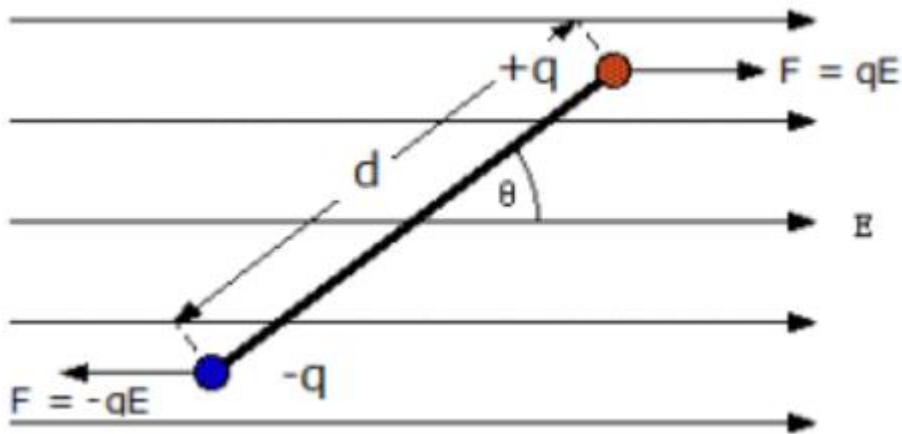

Since the impact of an external electric field on charges is already known to us; a dipole too will experience some form of force when introduced to an external field. It is interesting to learn that, a dipole placed in an external electric field acquires a rotating effect. This rotating effect is termed as 'torque' felt by the dipole. Excitingly, the net torque can be calculated on the opposite charges present in a dipole for estimating the overall rotation.

Torque on dipole:

Consider a dipole located in the same position 'E' to calculate the torque received by the dipole when positioned outside. The compulsory charge will be placed below the 'qE' magnitude as you go up, while the negative charge will be placed below the 'qE' magnitude as you go down.

Since the absolute power is zero, it can be seen that the dipole is in the equation at the moment. But what is the rotation rate? In this case, the dipole may remain stable but rotates at a certain angular velocity. This fact has been demonstrated by

experimentation, and it shows that both electrostatic forces (qE) act as clock-related torque.

As a result, when a dipole is inserted into the same external electrical circuit, it rotates. Torque always works with external force applied which will be in pairs. Moreover, its size is a result of its strength and arm. The arm can be thought of as the distance between the point of force applied and the point at which rotation occurs at the dipole.

Torque

Torque (τ) = Force \times distance separating forces

Torque is a vector whose direction is determined by the force acting on the axis. The magnitude of the torque vector is determined as follows:

$$T = F r \sin\theta$$

Which means,

F - force acting on the axis

r - temporary arm length

θ - angle between force vector and temporary arm

τ - is the vector of torque

Derivation of Torque

Consider a dipole with the angles of $+q$ and q forming a dipole because they are separated by a distance of d . Positioned in the same electric field of power E , the dipole axis forms an θ angle with an electric field.

Charging power, $F = \pm q E$

Elements of power perpendicular to dipole, $F = \pm q E \sin\theta$

Since ' qd ' is the magnitude of the dipole moment (p), and the direction of the dipole moment ranges from positive to negative; torque is the product of a dipole moment cross and an electric field. When the direction of the electric field is positive, the torque is in the clock (therefore negative) in the image above.

So,

$$\tau = - pE\sin\theta$$

An incorrect sign indicates that the torque is in the clockwise direction.

Potential energy of dipole:

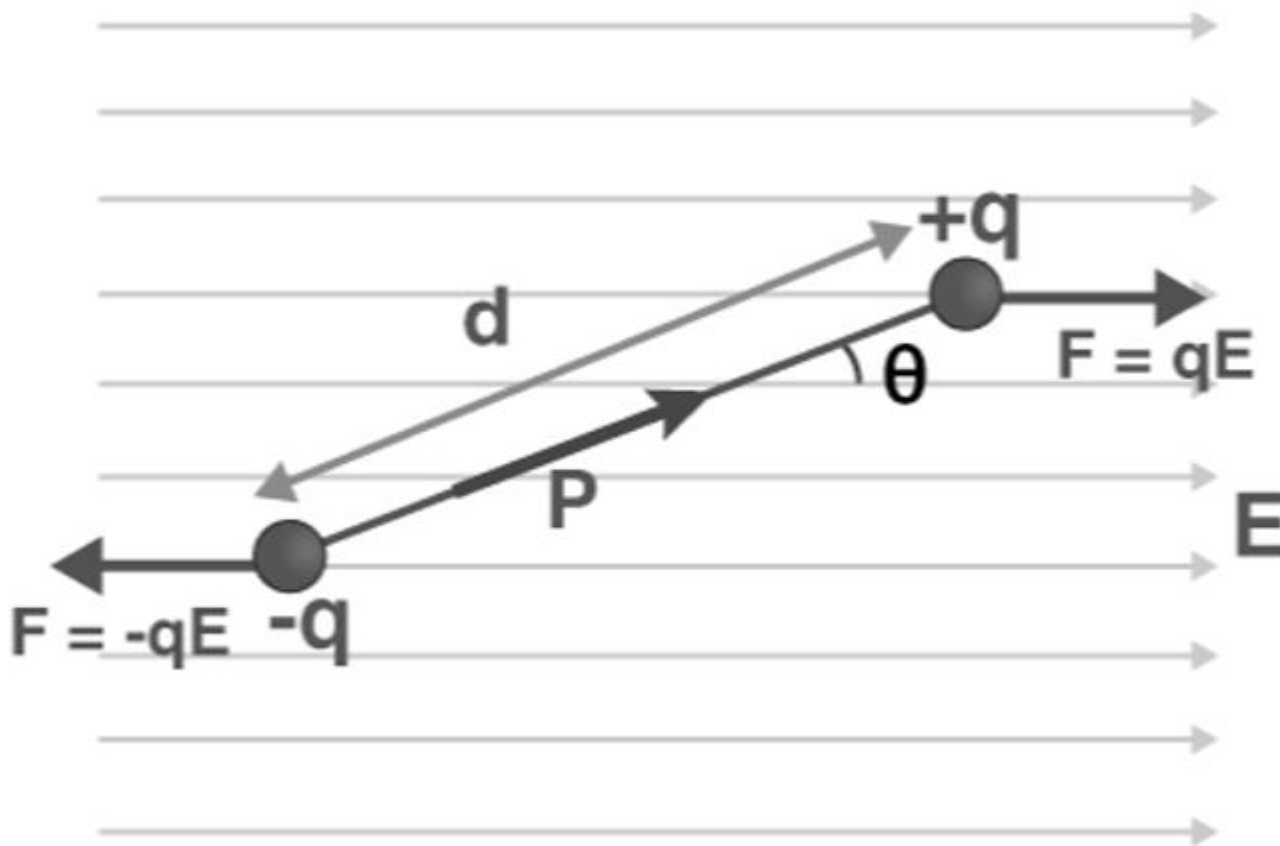

Consider a dipole with charges $q_1 = +q$ and $q_2 = -q$ placed in a uniform electric field as shown in the figure above. The charges are separated by a distance d and the magnitude of an electric field is E . The force experienced by the charges is given as $-qE$ and $+qE$, as can be seen in the figure.

As we know that, when a dipole is placed in a uniform electric field, both the charges as a whole do not experience any force, but it experiences a torque equal to τ which can be given as,

$$\tau = \mathbf{p} \times \mathbf{E}$$

Consider a dipole with charges $q_1 = +q$ and $q_2 = -q$ placed in a uniform electric field as shown in the figure above. The charges are separated by a distance d and the magnitude of an electric field is E . The force experienced by the charges is given as $-qE$ and $+qE$, as can be seen in the figure.

As we know that, when a dipole is placed in a uniform electric field, both the charges

as a whole do not experience any force, but it experiences a torque equal to τ which can be given as,

$$= pE(\cos\theta_0 - \cos\theta_1)$$

As we know that the work done in bringing a system of charges from infinity to the given configuration is defined as the potential energy of the system, hence the potential energy $U(\theta)$ can be associated with the inclination θ of the dipole using the above relation.

$$U(\theta) = pE(\cos\theta_0 - \cos\theta_1)$$

From the above equation, we can see that the potential energy of dipole placed in an external field is zero when the angle θ is equal to 90° or when the dipole makes an angle of 90° .

Considering the initial angle to be the angle at which the potential energy is zero, the potential energy of the system can be given as,

$$U(\theta) = pE(\cos\frac{\pi}{2} - \cos\theta) = -pE \cos\theta = -p \cdot E$$

Workdone by dipole:

A pair of force which is equal in magnitude, with opposite direction, and displaced by perpendicular distance or moment is known as the couple.

When a couple acts on a dipole

$$\tau = PE \sin\theta$$

Work done to rotate a dipole is given by

$$dw = \tau d\theta$$

=

$$PE \sin\theta d\theta$$

Total work done is given by

$$W = \int dw = \int PE \sin\theta d\theta$$

When the dipole is rotated from 0 to θ degrees, work done is given by

$$W = PE \int_0^\Theta \sin\Theta d\Theta$$

$$W = PE[-\cos\Theta]^\Theta$$

$$W = PE[-\cos\Theta + \cos 0]$$

Since $\cos 0 = 1$

Hence, the work done to rotate a dipole in an external electric uniform field is

$$W = PE[1 - \cos\Theta]$$

Work done if dipole rotated from 90 degree

$$\Theta = 90^\circ$$

$$W = PE \left[1 - \frac{\cos}{90} \right]$$

Since $\cos 90 = 0$

$$W = PE$$

Work done if dipole rotated from 180 degree

When

$$\Theta = 180^\circ$$

$$W = PE \left[1 - \frac{\cos}{180} \right]$$

$$W = PE[1 + 1]$$

$$W = 2PE$$

The dipole is said to be stable when the dipole is aligned in the direction of the electric field.

Stable and unstable equilibrium:

Stable equilibrium

“A body is said to be in stable equilibrium if after a slight tilt it returns to its previous position.” stable equilibrium state

Consider a book lying on the table. Tilt the book slightly about its one edge by lifting it from the opposite side. It returns to its previous position when sets free. Such a state of the body is called a stable equilibrium.

When a body is in stable equilibrium, its center of gravity is at the lowest position. When it is tilted, its center of gravity rises. It returns to its stable equilibrium as long as the center of gravity acts through the base of the body.

Examples of stable equilibrium:

- Chair lying on the floor
- The heavy base of the vehicle
- Table lying on the ground
- Cone lying on its base by lowering its center of gravity
- Bottle lying on its base

Unstable equilibrium:

“If a body does not return to its previous position when sets free after the slightest tilt is said to be in unstable equilibrium.”unstable equilibrium state

Take a pencil and try to keep it in the vertical position on its tip. Whenever you leave it, the pencil topples over about its tip and falls down. This is called an unstable equilibrium. In an unstable equilibrium, a body may be made to stay only for a moment. Thus a body is an unstable equilibrium.

The center of gravity of the body is at its highest position in the state of unstable equilibrium. As the body topples over about its base (tip), its center of gravity moves towards its lower position and does not return to its previous position.

Example of unstable equilibrium:

- When the ice cream cone is made to rest on its apex on a book, the movement of the book will disturb the position of the ice cream cone. This is an example of unstable equilibrium.
- When the weather changes from freezing to hot to freezing rapidly and without reason, this is an example of a time when it is unstable. When a person has a bad temper that can explode or flare up with no provocation at all, this is an example of a person who would be described as unstable. Not firmly placed; unsteady.

Electric Field on axial and equatorial line

Axial line: Axial line is the line which is passing through the positive and negative charges and the point lies on that line is called the axial point.

Electric field on axial line of dipole is given by:

$$\vec{E}_{ax} = \frac{2\vec{p}}{4\pi\epsilon_0 r^3} \text{ for } r \gg a$$

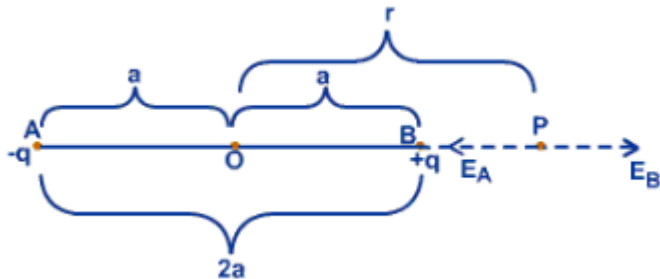

Equatorial line: Equatorial line is the perpendicular line to the line passing through the positive and negative charges and the point lies on that line is known as the equatorial point.

Electric field on equatorial line of dipole is given by:

$$\vec{E}_{ax} = -\frac{\vec{p}}{4\pi\epsilon_0 r^3} \text{ for } r \gg a$$

$$\Rightarrow \vec{E}_{ax} = -2\vec{E}_{eq}$$

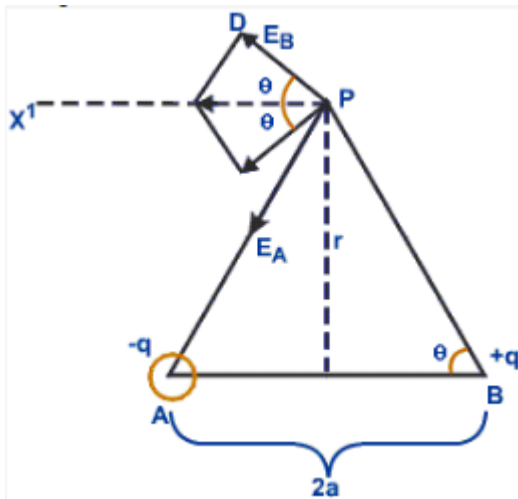

Relation between electric field at axial and equatorial line

Electric field due to an electric dipole at points situated at a distance r along its axial line is given as,

$$E_{\text{equ.}} = \frac{2p}{4\pi \epsilon_0 r^3} \dots (i)$$

Electric field due to an electric dipole at points situated at a distance r along its equatorial plane is given as,

$$E_{\text{equ.}} = \frac{p}{4\pi \epsilon_0 r^3} \dots (ii)$$

From (i) and (ii)

$$\frac{E_{\text{axial}}}{E_{\text{equ.}}} = 2$$

Therefore, ratio is 2 : 1

Relation between E and V:

The electric field exists if and only if there is a electric potential difference. If the charge is uniform at all points, however high the electric potential is, there will not be any electric field. Thus, the relation between electric field and electric potential can be generally expressed as – “Electric field is the negative space derivative of electric potential.”

Electric Field And Electric Potential

The relation between Electric field and electric potential is mathematically given by-

$$E = - \frac{dV}{dx}$$

Where,

E is the Electric field.

V is the electric potential.

dx is the path length.

– Sign is the electric gradient

Direction of Electric Field

If the field is directed from lower potential to higher then the direction is taken to be positive.

If the field is directed from higher potential to lower potential then the direction is taken as negative.

Test charge	Formula	Electric gradient
Positive	$\frac{w}{q_0} = \int_a^b \vec{E} \cdot d\vec{l} = V_b - V_a$	Higher as you go closer towards test charge.
Negative	$\frac{w}{q_0} = \int_a^b \vec{E} \cdot d\vec{l} = V_a - V_b$	Higher as you go move away from test charge.

Equipotential surface	$\frac{w}{q_0} = \int_a^b \vec{E} \cdot d\vec{l} = 0$	Electric potential is perpendicular to Electric field lines.
-----------------------	---	--

Electric Field And Electric Potential Relation Derivation:

$$W(q_0) = \int_a^b \vec{F} \cdot d\vec{l} = q_0 \int_a^b \vec{E} \cdot d\vec{l}$$

Where,

- F is the force applied
- dl is the short element of the path while moving it from a to b.

The force can be written as charge times electric field.

$$= q_0 \int_a^b \vec{E} \cdot d\vec{l}$$

Dividing both sides by test charge q_0

$$\frac{w}{q_0} = \int_a^b \vec{E} \cdot d\vec{l}$$

Workdone by the test charge is the potential $V_a - V_b$

$$\int_a^b \vec{E} \cdot d\vec{l} = V_a - V_b$$

For equipotential surface, $V_a = V_b$ thus,

$$\int_a^b \vec{E} \cdot d\vec{l} = 0$$

Class : 12th Physics
Chapter- 1 : Electric Charges and Fields

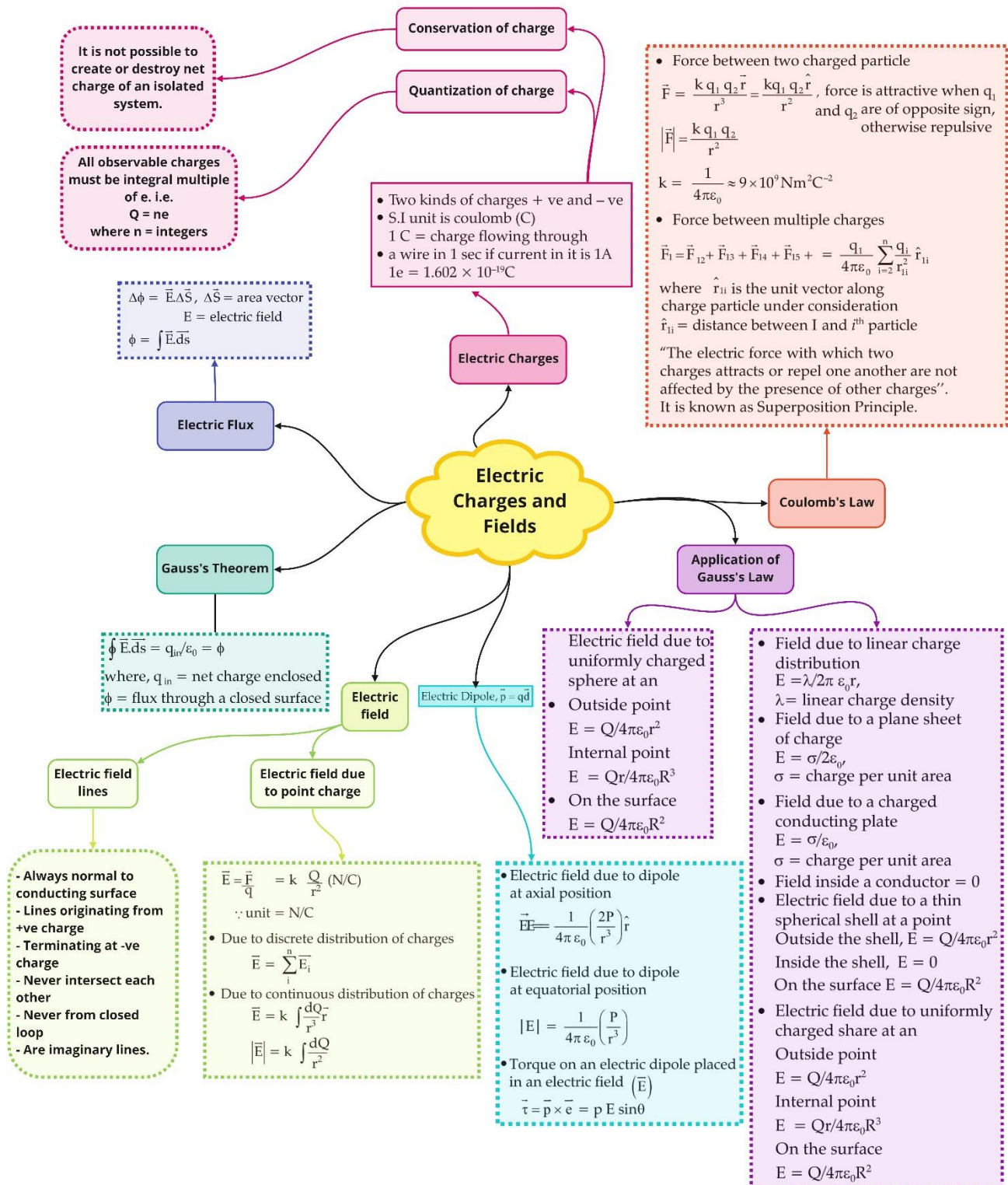

Important Questions

Multiple Choice questions-

1. The surface considered for Gauss's law is called

- (a) Closed surface
- (b) Spherical surface
- (c) Gaussian surface
- (d) Plane surface

2. The total flux through the faces of the cube with side of length a if a charge q is placed at corner A of the cube is

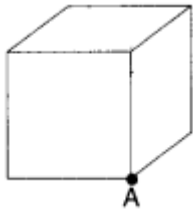

- | | |
|-----------------------------|-----------------------------|
| (a) $\frac{q}{8\epsilon_0}$ | (b) $\frac{q}{4\epsilon_0}$ |
| (c) $\frac{q}{2\epsilon_0}$ | (d) $\frac{q}{\epsilon_0}$ |

3. Which of the following statements is not true about Gauss's law?

- (a) Gauss's law is true for any closed surface.
- (b) The term q on the right side of Gauss's law includes the sum of all charges enclosed by the surface.
- (c) Gauss's law is not much useful in calculating electrostatic field when the system has some symmetry.
- (d) Gauss's law is based on the inverse square dependence on distance contained in the coulomb's law

4. A charge Q is placed at the center of the line joining two point charges $+q$ and $+q$ as shown in the figure. The ratio of charges Q and q is

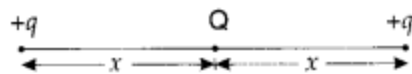

- (a) 4
- (b) 1/4
- (c) -4
- (d) -1/4

5. The force per unit charge is known as

- (a) electric flux
- (b) electric field
- (c) electric potential
- (d) electric current

6. Electric field lines provide information about

- (a) field strength
- (b) direction
- (c) nature of charge
- (d) all of these

7. Which of the following figures represent the electric field lines due to a single negative charge?

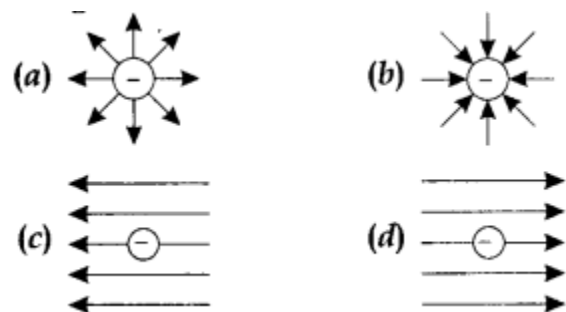

8. The SI unit of electric flux is

- (a) $\text{N C}^{-1} \text{m}^{-2}$
- (b) N C m^{-2}
- (c) $\text{N C}^{-2} \text{m}^2$
- (d) $\text{N C}^{-1} \text{m}^2$

9. The unit of electric dipole moment is

- (a) newton
- (b) coulomb
- (c) farad
- (d) Debye

10. Consider a region inside which, there are various types of charges but the total charge is zero. At points outside the region

- (a) the electric field is necessarily zero.
- (b) the electric field is due to the dipole moment of the charge distribution only.

- (c) the dominant electric field is inversely proportional to r^3 , for large r (distance from origin).
- (d) the work done to move a charged particle along a closed path, away from the region will not be zero.

Very Short:

1. What is the value of the angle between the vectors \vec{P} and \vec{E} for which the potential energy of an electric dipole of dipole moment \vec{P} , kept in an external electric field \vec{E} , has maximum value.
2. Define electric field intensity at a point.
3. Two equal point charges separated by 1 m distance experience force of 8 N. What will be the force experienced by them, if they are held in water, at the same distance? (Given: $K_{\text{water}} = 80$) (CBSE AI 2011C)
4. A charge 'q' is placed at the centre of a cube of side l . What is the electric flux passing through each face of the cube? (CBSE AI 2012) (CBSE Sample Paper 2019)
5. Why do the electric field lines not form closed loops? (CBSE AI 2012C)
6. Two equal balls having equal positive charge 'q' coulomb are suspended by two insulating strings of equal length. What would be the effect on the force when a plastic sheet is inserted between the two? (CBSE AI 2014)
7. What is the electric flux through a cube of side l cm which encloses an electric dipole? (CBSE Delhi 2015)
8. Why are electric field lines perpendicular at a point on an equipotential surface of a conductor? (CBSE AI 2015C)
9. What is the amount of work done in moving a point charge Q , around a circular arc of radius 'r' at the centre of which another point charge 'q' is located? (CBSE AI 2016)
10. How does the electric flux due to a point charge enclosed by a spherical Gaussian surface get affected when its radius is increased? (CBSE Delhi 2016)

Short Questions:

1.
 - (a) Electric field inside a conductor is zero. Explain.
 - (b) The electric field due to a point charge at any point near it is given as

$$\mathbf{E} = \lim_{q \rightarrow 0} \frac{\mathbf{F}}{q}$$

what is the physical significance of this limit?

2. Define the electric line of force and give its two important properties.
3. Draw electric field lines due to (i) two similar charges, (ii) two opposite charges, separated by a small distance.
4. An electric dipole is free to move in a uniform electric field. Explain what is the force and torque acting on it when it is placed
 - (i) parallel to the field
 - (ii) perpendicular to the field
5. A small metal sphere carrying charge +Q. is located at the centre of a spherical cavity in a large uncharged metallic spherical shell. Write the charges on the inner and outer surfaces of the shell. Write the expression for the electric field at the point P₁ (CBSE Delhi 2014C)
6. Two-point charges q and -2q are kept 'd' distance apart. Find the location of the point relative to charge 'q' at which potential due to this system of charges is zero. (CBSE AI 2014C)
7. Two small identical electrical dipoles AB and CD, each of dipole moment 'p' are kept at an angle of 120° as shown in the figure. What is the resultant dipole moment of this combination? If this system is subjected to the electric field (\vec{E}) directed along +X direction, what will be the magnitude and direction of the torque acting on this? (CBSE Delhi 2011)
8. A metallic spherical shell has an inner radius R₁ and outer radius R₂. A charge Q is placed at the centre of the spherical cavity. What will be surface charge density on (i) the inner surface, and (ii) the outer surface? (NCERT Exemplar)

Long Questions:

1.
 - (a) State Gauss theorem in electrostatics. Using it, prove that the electric field at a point due to a uniformly charged infinite plane sheet is independent of the distance from it.
 - (b) How is the field directed if (i) the sheet is positively charged, (ii) negatively charged? (CBSE Delhi 2012)
2. Use Gauss's law to derive the expression for the electric field (\vec{E}) due to a straight uniformly charged infinite line of charge $\lambda \text{ Cm}^{-1}$. (CBSE Delhi 2018)

Assertion and Reason Questions-

1. For two statements are given-one labelled Assertion (A) and the other labelled Reason (R). Select the correct answer to these questions from the codes (a), (b), (c) and (d) as given below.

- Both A and R are true, and R is the correct explanation of A.
- Both A and R are true, but R is not the correct explanation of A.
- A is true but R is false.
- A is false and R is also false.

Assertion (A): The electric flux emanating out and entering a closed surface are 8×10^3 and $2 \times 10^3 \text{Vm}$ respectively. The charge enclosed by the surface is $0.053 \mu\text{C}$.

Reason (R): Gauss's theorem in electrostatics may be applied to verify.

2. For two statements are given-one labelled Assertion (A) and the other labelled Reason (R). Select the correct answer to these questions from the codes (a), (b), (c) and (d) as given below.

- Both A and R are true, and R is the correct explanation of A.
- Both A and R are true, but R is not the correct explanation of A.
- A is true but R is false.
- A is false and R is also false.

Assertion (A): Charge is quantized.

Reason (R): Charge which is less than 1 C is not possible.

Case Study Questions-

1. Electric field strength is proportional to the density of lines of force i.e., electric field strength at a point is proportional to the number of lines of force cutting a unit area element placed normal to the field at that point. As illustrated in the given figure, the electric field at P is stronger than at Q.

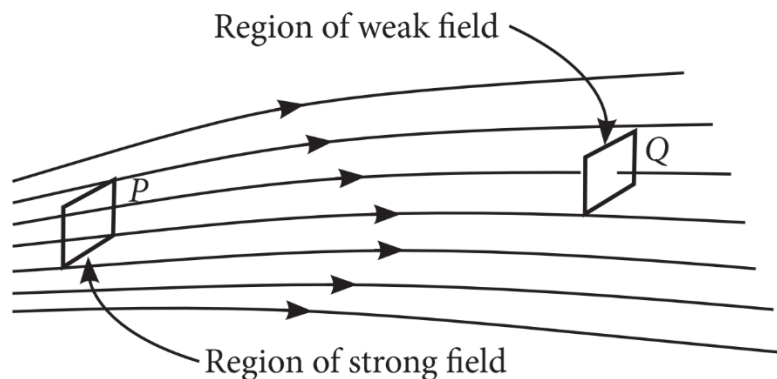

- Electric lines of force about a positive point charge are:
 - Radially outwards.

- b) Circular clockwise.
 - c) Radially inwards.
 - d) Parallel straight lines.
- (ii) Which of the following is false for electric lines of force?
- a) They always start from positive charges and terminate on negative charges.
 - b) They are always perpendicular to the surface of a charged conductor.
 - c) They always form closed loops.
 - d) They are parallel and equally spaced in a region of uniform electric field.
- (iii) Which one of the following pattern of electric line of force is not possible in field due to stationary charges?

a)

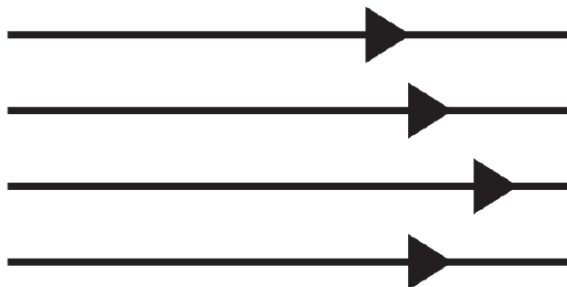

b)

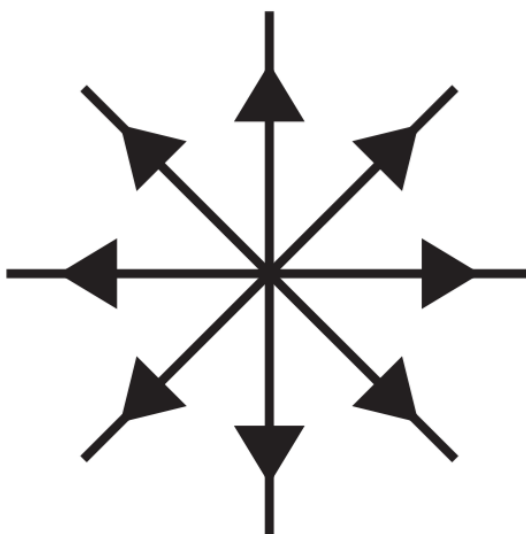

c)

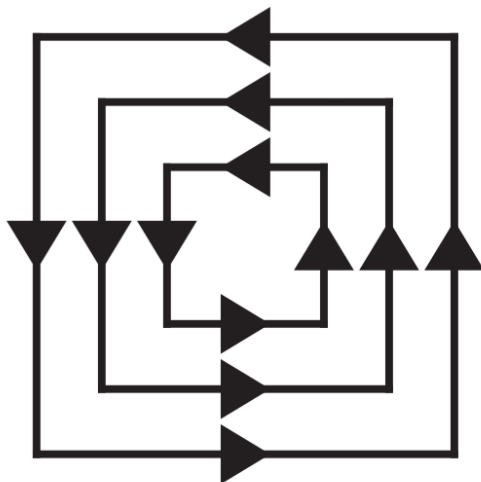

d)

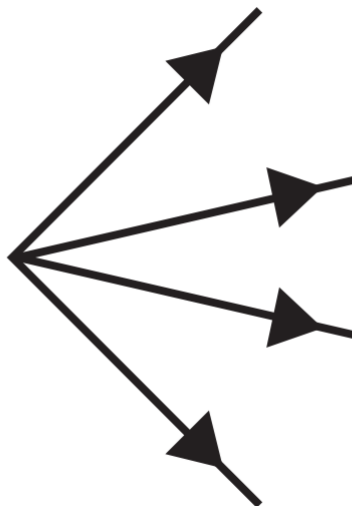

(iv) Electric lines of force are curved:

- a) In the field of a single positive or negative charge.
- b) In the field of two equal and opposite charges.
- c) In the field of two like charges.
- d) Both (b) and (c).

(v) The figure below shows the electric field lines due to two positive charges. The magnitudes E_A , E_B and E_C of the electric fields at points A, B and C respectively are related as:

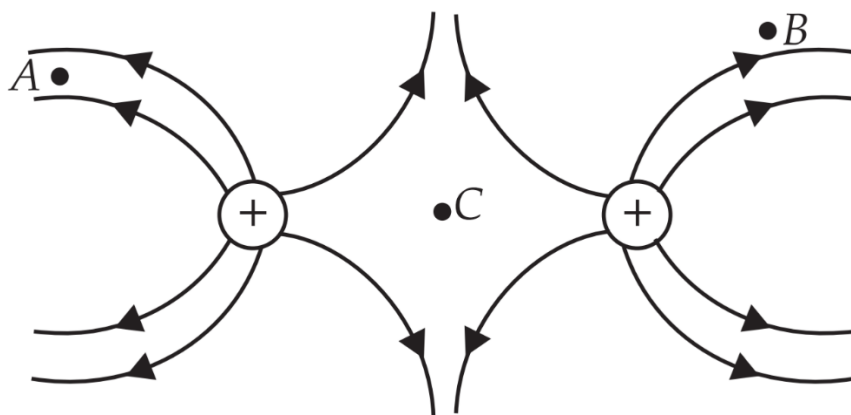

- a) $E_A > E_B > E_C$
- b) $E_B > E_A > E_C$
- c) $E_A = E_B > E_C$
- d) $E_A > E_B = E_C$

2. Net electric flux through a cube is the sum of fluxes through its six faces. Consider a cube as shown in figure, having sides of length $L = 10.0\text{cm}$. The electric field is uniform, has a magnitude $E = 4.00 \times 10^3\text{N C}^{-1}$ and is parallel to the xy plane at an angle of 37° measured from the $+x$ - axis towards the $+y$ - axis.

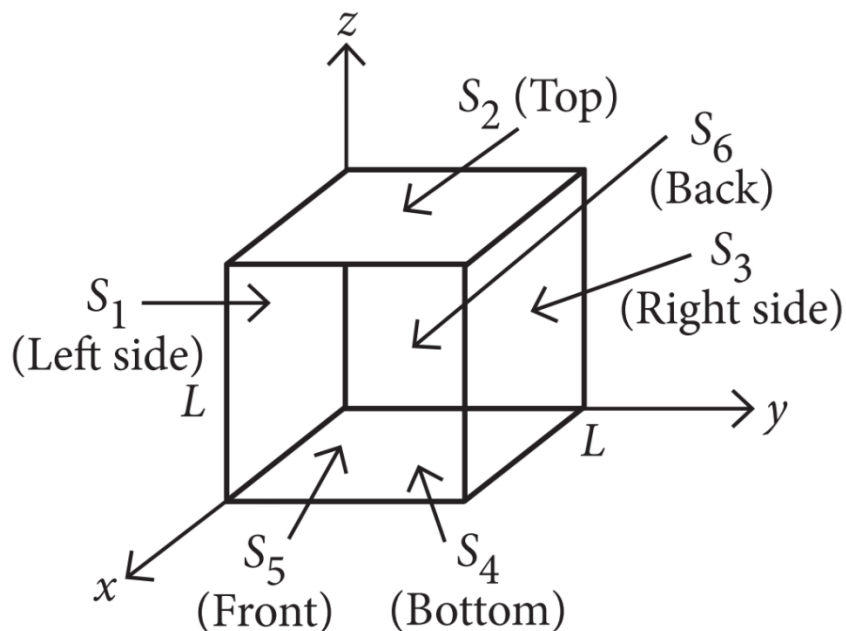

(i) Electric flux passing through surface S_6 is:

- a) $-24\text{N m}^2\text{C}^{-1}$
- b) $24\text{N m}^2\text{C}^{-1}$
- c) $32\text{N m}^2\text{C}^{-1}$
- d) $-32\text{N m}^2\text{C}^{-1}$

(ii) Electric flux passing through surface S_1 is:

- a) $-24\text{N m}^2\text{ C}^{-1}$
 - b) $24\text{N m}^2\text{ C}^{-1}$
 - c) $32\text{N m}^2\text{ C}^{-1}$
 - d) $-32\text{N m}^2\text{ C}^{-1}$
- (iii) The surfaces that have zero flux are:
- a) S_1 and S_3
 - b) S_5 and S_6
 - c) S_2 and S_4
 - d) S_1 and S_2
- (iv) The total net electric flux through all faces of the cube is:
- a) $8\text{N m}^2\text{ C}^{-1}$
 - b) $-8\text{N m}^2\text{ C}^{-1}$
 - c) $24\text{N m}^2\text{ C}^{-1}$
 - d) Zero.
- (v) The dimensional formula of surface integral $\oint \vec{E} \cdot d\vec{S}$ of an electric field is:
- a) $[\text{M L}^2\text{T}^{-2}\text{ A}^{-1}]$
 - b) $[\text{M L}^3\text{T}^{-3}\text{ A}^{-1}]$
 - c) $[\text{M L}^{-1}\text{T}^3\text{ A}^{-3}]$
 - d) $[\text{M L}^{-3}\text{T}^{-3}\text{ A}^{-1}]$

✓ Answer Key:

Multiple Choice Answers-

1. Answer: c
2. Answer: a
3. Answer: c
4. Answer: d
5. Answer: b
6. Answer: d
7. Answer: b
8. Answer: d
9. Answer: d

10. Answer: c

Very Short Answers:

1. Answer:

$$\text{P.E.} = -pE \cos \theta$$

P.E. is maximum when $\cos \theta = -1$, i.e.

$$\theta = 180^\circ$$

2. Answer: Electric field intensity at a point is defined as the force experienced by a unit test charge placed at that point. Mathematically

we have

$$\vec{E} = \lim_{\delta q \rightarrow 0} \frac{\vec{F}}{\delta q}$$

3. Answer: The force in water is given by

$$F_w = \frac{F_{\text{air}}}{K} = \frac{8}{80} = 0.1 \text{ N}$$

4. Answer: $\Phi = q/6\epsilon_0$

5. Answer: It is due to the conservative nature of the electric field.

6. Answer: It decreases because force $\propto \frac{1}{k}$ and $k > 1$.

7. Answer: Zero

8. Answer: So that no net force acts on the charge at the equipotential surface, and it remains stationary.

9. Answer: Zero.

10. Answer: No change, as flux does not depend upon the size of the Gaussian surface.

Short Questions Answers:

1. Answer:

(a) By Gauss theorem $\oint \vec{E} \cdot d\vec{S} = \frac{q}{\epsilon_0}$. Since there is no charge inside a conductor therefore in accordance with the above equation the electric field inside the conductor is zero.

(b) It indicates that the test charge should be infinitesimally small so that it may not disturb the electric field of the source charge.

2. Answer:

It is a line straight or curved, a tangent to which at any point gives the direction of the electric field at that point.

(a) No two field lines can cross, because at the point of intersection two tangents can be drawn giving two directions of the electric field which is not possible.

(b) The field lines are always perpendicular to the surface of a charged conductor.

3. Answer:

(a) The diagram is as shown.

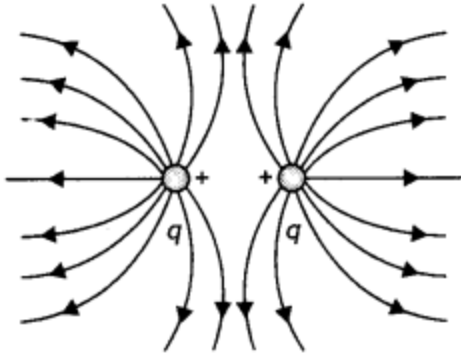

(b) The diagram is as shown.

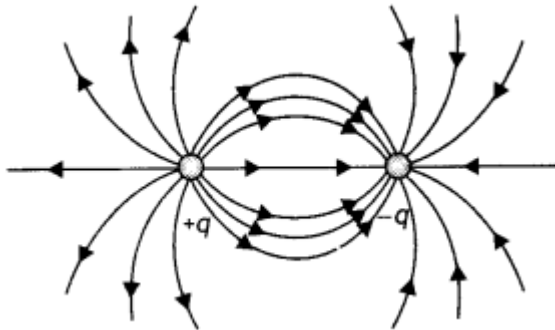

4. Answer:

(i) When an electric dipole is placed parallel to a uniform electric field, net force, as well as net torque acting on the dipole, is zero and, thus, the dipole remains in equilibrium.

(ii) When the dipole is placed perpendicular to the field, two forces acting on the dipole form a couple, and hence a torque acts on it which aligns its dipole along the direction of the electric field.

5. Answer:

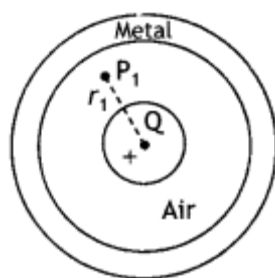

Charge on inner surface $-Q$.

Charge on outer surface $+Q$.

Electric field at point P $= E = k \frac{Q}{r_1^2}$

6. Answer:

Let the potential be zero at point P at a distance x from charge q as shown

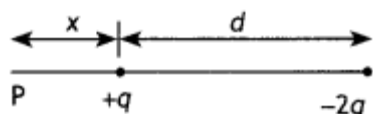

Now potential at point P is

$$V = \frac{kq}{x} + \frac{k(-2q)}{d+x} = 0$$

Solving for x we have

$$x = d$$

7. Answer:

The resultant dipole moment of the combination is

$$P_R = \sqrt{p^2 + p^2 + 2p^2 \cos 120^\circ} = p$$

since $\cos 120^\circ = -1/2$

This will make an angle of 30° with the X-axis, therefore torque acting on it is

$$\tau = PE \sin 30^\circ = pE/2 \text{ (Along Z-direction)}$$

Answer: The induction of charges is as shown.

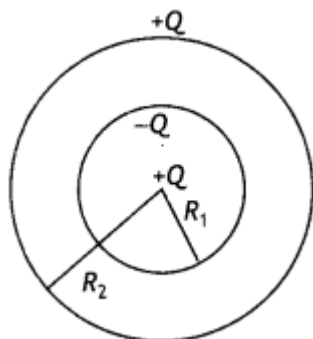

Therefore, surface charge density on the inner and the outer shell is on the outer surface is

$$\sigma_{\text{inner}} = \frac{-Q}{4\pi R_1^2}$$

$$\sigma_{\text{outer}} = \frac{+Q}{4\pi R_2^2}$$

Long Questions Answers:

1. Answer:

It states, "The net electric flux through any Gaussian surface is equal to $\frac{1}{\epsilon_0}$ times the net electric charge enclosed by the surface.

$$\text{Mathematically, } \Phi = \oint \vec{E} \cdot d\vec{A} = \frac{q_{\text{in}}}{\epsilon_0}$$

Consider an infinite plane sheet of charge. Let a be the uniform surface charge density, i.e. the charge per unit surface area. From symmetry, we find that the electric field must be perpendicular to the plane of the sheet and that the direction of E on one side of the plane must be opposite to its direction on the other side as shown in the figure below. In such a case let us choose a Gaussian surface in the form of a cylinder with its axis perpendicular to the sheet of charge, with ends of area A .

The charged sheet passes through the middle of the cylinder's length so that the cylinder's ends are equidistant from the sheet. The electric field has a normal component at each end of the cylinder and no normal component along the curved surface of the cylinder. As a result, the electric flux is linked with only the ends and not the curved surface.

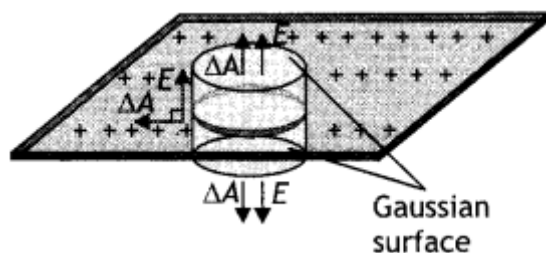

Therefore, by the definition of electric flux, the flux linked with the Gaussian surface is given by

$$\Phi = \oint_A \vec{E} \cdot \vec{\Delta A}$$

$$\Phi = E_A + E_A = 2E_A \dots (1)$$

But by Gauss's Law

$$\Phi = \frac{q}{\epsilon_0} = \frac{\sigma A}{\epsilon_0} [\because q = \sigma A] \dots (2)$$

From equations (1) and (2), we have

$$2E_A = \frac{\sigma A}{\epsilon_0} \dots (3)$$

$$E = \frac{\sigma}{2\epsilon_0} \dots (4)$$

(b)

(i) directed outwards

(ii) directed inwards.

2. Answer:

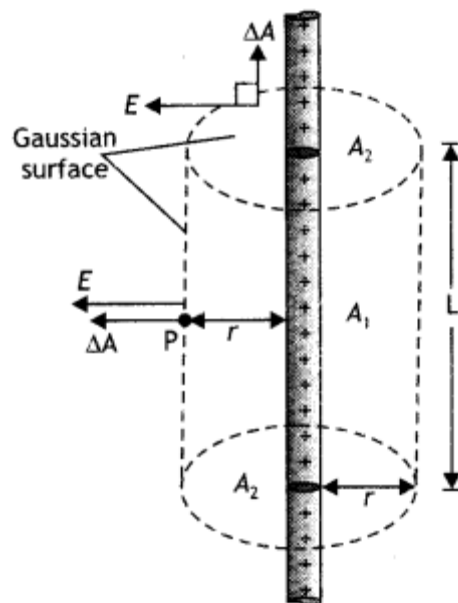

Consider an infinitely Long, thin wire charged positively and having uniform Linear charge density λ . The symmetry of the charge distribution shows that must be perpendicular to the wire and directed outwards. As a result of this symmetry, we consider a Gaussian surface in the form of a cylinder with arbitrary radius r and arbitrary Length L . with its ends perpendicular to the wire as shown in the figure. Applying Gauss's theorem to curved surface ΔA_1 and circular surface ΔA_2 .

$$\Phi = E\Delta A_1 \cos 0^\circ + E\Delta A_2 \cos 90^\circ = \frac{q}{\epsilon_0} = \frac{\lambda l}{\epsilon_0} [\because \lambda = \frac{q}{l}]$$

Or

$$E \cdot 2\pi r l = \frac{\lambda l}{\epsilon_0} \Rightarrow E = \frac{1}{2\pi\epsilon_0} \frac{\lambda}{r}$$

This is the expression for the electric field due to an infinitely long thin wire.

The graph is as shown.

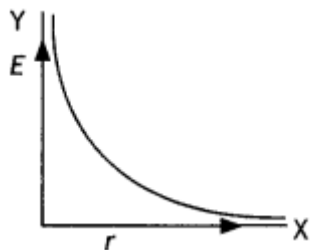

Assertion and Reason Answers-

1. (a) Both A and R are true, and R is the correct explanation of A.

Explanation:

According to Gauss's theorem in electrostatics, $\phi = \frac{q}{\epsilon_0}$

$$\phi = \frac{q}{\epsilon_0} = 8.85 \times 10^{-12} [8 \times 10^3 - 2 \times 10^3]$$

$$= 53.10 \times 10^{-9} \text{C} = 0.053 \mu\text{C}.$$

2. (c) A is true but R is false.

Explanation:

The charge q on a body is given as $q = ne$ where n is any integer positive or negative.

The charge on the electron is $q = 1.6 \times 10^{-19} \text{C}$ which is less than 1C .

Case Study Answers-

1. Answer :

(i) (a) Radially outwards.

(ii) (c) They always form closed loops.

Explanation:

Electric lines of force do not form any closed loops.

(iii) (c)

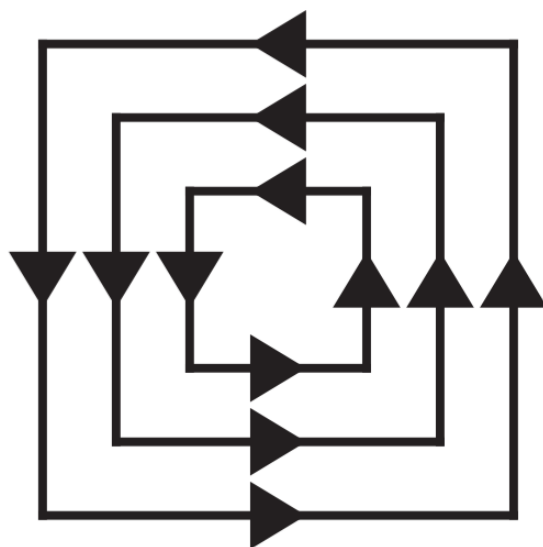
**Explanation:**

Electric field lines can't be closed.

(iv) (d) Both (b) and (c).

(v) (a) $E_A > E_B > E_C$

2. Answer :

i. (d) $-32 \text{ N m}^2 \text{ C}^{-1}$

Explanation:

Electric flux, $\phi = \vec{E} \cdot \vec{A} = EA \cos \theta$.

Where $\vec{A} = \hat{A}n$

For electric flux passing through S_6 , $\hat{n}_{S_6} = -\hat{i}$ (Back)

$$\therefore \phi_{S_6} = -(4 \times 10^3 \text{ N C}^{-1})(0.1\text{m})^2 \cos 37^\circ$$

$$-32 \text{ N m}^2 \text{ C}^{-1}$$

ii. (a) $-24 \text{ N m}^2 \text{ C}^{-1}$

Explanation:

For electric flux passing through S_1 , $\hat{n}_{s_1} = -\hat{j}$ (Left)

$$\therefore \phi_{s_1} = -(4 \times 10^3 \text{ N C}^{-1})(0.1\text{m})^2 \cos(90^\circ - 37^\circ)$$

$$= -24 \text{ N m}^2 \text{ C}^{-1}$$

iii. (c) S_2 and S_4

Explanation:

Here, $\hat{n}_{s_2} = +\hat{k}$ (Top)

$$\therefore \phi_{s_2} = -(4 \times 10^3 \text{ N C}^{-1})(0.1\text{m})^2 \cos 90^\circ = 0$$

$\hat{n}_{s_3} = +\hat{j}$ (Right)

$\hat{n}_{s_4} = -\hat{k}$ (Bottom)

$$\therefore \phi_{s_4} = -(4 \times 10^3 \text{ N C}^{-1})(0.1\text{m})^2 \cos 90^\circ = 0$$

And, $\hat{n}_{s_5} = -\hat{i}$ (Front)

$$\therefore \phi_{s_5} = -(4 \times 10^3 \text{ N C}^{-1})(0.1\text{m})^2 \cos 37^\circ$$

$$= 32 \text{ N m}^2 \text{ C}^{-1}$$

S_2 and S_4 surface have zero flux.

iv. (d) Zero.

Explanation:

As the field is uniform, the total flux through the cube must be zero,

i.e., any flux entering the cube must leave it.

v. (b) $[\text{M L}^3 \text{T}^{-3} \text{A}^{-1}]$

Explanation:

Surface integral $\oint \vec{E} \cdot d\vec{S}$ is the net electric flux over a closed surface S .

$$\therefore [\phi_E] = [\text{M L}^3 \text{T}^{-3} \text{A}^{-1}]$$



C V RAMAN
PUCOLLEGE
INDI

CHAPTER 2: ELECTROSTATIC POTENTIAL AND CAPACITANCE

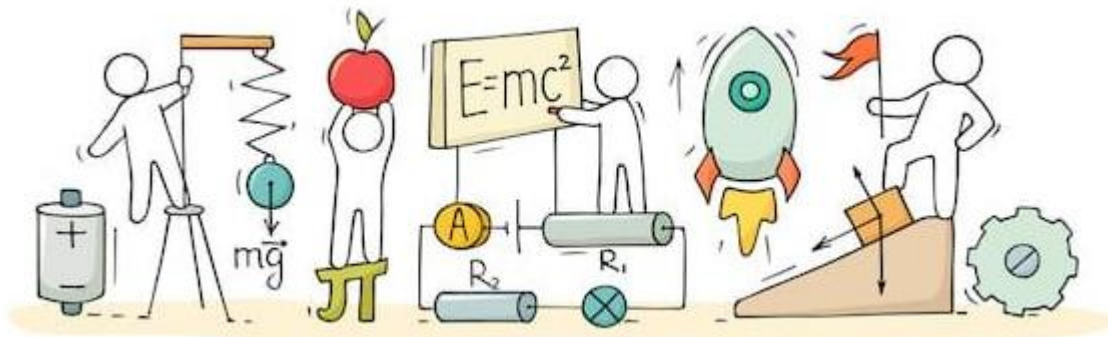

ELECTROSTATIC POTENTIAL AND CAPACITANCE

Introduction:

In the previous chapter, we have learnt about "Electric Charges and Fields". In this chapter, we shall focus Electrostatic Potential and Capacitance. The energy point of view can be used in electricity, and it is especially useful. Energy is also a tool in solving Problems more easily in many cases than by using forces and electric fields.

Electric energy can be stored in a common device called a capacitor, which is found in nearly all electronic circuits. A capacitor is used as a storehouse for energy. Capacitors store the energy in common photo flash units.

Electrostatic Potential:

The electrostatic potential (V) at any point in a region with electrostatic field is the work done in bringing a unit positive charge (without acceleration) from infinity to that point. If 'W' is the work done in moving a charge 'q' from infinity to a point, then the potential at that point is $V = \frac{W}{q}$

Electric Potential Difference:

Similar to electric potential, the electric potential difference is the work done by external force in bringing a unit positive charge from point R to point P. i.e.,

$$V_P - V_R = \frac{U_P - U_R}{q}$$

Here V_P and V_R are the electrostatic potentials at P and R, respectively and U_P and U_R are the potential energies of a charge q when it is at P and at R respectively.

Note: As before, that it is not the actual value of potential but the potential difference that is physically significant. If, as before, we choose the potential to be zero at infinity, the above equation implies.

Unit for Electric Potential:

The unit of measurement for electric potential is the volt, so electric potential is often called voltage. A potential of 1 volt (V) equals 1 joule (J) of energy per 1 coulomb (C) of charge.

$$1V = 1 \frac{J}{C}$$

Conservative Forces:

When one form of energy gets converted to another completely on application or removal of external force, the forces are said to be conservative. Examples of conservative forces are sum of kinetic and potential energies working on a body, spring and gravitational force, coulomb force between two stationary charges, etc.

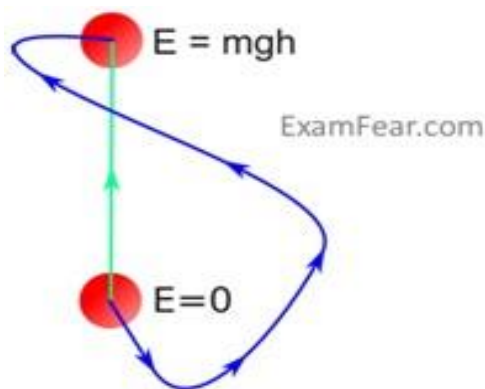

Work done by conservative gravitational force is same for different paths followed by a particle to reach from one point to another.

Work done in moving an object from one point to another depends only on the initial and final positions and is independent of the path taken.

Potential due to a Point Charge:

Consider a point charge q placed at point O . Consider any point P in the field of the above charge. Let us calculate the potential at point P due to the charge q kept a point O . Since work done is independent of path, we choose a convenient path, along the radial direction.

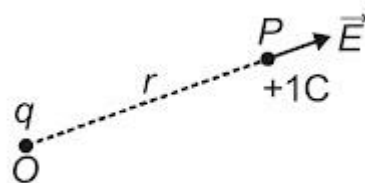

Let the distance $OP = r$.

The electric force at P , due to q will be directed along OP , given by

$$F = \frac{1}{4\pi\epsilon_0} = \frac{qq_0}{r^2}$$

If the work done by moving this positive charge to dr distance is dW then,

$$dW = F (-dr)$$

$$dW = - \int F. dr$$

$$dW = - \int_{\infty}^r F. dr$$

Hence, the total work done in bringing this charge from (∞) to 'r' will be,

$$W = \int_{\infty}^r \frac{1}{4\pi\epsilon_0} \frac{qq_0}{r^2} \cdot dr$$

$$W = - \frac{qq_0}{4\pi\epsilon_0} \int_{\infty}^r \frac{1}{r^2} \cdot dr$$

$$W = - \frac{qq_0}{4\pi\epsilon_0} \left[-\frac{1}{r} \right]_{\infty}^r$$

$$W = \frac{1}{4\pi\epsilon_0} \frac{qq_0}{r^2}$$

Hence, from $V = \frac{W}{q_0}$ electric potential is,

$$V = \frac{1}{4\pi\epsilon_0} \frac{q}{r}$$

This equation is true for any sign of charge q . For $q < 0$, $V < 0$, i.e., work done by the external force per unit positive test charge to bring it from infinity to the point is negative. Also, this equation is consistent with the choice that potential at infinity be zero.

Equipotential Surfaces:

An equipotential surface is a surface with a constant value of potential at all points on the surface. For a single charge q , the potential is given by

$$V = \frac{1}{4\pi\epsilon_0} \frac{q}{r}$$

This shows that V is a constant if r is constant. Thus, equipotential surfaces of a single point charge are concentric spherical surfaces centered at the charge.

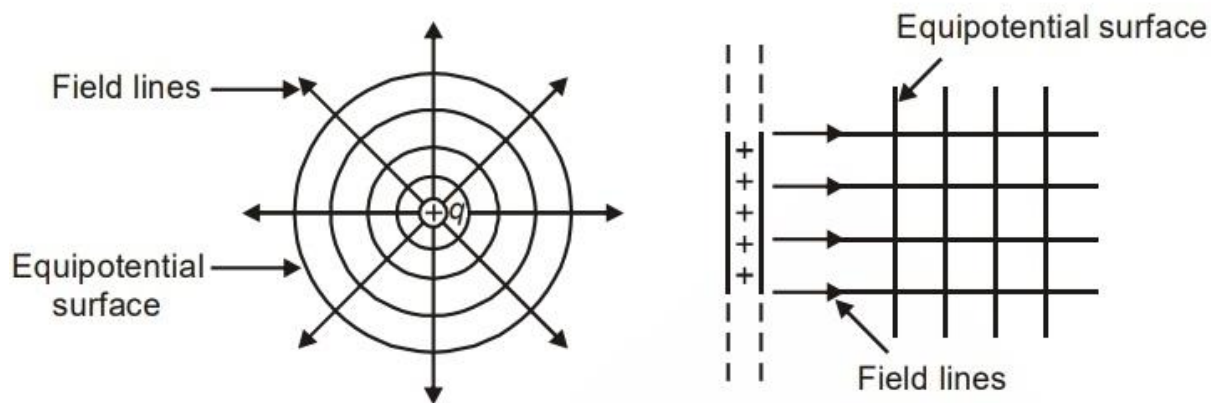
**Example:**

- Surface of a charged conductor.
- All points equidistant from a point charge.

Note:

- An equipotential surface is that at which, every point is at the same potential. As the work done is given by $(V_A - V_B)q_0$.
- Work done by electric field while a charge moves on an equipotential surface is zero as $V_A = V_B$.

Electrostatics of Conductors:

Conductors contain mobile charge carriers. In metallic conductors, these charge carriers are electrons. In a metal, the outer (valence) electrons part away from their atoms and are free to move. These electrons are free within the metal but not free to leave the metal.

Whenever a conductor is placed in an external electric field, the free electrons in it experience a force due to it and start moving opposite to the field. This movement makes one side of conductor positively charged and the other as negatively charged. This creates an electric field in the conductor in a direction opposite to external electric field (called induced field).

Important Points about Electrostatics of Conductors:

- **Inside a conductor, electrostatic field is zero:** In the previous chapter, we have already discussed that “when there is no electric current inside or on the surface of a conductor, the electric field inside the conductor is everywhere zero”.
- **At the surface of a charged conductor, electrostatic field must be normal to the surface at every point:** If the field E is not normal to the surface, it will have a

nonzero component along the surface. Hence the free charge on the surface will move due to electrostatic force on it. But free charge on the surface in electrostatics remains at rest. So, the electrostatic field at the surface of a charged conductor must be normal to the surface.

- **Electrostatic Shielding:** In an electrostatic situation, if a conductor contains a cavity and if no charge is present inside the cavity, then there can be no net charge anywhere on the surface of the cavity. This means that if you are inside a charged conducting box, you can safely touch any point on the inside walls of the box without being electrocuted. This is known as electrostatic shielding.

Dielectrics and Polarization:

Dielectrics are non-conducting substances. In contrast to conductors, they have no (or negligible number of) charge carriers. When a conductor is placed in an external electric field, the free charge carriers move and charge distribution in the conductor adjusts itself in such a way that the electric field due to induced charges opposes the external field within the conductor. This happens until, in the static situation, the two fields cancel each other and the net electrostatic field in the conductor is zero.

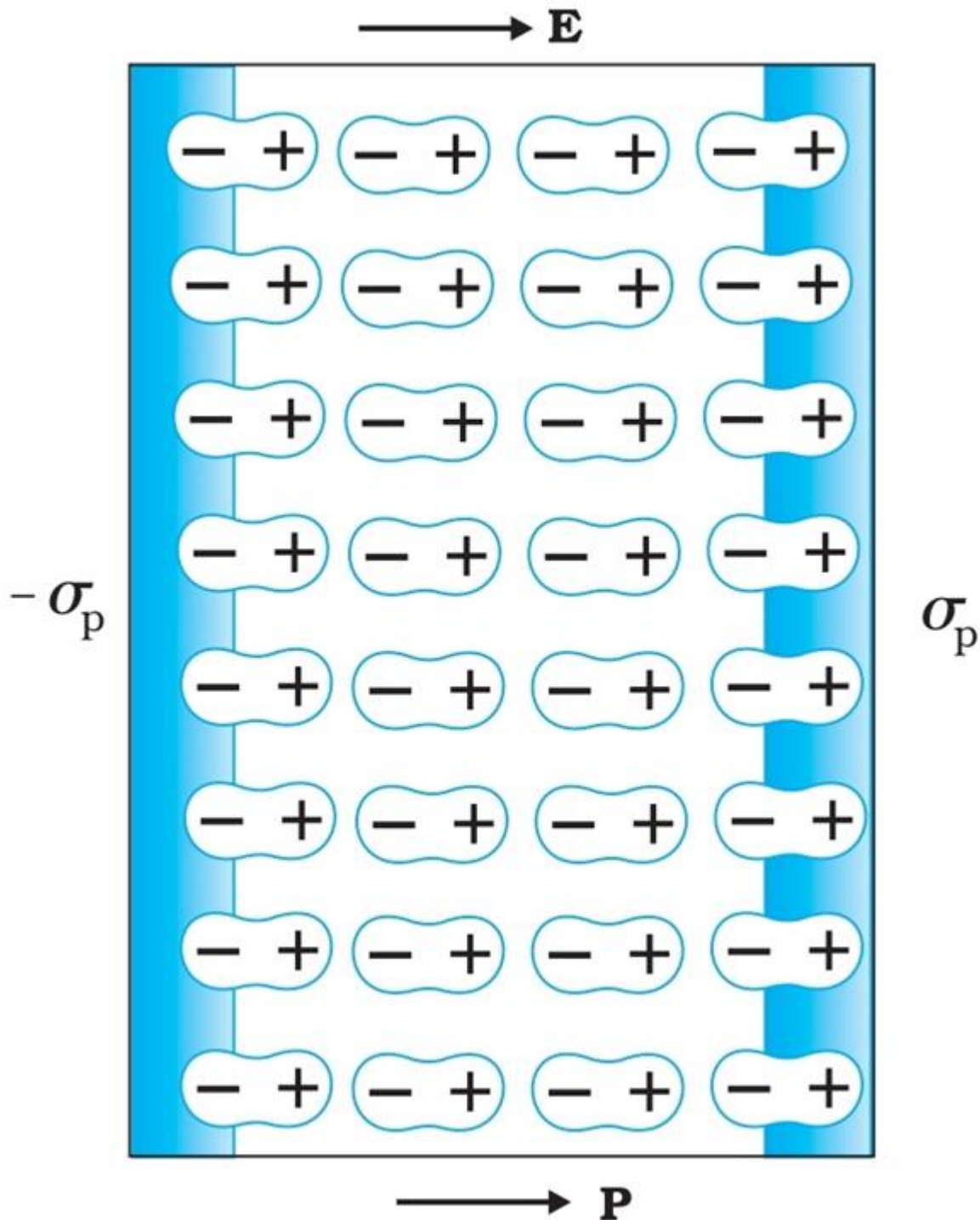

When a dielectric material is kept in an electric field, the external field induces dipole moment by stretching or reorienting molecules of the dielectric. This results in development of net charges on the surface of the dielectric which produce a field that opposes the external field.

In general, the dielectric can be classified into Polar and Non-polar dielectrics. In a non-polar molecule, the centers of positive and negative charges coincide. The molecule thus has no permanent dipole moment. Examples of non-polar molecules are oxygen (O_2) and hydrogen (H_2) molecules which, because of their symmetry, have no dipole

moment. On the other hand, a polar molecule is one in which the centers of positive and negative charges are separated (even when there is no external field). Such molecules have a permanent dipole moment. An ionic molecule such as HCl or a molecule of water (H_2O) are examples of polar molecules.

Behavior of a non-polar dielectric: In an external electric field, the positive and negative charges of a nonpolar molecule are displaced in opposite directions. The displacement stops when the external force on the constituent charges of the molecule is balanced by the restoring force. The non-polar molecule thus develops an induced dipole moment. The dielectric is said to be polarized by the external field.

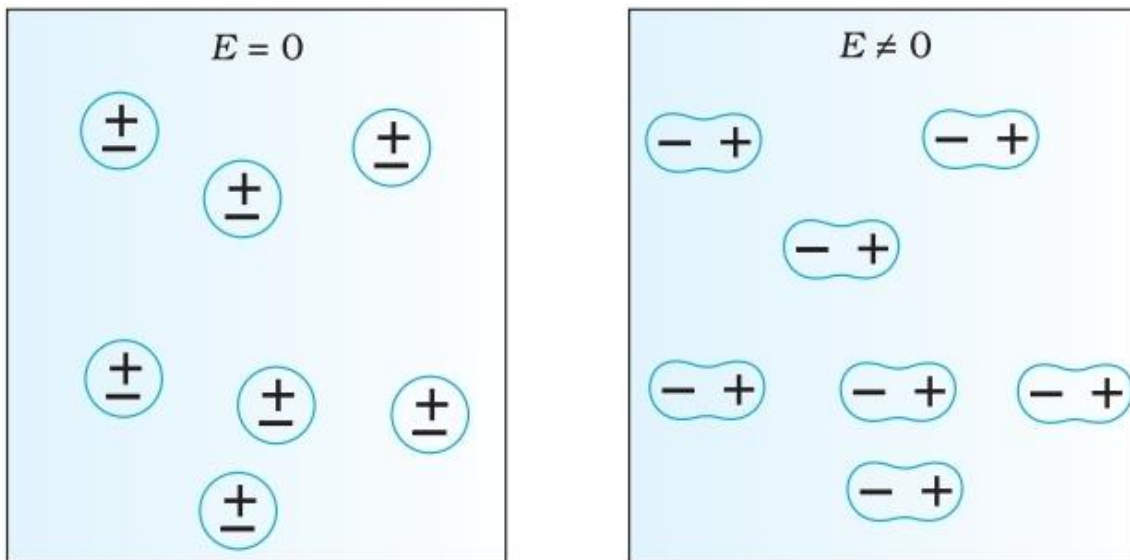

(a) Non-polar molecules

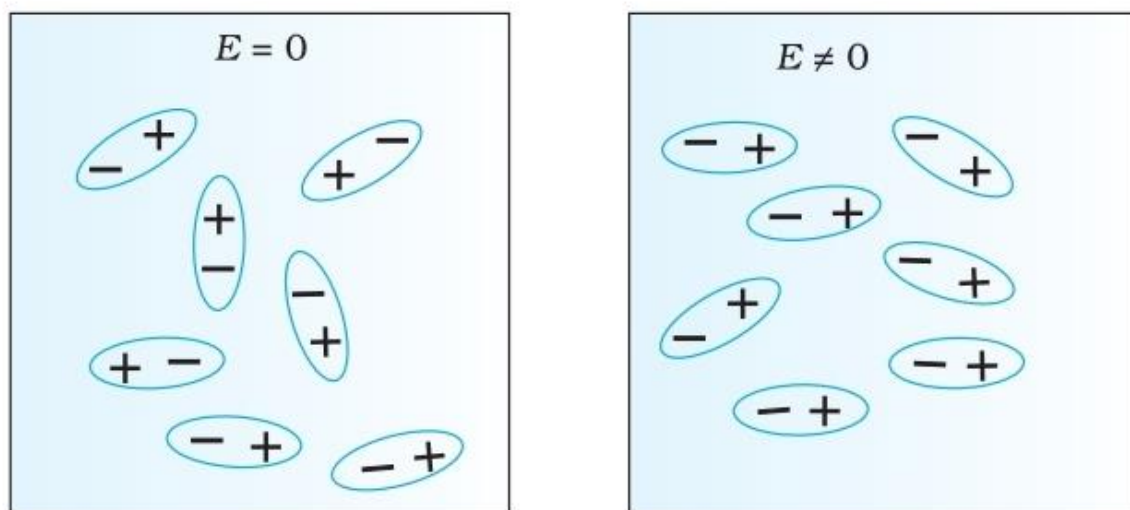

(b) Polar molecules

Behavior of a polar dielectric: A dielectric with polar molecules also develops a net dipole moment in an external field, but for a different reason. In the absence of any

external field, the different permanent dipoles are oriented randomly due to thermal agitation; so, the total dipole moment is zero. When an external field is applied, the individual dipole moments tend to align with the field.

Capacitors and Capacitance:

A capacitor is a system of two conductors separated by an insulator. If two conductors have a potential difference between them then, as any potential difference is able to accelerate charges, the system effectively stores energy. Such a device that can maintain a potential difference, storing energy by storing charge is called capacitor. When charges $+Q$ and $-Q$ are given to two plates, a potential difference is developed between the plates. The capacitance of the arrangement is defined as.

$$C = \frac{Q}{V}$$

Definition of Capacitance: Capacitance is defined as the amount of charge required to raise the potential of a conductor by one volt.

Capacity of an isolated spherical conductor:

Consider a sphere with center O and radius r , which is supplied with a charge $= +q$. This charge is distributed uniformly over the outer surface of the sphere. Thus, the potential at every point on the surface is same and is given by.

$$V = \frac{q}{4\pi\epsilon_0 r}$$

$$\text{As } C = \frac{Q}{V}$$

$$C = 4\pi\epsilon_0 r$$

The Parallel Plate Capacitor:

The arrangement consists of two thin conducting plates, each of area A and separated by a small distance d . When charge q is given to first plate, a charge $-q$ is induced on the inner face of other plate and positive on the outer face of plate. As this face is connected to earth, a net negative charge is left on this plate. Thus, the arrangement is equivalent to two thin sheets of charge. As d is much smaller than the linear dimension of the plates ($d^2 \ll A$), we can use the result of electric field by an infinite sheet of charge. The electric field between the plates is.

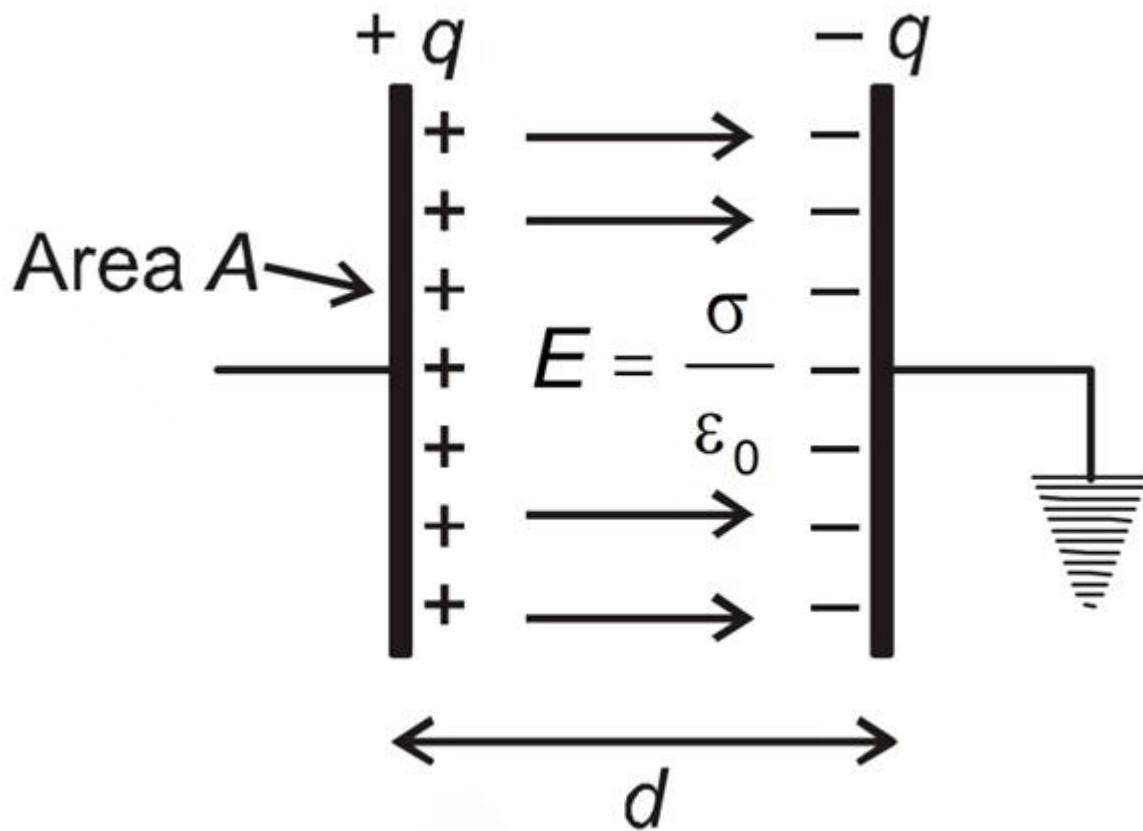

$$E = \frac{\sigma}{2\epsilon_0} + \frac{\sigma}{2\epsilon_0}$$

$$E = \frac{\sigma}{\epsilon_0} \dots (1)$$

For uniform field potential difference between the plates.

$$V = Ed = \frac{\sigma d}{\epsilon_0} \dots \text{From eq (1)}$$

$$V = \frac{qd}{\epsilon_0 A} \text{ as } \sigma = \frac{q}{A}$$

$$C = \frac{q}{V} = \frac{q}{\frac{qd}{\epsilon_0 A}}$$

$$C = \frac{\epsilon_0 A}{d}$$

Effect of Dielectric on Capacitance:

When a dielectric slab of dielectric constant K is inserted between the plates filling the entire space between the plates. The plates of the capacitor are given charge $+Q$ and $-$

Q and hence induced charges $-QP$ and $+QP$ appear on the surfaces of the slab. So, capacitance is increased to K times when the space between the plates is filled with a dielectric of dielectric constant K .

Combination of Capacitors:

Series Grouping:

The arrangements shown in figure are examples of series grouping. When capacitors can be arranged in a row, so that there is no connection from in between two capacitors to any third capacitor, it is called a series combination. Or, when same charge flows through each capacitor connected.

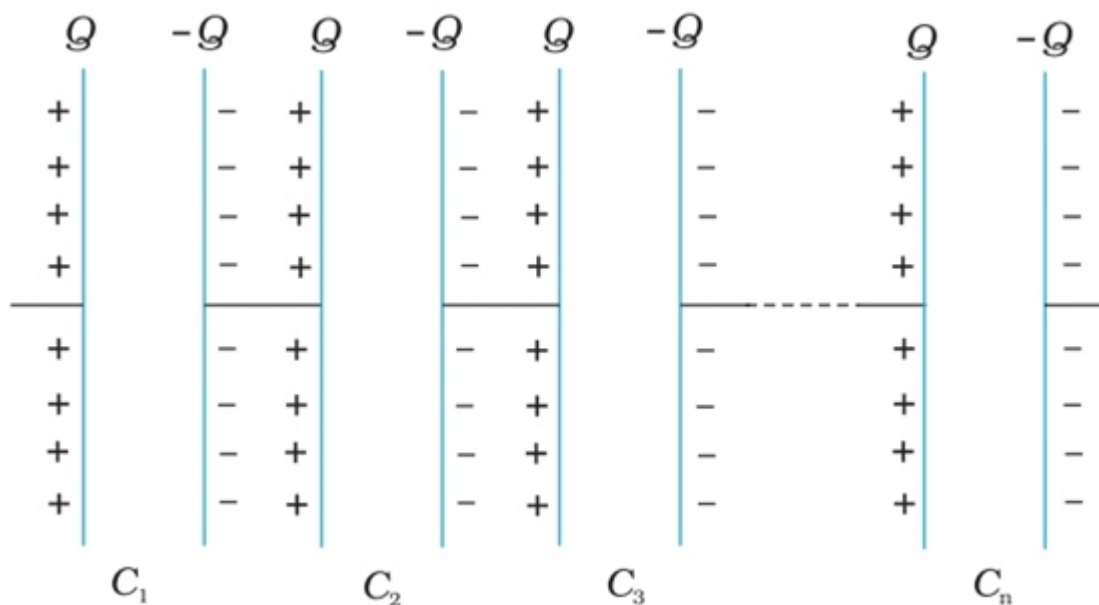

$$\frac{1}{C} = \frac{1}{C_1} + \frac{1}{C_2} + \frac{1}{C_3}$$

Parallel Grouping: The arrangements shown in figure are examples of parallel combination. When two or more capacitors are connected between two given points, they are said to be in parallel. Or, when capacitor bears same potential difference across it.

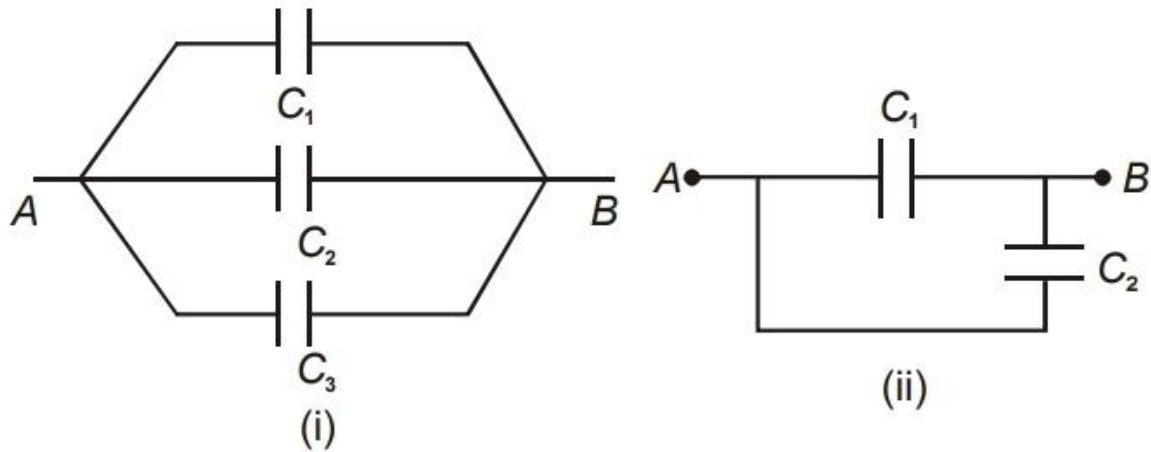

$$C = C_1 + C_2 + C_3$$

Van de Graaff Generator:

Van de Graaff generator is a machine that can built up voltages in order of a few million volts. The resultant electric fields are used to accelerate charged particles (proton, electrons, ions) to high energies required for experiments to examine small scale structure of matter.

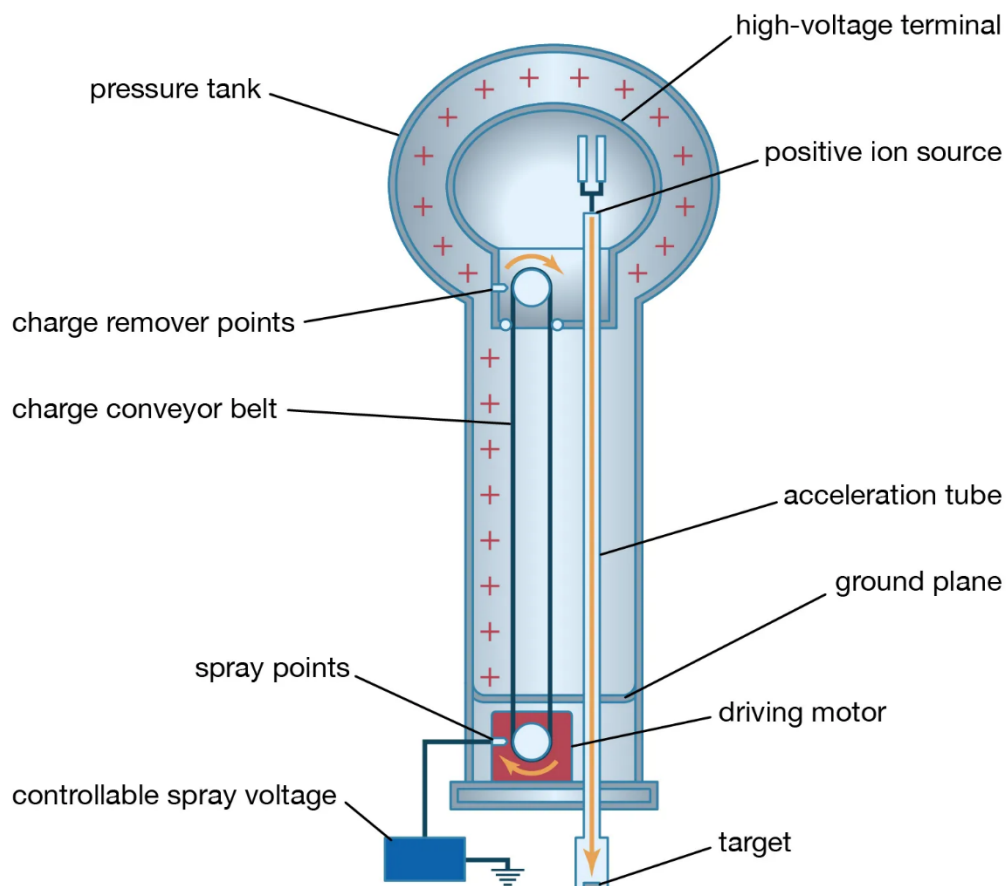

Class : 12th Physics
Chapter- 2 : Electrostatic Potential and Capacitance

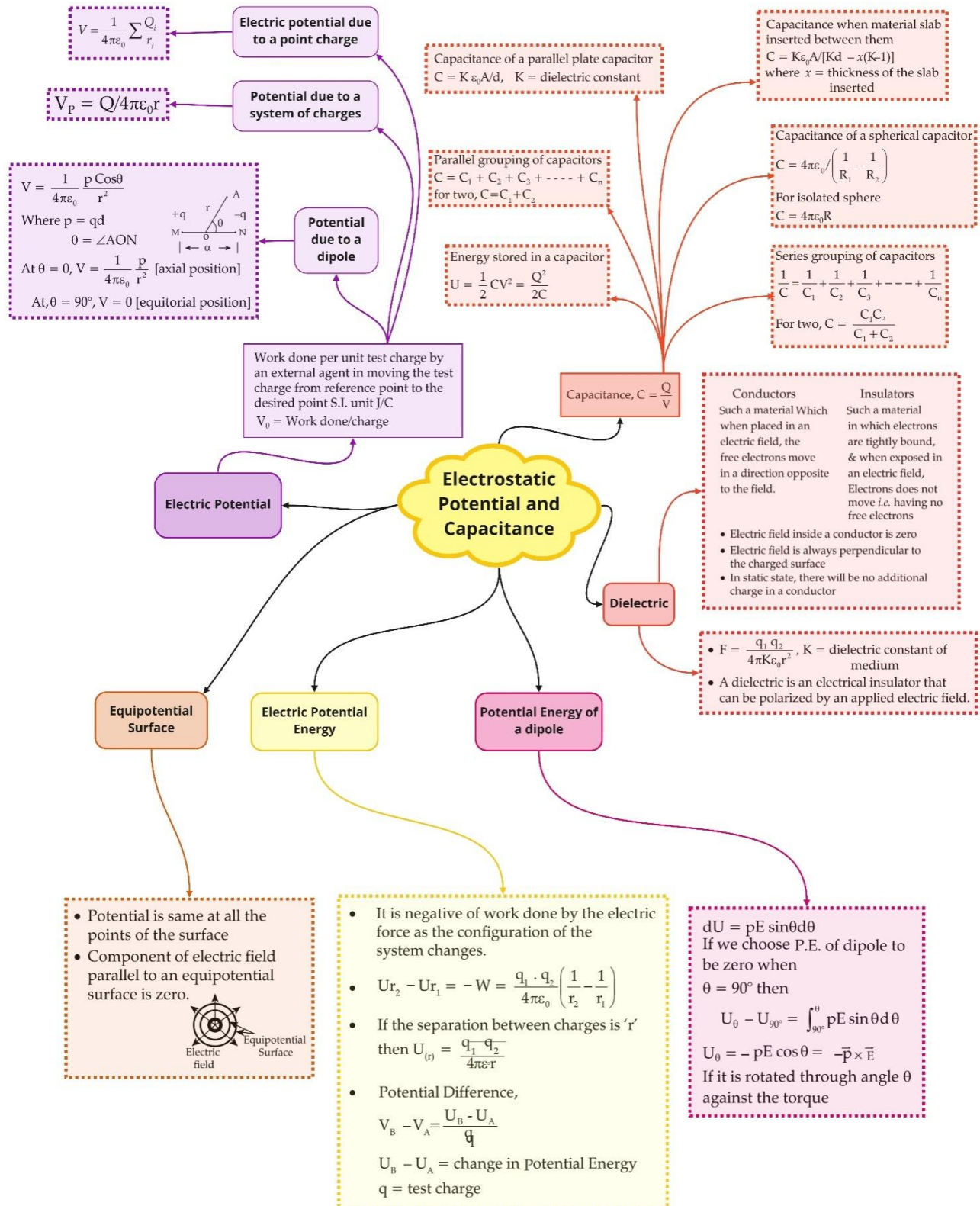

Important Questions

Multiple Choice questions-

1. Which of the following statement is true?

- (a) Electrostatic force is a conservative force.
- (b) Potential at a point is the work done per unit charge in bringing a charge from any point to infinity.
- (c) Electrostatic force is non-conservative
- (d) Potential is the product of charge and work.

2. 1 volt is equivalent to

- | | |
|---|--|
| (a) $\frac{\text{newton}}{\text{second}}$ | (b) $\frac{\text{newton}}{\text{coulomb}}$ |
| (c) $\frac{\text{joule}}{\text{coulomb}}$ | (d) $\frac{\text{joule}}{\text{second}}$ |

3. The work done in bringing a unit positive charge from infinite distance to a point at distance x from a positive charge Q is W . Then the potential at that point is

- | | |
|--------------------|----------|
| (a) $\frac{WQ}{x}$ | (b) W |
| (c) $\frac{W}{x}$ | (d) WQ |

4. Consider a uniform electric field in the z -direction. The potential is a constant

- (a) for any x for a given z
- (b) for any y for a given z
- (c) on the x - y plane for a given z
- (d) all of these

5. Equipotential surfaces

- (a) are closer in regions of large electric fields compared to regions of lower electric fields.
- (b) will be more crowded near sharp edges of a conductor.
- (c) will always be equally spaced.
- (d) both (a) and (b) are correct.

6. In a region of constant potential

- (a) the electric field is uniform.
- (b) the electric field is zero.

- (c) there can be no charge inside the region.
- (d) both (b) and (c) are correct.
7. A test charge is moved from lower potential point to a higher potential point. The potential energy of test charge will
- (a) remain the same
- (b) increase
- (c) decrease
- (d) become zero
8. An electric dipole of moment \vec{P} is placed in a uniform electric field \vec{E} . Then
- (i) the torque on the dipole is $\vec{P} \times \vec{E}$
- (ii) the potential energy of the system is $\vec{P} \cdot \vec{E}$
- (iii) the resultant force on the dipole is zero. Choose the correct option.
- (a) (i), (ii) and (iii) are correct
- (b) (i) and (iii) are correct and (ii) is wrong
- (c) only (i) is correct
- (d) (i) and (ii) are correct and (iii) is wrong
9. If a conductor has a potential $V \neq 0$ and there are no charges anywhere else outside, then
- (a) there must be charges on the surface or inside itself.
- (b) there cannot be any charge in the body of the conductor.
- (c) there must be charges only on the surface.
- (d) both (a) and (b) are correct.
10. Which of the following statements is false for a perfect conductor?
- (a) The surface of the conductor is an equipotential surface.
- (b) The electric field just outside the surface of a conductor is perpendicular to the surface.
- (c) The charge carried by a conductor is always uniformly distributed over the surface of the conductor.
- (d) None of these.

Very Short:

1. Express dielectric constant in terms of the capacitance of a capacitor.

- On what factors does the capacitance of a parallel plate capacitor depend?
- What is the ratio of electric field intensities at any two points between the plates of a capacitor?
- Write a relation between electric displacement vector D and electric field E .
- Write the relation between dielectric constant (K) and electric susceptibility χ_e .
- A hollow metal sphere of radius 5 cm is charged such that the potential on its surface is 10 V. What is the potential at the center of the sphere? (CBSE AI 2011)
- What is the geometrical shape of equipotential surfaces due to a single isolated charge? (CBSE Delhi 2013)
- Draw the equipotential surfaces due to an isolated point charge. (CBSE Delhi 2019)
- 'For any charge configuration, equipotential surface through a point is normal to the electric field'. Justify. (CBSE Delhi 2014)
- The given graph shows the variation of charge 'q' versus potential difference 'V' for two capacitors C_1 and C_2 . Both the capacitors have the same plate separation but the plate area of C_2 is greater than that of C_1 . Which line (A or B) corresponds to C_1 and why? (CBSE AI 2014C)

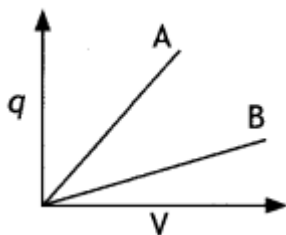

Short Questions:

- Draw a plot showing the variation of (i) electric field (E) and (ii) electric potential (V) with distance r due to a point charge Q . (CBSE Delhi 2012)
- Two identical capacitors of 10 pF each are connected in turn (i) in series and (ii) in parallel across a 20 V battery. Calculate the potential difference across each capacitor in the first case and the charge acquired by each capacitor in the second case. (CBSE AI 2019)
- A point charge 'q' is placed at O as shown in the figure. Is $V_A - V_B$ positive, negative, or zero, if 'q' is an (i) positive, (ii) negative charge? (CBSE Delhi 2011, 2016).

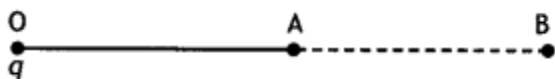

4. The graph shows the variation of voltage V across the plates of two capacitors A and B versus charge Q stored on them. Which of the two capacitors has higher capacitance? Give a reason for your answer.

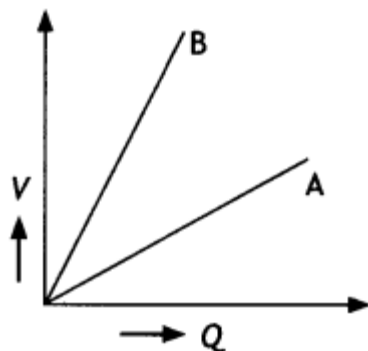

5. A test charge ' q ' is moved without acceleration from A to C along the path from A to B and then from B to C in electric field E as shown in the figure,

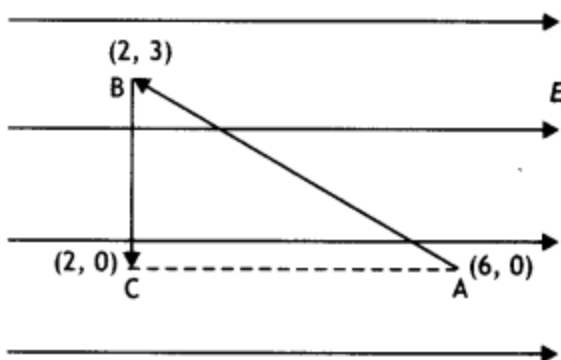

- (i) Calculate the potential difference between A and C
- (ii) At which point (of the two) is the electric potential more and why? (CBSE AI 2012)

6. A slab of material of dielectric constant K has the same area as that of the plates of a parallel plate capacitor but has the thickness $d/2$, where d is the separation between the plates. Find out the expression for its capacitance when the slab is inserted between the plates of the capacitor. (CBSE AI 2013)

7. Two-point charges q and $-2q$ are kept ' d ' distance apart. Find the location of the point relative to charge ' q ' at which potential due to this system of charges is zero. (CBSE AI 2014C)

8. Four-point charges Q , q , Q , and q are placed at the corners of a square of side ' a ' as shown in the figure.

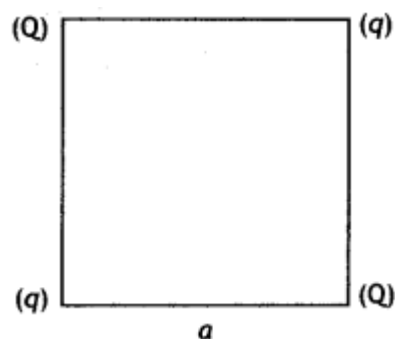

Find the potential energy of this system. (CBSEAI, Delhi 2018)

Long Questions:

1. Two-point charges $2 \mu\text{C}$ and $-2 \mu\text{C}$ are placed at points A and B 6 cm apart.

(a) Draw the equipotential surfaces of the system.

(b) Why do the equipotential surfaces get closer to each other near the point charges?
(CBSEAI2011C)

2.

(a) Obtain the expressions for the resultant capacitance when the three capacitors C_1 , C_2 , and C_3 are connected (i) in parallel and then (ii) in series.

(b) In the circuit shown in the figure, the charge on the capacitor of $4 \mu\text{F}$ is $16 \mu\text{C}$. Calculate the energy stored in the capacitor of $12 \mu\text{F}$ capacitance. (CBSE 2019C)

Assertion and Reason Questions-

1. For two statements are given-one labelled Assertion (A) and the other labelled Reason (R). Select the correct answer to these questions from the codes (a), (b), (c) and (d) as given below.

- Both A and R are true, and R is the correct explanation of A.
- Both A and R are true, but R is not the correct explanation of A.
- A is true, but R is false.
- A is false, and R is also false.

Assertion (A): An electric field is preferred in comparison to magnetic field for detecting the electron beam in a television picture tube.

Reason (R): Electric field requires low voltage.

2. For two statements are given-one labelled Assertion (A) and the other labelled Reason (R). Select the correct answer to these questions from the codes (a), (b), (c) and (d) as given below.

- Both A and R are true, and R is the correct explanation of A.

- b) Both A and R are true, but R is not the correct explanation of A.
 c) A is true, but R is false.
 d) A is false, and R is also false.

Assertion (A): An applied electric field will polarize the polar dielectric material.

Reason (R): In polar dielectrics, each molecule has a permanent dipole moment but these are randomly oriented in the absence of an externally applied electric field.

Case Study Questions-

1. When an insulator is placed in an external field, the dipoles become aligned. Induced surface charges on the insulator establish a polarization field \vec{E}_i in its interior. The net field \vec{E} in the insulator is the vector sum of \vec{E}_0 and \vec{E}_i as shown in the figure.

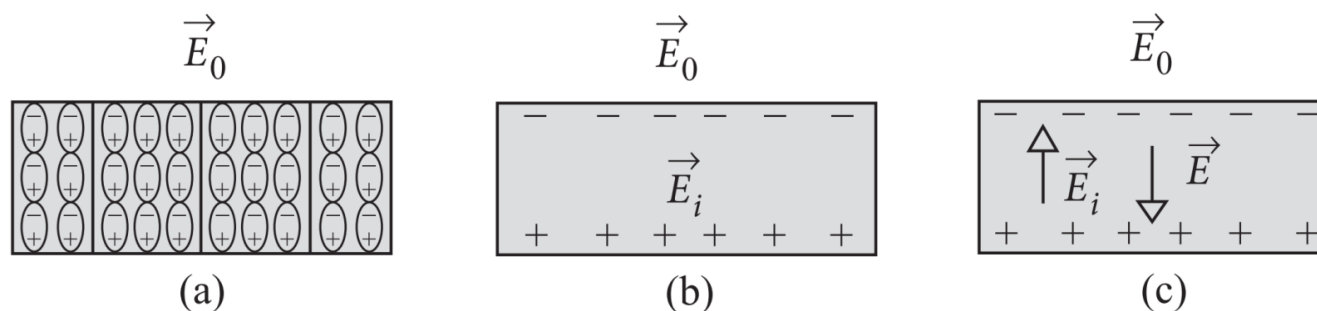

On the application of external electric field, the effect of aligning the electric dipoles in the insulator is called polarisation, and the field is known as the polarisation field.

The dipole moment per unit volume of the dielectric is known as polarisation \vec{P} . For linear isotropic dielectrics, $\vec{P} = \chi \vec{E}$, where χ = electrical susceptibility of the dielectric medium.

- (i) Which among the following is an example of polar molecule?
- O_2
 - H_2
 - N_2
 - HCl
- (ii) When air is replaced by a dielectric medium of constant K, the maximum force of attraction between two charges separated by a distance:
- Increases K times.
 - Remains unchanged.
 - Decreases K times.

- d) Increases 2K times.
- (iii) Which of the following is a dielectric?
- Copper.
 - Glass.
 - Antimony (Sb).
 - None of these.
- (iv) For a polar molecule, which of the following statements is true?
- The centre of gravity of electrons and protons coincide.
 - The centre of gravity of electrons and protons do not coincide.
 - The charge distribution is always symmetrical.
 - The dipole moment is always zero.
- (v) When a comb rubbed with dry hair attracts pieces of paper. This is because the?
- Comb polarizes the piece of paper.
 - Comb induces a net dipole moment opposite to the direction of field.
 - Electric field due to the comb is uniform.
 - Comb induces a net dipole moment perpendicular to the direction of field.

2. This energy possessed by a system of charges by virtue of their positions. When two like charges lie infinite distance apart, their potential energy is zero because no work has to be done in moving one charge at infinite distance from the other.

In carrying a charge q from point A to point B, work done $W = q(V_A - V_B)$. This work

may appear as change in $\frac{KE}{PE}$ of the charge. The potential energy of two charges q_1 and

q_2 at a distance r in air is $\frac{q_1 q_2}{4\pi\epsilon_0 r}$.

It is measured in joule. It may be positive, negative or zero depending on the signs of q_1 and q_2 .

- i. Calculate work done in separating two electrons from a distance of 1m to 2m in air, where e is electric charge and k is electrostatic force constant.

- a. ke^2
- b. $\frac{e^2}{2}$
- c. $-\frac{ke^2}{2}$
- d. Zero

- ii. Four equal charges q each are placed at four corners of a square of side a each. Work done in carrying a charge $-q$ from its centre to infinity is:

- a. **Zero**
- b. $\frac{\sqrt{2}q^2}{\pi\epsilon_0 a}$
- c. $\frac{\sqrt{2}q}{\pi\epsilon_0 a}$
- d. $\frac{q^2}{\pi\epsilon_0 a}$

- iii. Two points A and B are located in diametrically opposite directions of a point charge of $+2\mu\text{C}$ at distances 2m and 1m respectively from it. The potential difference between A and B is:

- a. $3 \times 10^3\text{V}$
- b. $6 \times 10^4\text{V}$
- c. $-9 \times 10^3\text{V}$
- d. $-3 \times 10^3\text{V}$

- iv. Two point charges $A = + 3\text{nC}$ and $B = + 1\text{nC}$ are placed 5cm apart in air.

The work done to move charge B towards A by 1cm is:

- a. $2.0 \times 10^{-7}\text{J}$
- b. $1.35 \times 10^{-7}\text{J}$
- c. $2.7 \times 10^{-7}\text{J}$
- d. $12.1 \times 10^{-7}\text{J}$

v. A charge Q is placed at the origin. The electric potential due to this charge at a given point in space is V . The work done by an external force in bringing another charge q from infinity up to the point is:

- a. $\frac{V}{q}$
- b. Vq
- c. $V + q$
- d. V

✓ Answer Key:

Multiple Choice Answers-

1. Answer: a
2. Answer: c
3. Answer: b
4. Answer: d
5. Answer: d
6. Answer: d
7. Answer: c
8. Answer: b
9. Answer: c
10. Answer: d

Very Short Answers:

1. Answer: It is given by the expression $K = \frac{C}{C_0}$ where C is the capacitance of the capacitor with dielectric and C_0 is the capacitance without the dielectric.
2. Answer:
 - Area of plates,
 - The separation between the plates and
 - Nature of dielectric medium between the plates.
3. Answer: The ratio is one, as the electric field is the same at all points between the plates of a capacitor.
4. Answer:

$$\vec{D} = \epsilon_0 \vec{E} + \vec{P}$$
5. Answer: $K = 1 + \chi_e$

6. Answer: 10 V
 7. Answer: Concentric circles.
 8. Answer: These areas are shown.

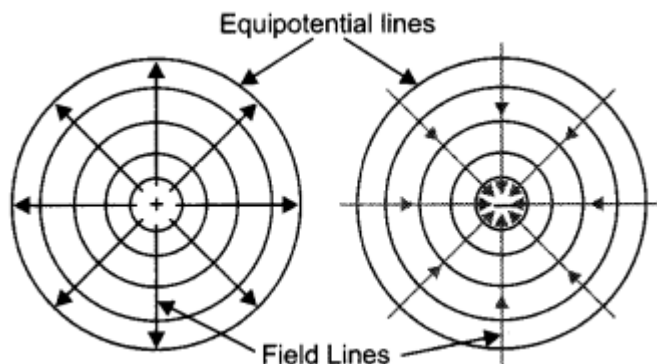

9. Answer: This is because work done in moving a charge on an equipotential surface is zero. This is possible only if the equipotential surface is perpendicular to the electric field.
 10. Answer: Since $C = \epsilon_0 A/d$, since the area for C_2 is more, therefore capacitance of C_2 is more. From the graph greater the slope greater is than the capacitance, therefore, graph A belongs to capacitor C_2 . While graph B belongs to capacitance C_v .

Short Questions Answers:

Answer: The plot is as shown.

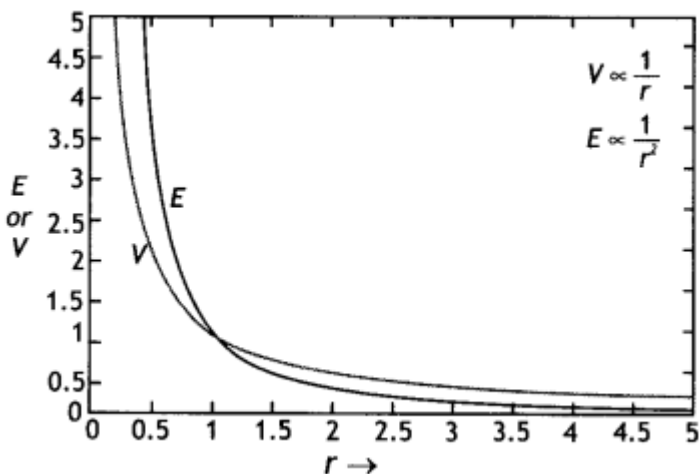

Answer:

- (i) Since the two capacitors have the same capacitance, therefore, the potential will be divided amongst them. Hence $V = 10$ V each
 (ii) Since the capacitors are connected in parallel, therefore, potential difference = 20 V

Hence charge $Q = CV = 10 \times 20 = 200$ pC

Answer:

$$\text{If } V_A - V_B = \frac{q}{4\pi\epsilon_0} \left(\frac{1}{OA} - \frac{1}{OB} \right)$$

As $OA < OB$

\therefore If q is positive then $V_A - V_B$ is positive and

if q is negative $V_A - V_B$ is also negative.

Answer:

Capacitor A has higher capacitance. We know that capacitance $C = Q/V$.

For capacitor A

$$C_A = \frac{Q}{V_A}$$

For capacitor B

$$C_B = \frac{Q}{V_B}$$

As $V_B > V_A$

$\therefore C_B < C_A$

Thus, capacitance of A is higher.

Answer:

$$(i) dV = -E dr = -E(6 - 2) = -4E$$

(ii) Electric potential is more at point C as $dV = -E dr$, i.e. the electric potential decreases in the direction of the electric field.

Answer:

Given $t = d/2$, $C = ?$

We know that when a dielectric of thickness 't' is inserted between the plates of a capacitor, its capacitance is given by

$$C = \frac{\epsilon_0 A}{d - t + \frac{t}{K}}$$

Hence we have

$$C = \frac{\epsilon_0 A}{d - \frac{d}{2} + \frac{d}{2K}} = \frac{2K\epsilon_0 A}{d(1+K)}$$

Answer:

Let the potential be zero at point P at a distance x from charge q as shown

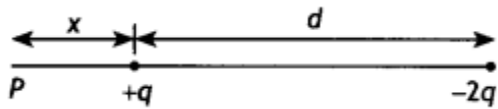

Now potential at point P is

$$V = \frac{kq}{x} + \frac{k(-2q)}{d+x} = 0$$

Solving for x we have

$$x = d$$

Answer:

The potential energy of the system

$$U = \frac{1}{4\pi\epsilon_0} \left(4\frac{qQ}{a} + \frac{q^2}{a\sqrt{2}} + \frac{Q^2}{a\sqrt{2}} \right)$$

$$U = \frac{1}{4\pi\epsilon_0 a} \left(4qQ + \frac{q^2}{\sqrt{2}} + \frac{Q^2}{\sqrt{2}} \right)$$

Long Questions Answers:

1. Answer:

(a) The diagram is as shown.

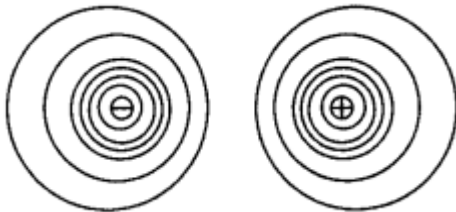

(b) We know that $E = -dV/dr$

Therefore, $dr = -dV/E$

Since near the charge, electric field E is large, dr will be less.

2. Answer:

(i) Parallel combination of three capacitors.

Let three capacitors of capacitances C_1 , C_2 , and C_3 be connected in parallel, and potential difference V be applied across A and B. If q be total charge flowing in the circuit and q_1 , q_2 and q_3 be charges flowing across.

C_1 , C_2 , and C_3 respectively, then

$$q = q_1 + q_2 + q_3$$

$$\text{or } q = C_1V + C_2V + C_3V \dots(i)$$

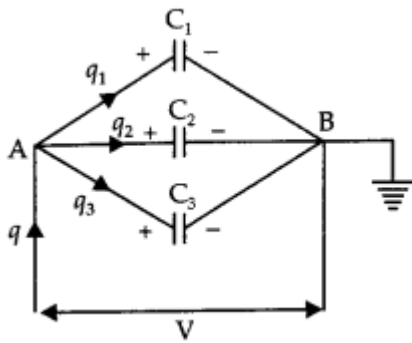

If C_P is the capacitance of the arrangement in parallel, then

$$q = C_P V$$

So equation (i) becomes

$$C_P V = C_1 V + C_2 V + C_3 V$$

Or

$$C_P = C_1 + C_2 + C_3$$

(ii) Series combination of three capacitors Let three capacitors C_1 , C_2 , and C_3 be connected in series. Let q charge be flowing through the circuit.

If V_1 , V_2 , and V_3 be potential differences across the plates of the capacitor and V be the potential difference across the series combination, then

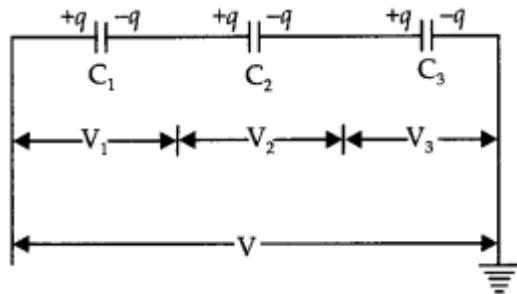

$$V = V_1 + V_2 + V_3$$

Or

$$V = \frac{q}{C_1} + \frac{q}{C_2} + \frac{q}{C_3} \dots (i)$$

If C_s is the capacitance of series combination, then $V = \frac{q}{C_s}$.

So the equation (i) becomes

$$\frac{q}{C_s} = \frac{q}{C_1} + \frac{q}{C_2} + \frac{q}{C_3}$$

Or

$$\frac{1}{C_s} = \frac{1}{C_1} + \frac{1}{C_2} + \frac{1}{C_3}$$

Charge q across $4 \mu\text{F}$ Capacitor is $10 \mu\text{C}$ Potential difference across the capacitor of capacitance $4 \mu\text{F}$ will be

$$V = \frac{q}{C} = \frac{16\mu\text{C}}{4\mu\text{F}} = \frac{16 \times 10^{-6}\text{C}}{4 \times 10^{-6}\text{F}} = 4\text{V}$$

\therefore Potential across 12 μF Capacitors

$$= 12\text{V} - 4\text{V} = 8\text{V}$$

Energy stored in the capacitors of capacitance $C = 12 \mu\text{F}$

$$U = \frac{1}{2} CV^2 = \frac{1}{2} \times 12 \times 10^{-6} \times 8^2 \text{ joule}$$

$$= 384 \times 10^{-6} \text{ J} = 384 \mu\text{J}$$

Assertion and Reason Answers-

1. (d) A is false, and R is also false.

Explanation:

If electric field is used for detecting the electron beam, then very high voltage will have to be applied and very long tube will have to be taken.

2. (b) Both A and R are true, but R is not the correct explanation of A.

Explanation:

If a material contain polar molecules, they will generally be in random orientations when no electric field is applied. An applied electric field will polarize the material by orienting the dipole moment of polar molecules.

Case Study Answers-

1. Answer :

(i) (d) HCl

Explanation:

In polar molecule the centres of positive and negative charges are separated even when there is no external field. Such molecule have a permanent dipole moment. Ionic molecule like HCl is an example of polar molecule.

(ii) (c) Decreases K times.

Explanation:

$$\text{As } F_m = \frac{F_0}{K}$$

\therefore The maximum force decreases by Klimes.

(iii) (b) Glass.

(iv) (b) The centre of gravity of electrons and protons do not coincide.

Explanation:

A polar molecule is one in which the centre of gravity for positive and negative charges are separated.

(v) (a) Comb polarizes the piece of paper.

2. Answer :

i. (c) $-\frac{ke^2}{2}$

Explanation:

$$W = (\text{P.E.})_{\text{final}} - (\text{P.E.})_{\text{initial}}$$

$$= \frac{ke^2}{2} - \frac{ke^2}{1} = -\frac{ke^2}{2}$$

ii. (b) $\frac{\sqrt{2}q^2}{\pi\epsilon_0 a}$

Explanation:

Potential at the centre of the square due to four equal charges q at four corners,

$$V = \frac{4q}{\frac{4\pi\epsilon_0(a\sqrt{2})}{2}} = \frac{\sqrt{2}q}{\pi\epsilon_0 a}$$

$$W_{0 \rightarrow \infty} = -W_{0 \rightarrow \infty} = -(-q)V$$

$$= \frac{\sqrt{2}q^2}{\pi\epsilon_0 a}$$

iii. (c) $-9 \times 10^3 \text{V}$

Explanation:

Here, $q = 2\mu\text{C} = 2 \times 10^{-6} \text{C}$, $r_A = 2\text{m}$, $r_B = 1\text{m}$.

$$\therefore V_A - V_B = \frac{q}{4\pi\epsilon_0} \left[\frac{1}{r_A} - \frac{1}{r_B} \right]$$

$$= 2 \times 10^{-6} \times 9 \times 10^9 \left[\frac{1}{2} - \frac{1}{1} \right]$$

$$V = -9 \times 10^3 \text{V}.$$

iv. (b) $1.35 \times 10^{-7} \text{ J}$

Explanation:

Required work done = Change in potential energy of the system,

$$\begin{aligned} W &= U_f - U_i = k \frac{q_1 q_2}{r_f} - k \frac{q_1 q_2}{r_i} \\ &= k q_1 q_2 \left[\frac{1}{r_f} - \frac{1}{r_i} \right] \\ \therefore W &= (9 \times 10^9)(3 \times 10^{-9} \times 1 \times 10^{-9}) \\ &\times \left[\frac{1}{4 \times 10^{-2}} - \frac{1}{5 \times 10^{-2}} \right] \\ &= 27 \times 10^{-7} \times (0.05) = 1.35 \times 10^{-7} \text{ J}. \end{aligned}$$

v. (b) Vq



C V RAMAN
P U C O L L E G E
I N D I

CHAPTER 3: CURRENT ELECTRICITY

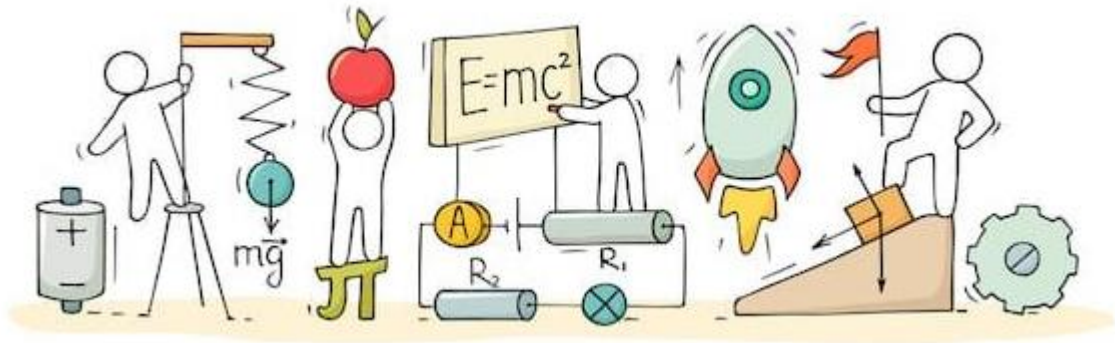

CURRENT ELECTRICITY

Introduction:

We considered all charges whether free or bound to be at rest in previous two chapters. Charges in motion constitute an electric current. Lightening is one of the natural phenomena in which charges flow from clouds to earth through the atmosphere.

In this chapter we will study some basic laws concerning steady electric current and their applications.

Electric Current:

The rate of flow of electric charge through any cross-section of a conductor is known as electric current. If ΔQ amount of charge flows through any cross-section of conductor in the interval t to $(t + \Delta t)$, then it is defined as

$$i = \frac{\Delta Q}{\Delta t}$$

Direction of current is taken as direction of motion of positively charged particles and opposite to the direction of negatively charged particles. SI unit of current is ampere (A). It is a scalar quantity.

$$\vec{j} = \frac{\Delta i}{\Delta A}$$

The SI unit of current density is A/m^2 .

Drift Speed:

Drift Velocity is defined as the average velocity with which the free electrons move towards the positive end of a conductor under the influence of an external electric field applied. It is denoted by v_d .

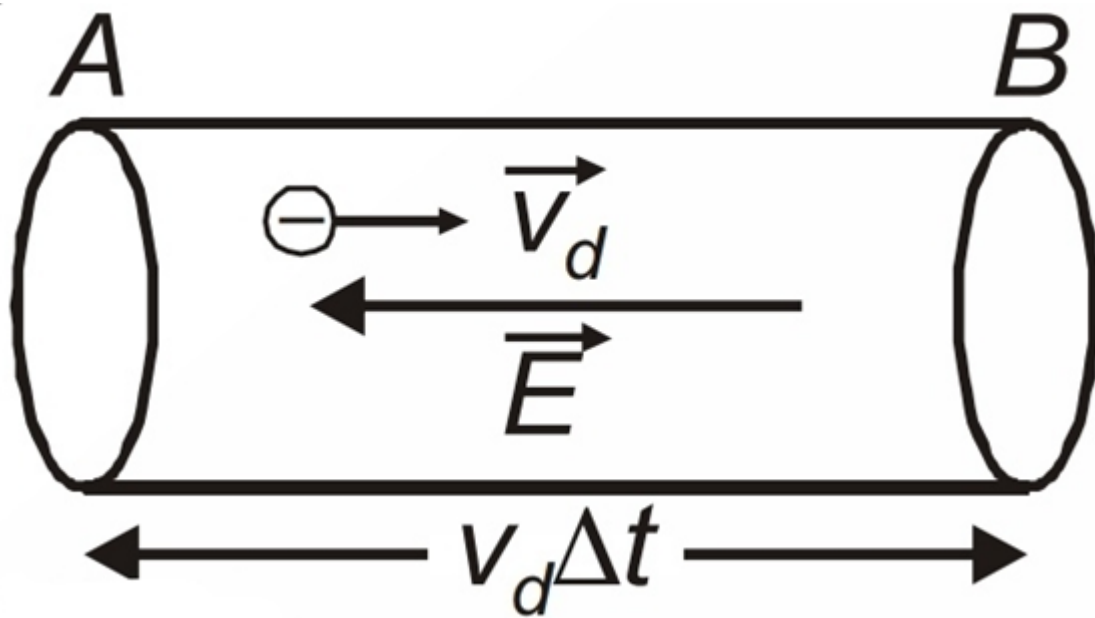

$$v_d = \frac{eE}{m}$$

Relation between Current Density and Drift Speed:

Let, cross sectional area of any conductor be A , number of electrons per unit area be n , drift velocity be v_d , then number of total moving electrons in t second will be.

$$N = (nAv_d t)$$

So, moving charge in t second $Q = (nAv_d t).e$

Hence, electric current in t second $= \frac{Q}{t}$

$$i = \frac{nAv_d t e}{t}$$

$$i = neAv_d$$

$$\text{We know } J = \frac{i}{A}$$

Putting $i = neAv_d$ in above equation

$$\vec{j} = nev_d$$

Ohm's Law:

According to this law, "At constant temperature, the potential difference V across the

ends of a given metallic wire (conductor) in an circuit (electric) is directly proportional to the current flowing through it". i.e.,

$$V \propto i$$

$$V = i.R$$

where, R = resistance of conductor

Mobility:

Mobility is defined as the magnitude of the drift velocity per unit electric field. It is denoted by μ ,

$$\mu = \frac{V_d}{E}$$

Its SI unit is $m^2V^{-1}s^{-1}$.

Resistance:

Resistance is the ratio of potential difference applied across the ends of conductor to the current flowing through it.

$$R = \frac{V}{i}$$

The SI unit of R is ohm (Ω).

Resistivity:

Resistivity is defined as the ratio of electric field applied at conductor to current density of conductor. It is denoted by ρ

$$\rho = \frac{E}{J} \dots (1)$$

If the length of conductor be 'l', cross sectional area be 'A', potential difference at the end of conductor be 'V' and electric current be 'i', then \vec{E} and \vec{j} given by.

$$\vec{E} = \frac{V}{l} \dots (2)$$

$$\vec{j} = \frac{i}{A} \dots (3)$$

Putting the value of E and J, from equation (2) and (3) into (1), we get.

$$\rho = \frac{V}{\frac{l}{i}}$$

$$\rho = \frac{V}{i} \cdot \frac{A}{l}$$

$$\rho = R \frac{A}{l}$$

The constant of proportionality ρ depends on the material of the conductor but not on its dimensions. ρ is known as resistivity or specific resistance.

Conductivity:

Conductivity is defined as the reciprocal of resistivity of a conductor. It is expressed as,

$$\sigma = \frac{1}{\rho}$$

SI unit is mho per meter ($\Omega^{-1} \text{ m}^{-1}$).

Superconductivity:

The resistivity of certain metal or alloy drops to zero when they are cooled below a certain temperature is called superconductivity.

Electrical Energy:

When electric current is moved in any electric circuit, then energy of work done by taking a charge from one point to another point is called electric energy.

If a charge q at potential difference V is moved from one point to another point, then doing work will be.

$$W = V \cdot q \dots\dots (1)$$

Putting $q = i \cdot t$ in equation (1), we get

$$W = Vit$$

Putting $V = i \cdot R$ in equation (1), we get

$$W = i^2 R t$$

Putting $i = V/R$ in equation (1), we get

$$W = \frac{V^2}{R} t$$

Power: Electric power is the rate of doing work by electric charge. It is measured in watt and represented by P.

$$P = \frac{W}{t} [\because 1\text{HP} = 746 \text{ watt}]$$

Hence, $P = Vi = i^2R = \frac{V^2}{R}$

Resistor Color Codes:

Colour	Number	Multiplier	Tolerance (%)
Black	0	1	
Brown	1	10^1	
Red	2	10^2	
Orange	3	10^3	
Yellow	4	10^4	
Green	5	10^5	
Blue	6	10^6	
Violet	7	10^7	
Gray	8	10^8	
White	9	10^9	
Gold		10^{-1}	5
Silver		10^{-2}	10
No colour			20

A carbon resistor has a set of coaxial colored rings in them, whose significance are listed in above table. First two bands formed: First two significant figures of the resistance in ohm. Third band; Decimal multiplier as shown in table. Last band; Tolerance or possible variation in percentage as per the indicated value. For Gold $\pm 5\%$, for silver $\pm 10\%$ and No color $\pm 20\%$.

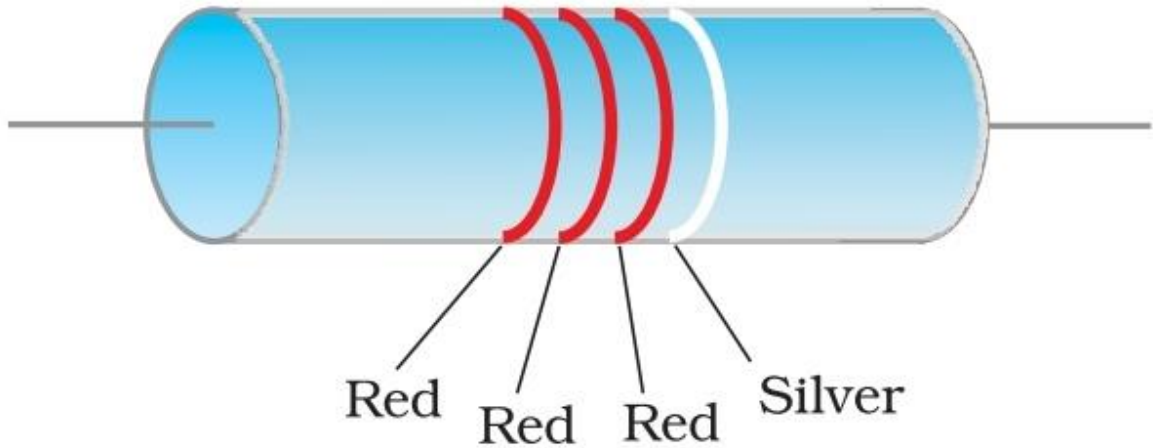

Combination of Resistors:

There are two types of resistance combinations.

Series Combination:

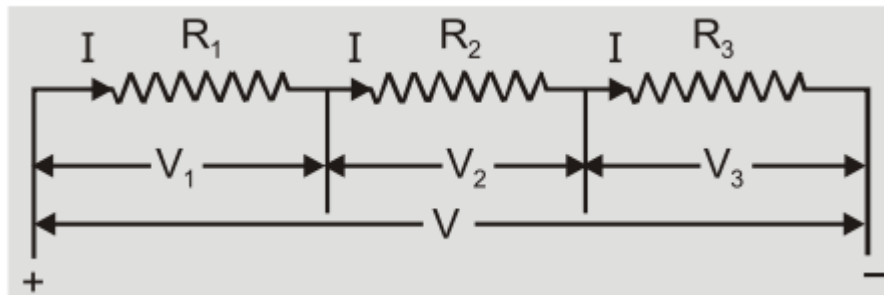

In Series Combination, different resistances are connected end to end. Equivalent resistance can be obtained as the formula,

$$R = R_1 + R_2 + R_3$$

NOTE: The total resistance in the series combination is more than the greatest resistance in the circuit.

Parallel Combination:

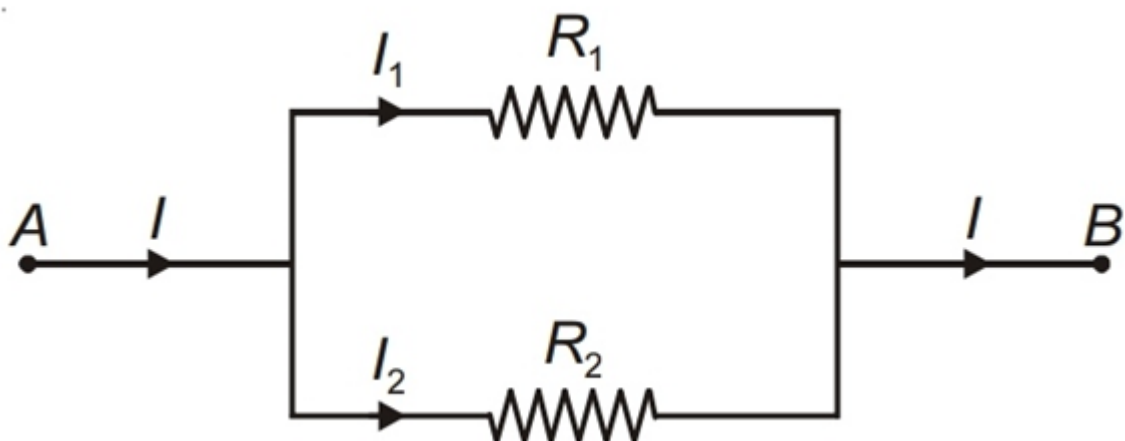

In Parallel combination, first end of all the resistances are connected to one point and last end of all the resistances are connected to other point. Equivalent resistance can be obtained by the formula.

$$\frac{1}{R} = \frac{1}{R_1} + \frac{1}{R_2} + \frac{1}{R_3}$$

NOTE: The total resistance in parallel combination is less than the least resistance of the circuit.

Cells, EMF, Internal Resistance:

Cells: An electrolytic cell consisting of two electrodes, called positive (P) and negative (N) immersed in an electrolytic solution as shown in figure.

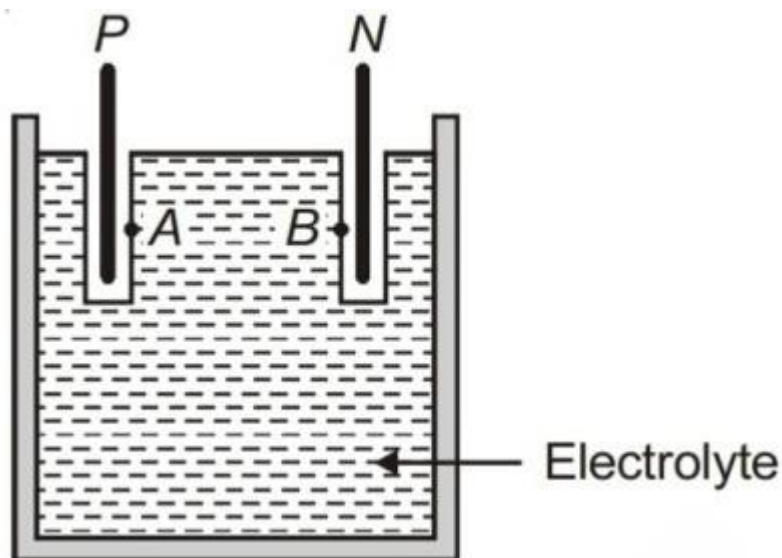

Electrodes exchange charges with the electrolyte. Positive electrode P has a potential difference $V+$ between itself and electrolyte solution A immediately adjacent to it. Negative electrode N has a potential difference ($V-$) relative to electrolyte B adjacent

to it.

$$\varepsilon = V_+ - V_-$$

EMF: It is the difference of chemical potentials of electrodes used. It is also defined as the difference of potential across the electrodes of cell, when the electrodes are in open loop.

$$\varepsilon = V_+ - V_-$$

Internal Resistance: It is the opposition offered by the electrolyte of the cell to the flow of current through itself. It is represented by r and given by.

$$r = \frac{V}{i}$$

Kirchhoff's Laws:

Kirchhoff's two rules are used for analyzing electric circuits consisting of a number of resistors and cells interconnected in a complicated way.

Kirchhoff's first rule: Junction rule

At any junction, the sum of the currents entering the junction is equal to the sum of currents leaving the junction.

$$\sum i = 0$$

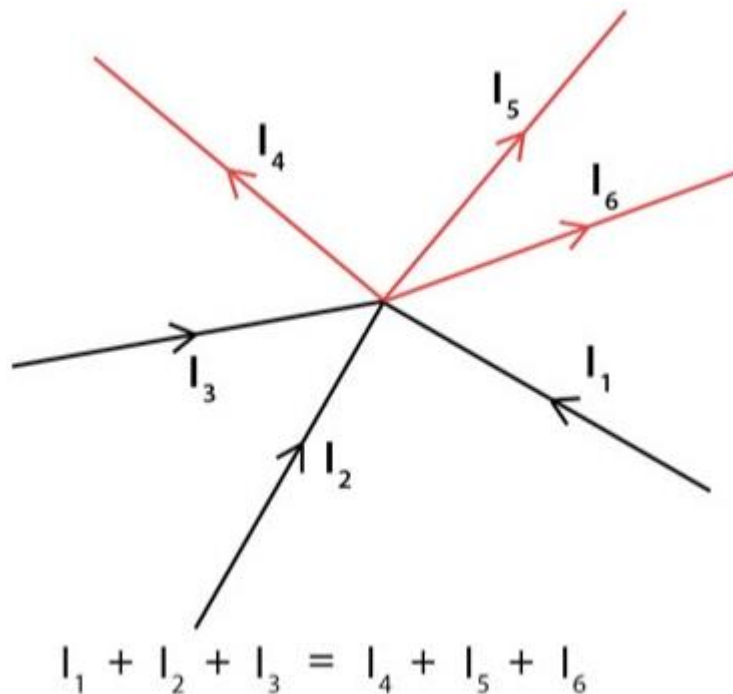

Kirchhoff's second rule: Loop rule

The algebraic sum of changes in potential around any closed loop involving resistors and cells in the loop is zero.

$$\sum iR = \sum E$$

Wheatstone Bridge:

It is an application of Kirchhoff's rules. The bridge is consisting of four resistances R_1 , R_2 , R_3 and R_4 as four sides of a square ABCD as shown in figure.

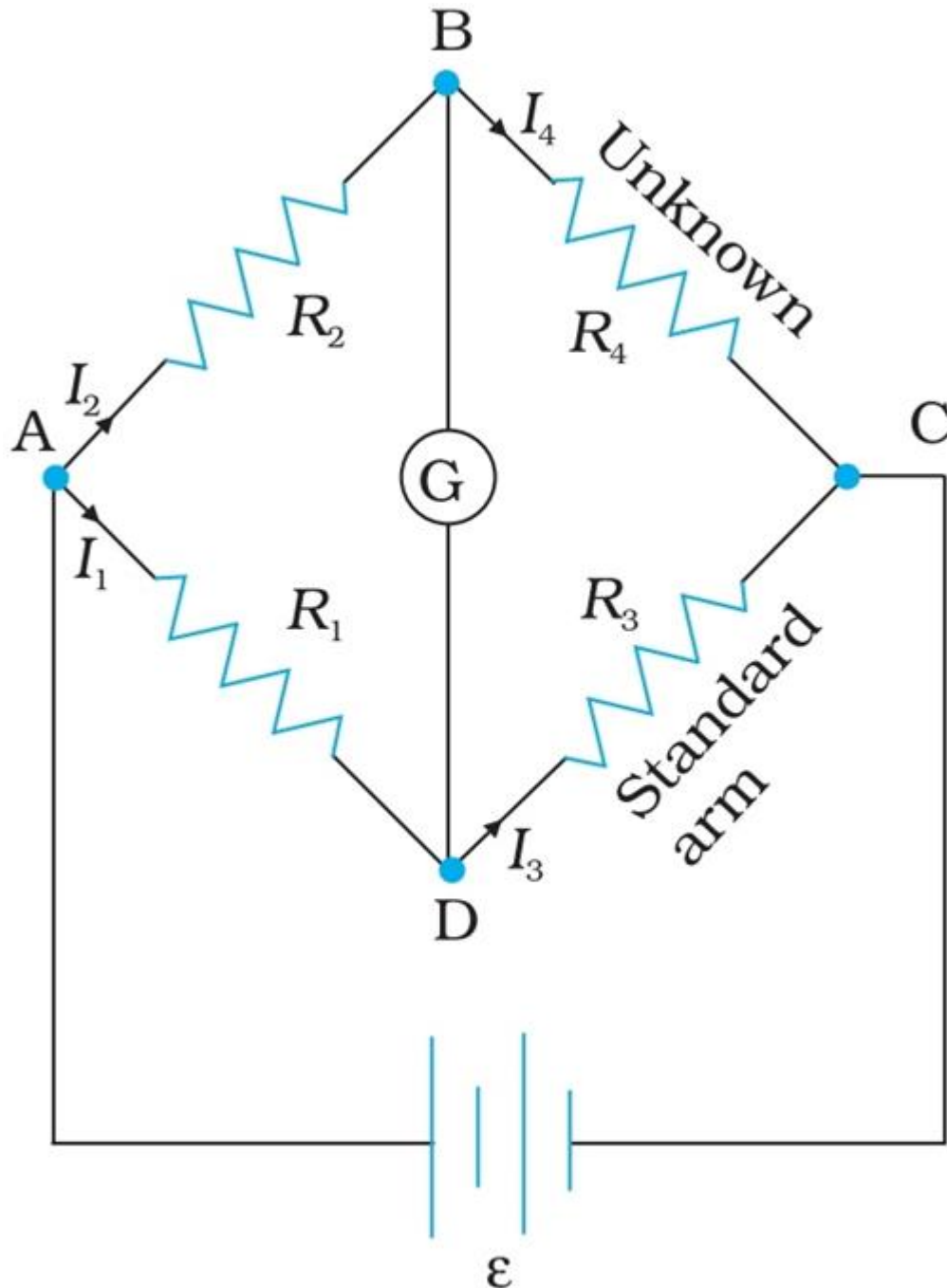

Across the diagonally opposite points between A and C, battery E is connected. This is

called battery arm. To remaining two diagonally opposite points B and D, a galvanometer G is connected to detect current. This line is known as galvanometer arm.

Currents through all resistances and galvanometer are as shown in figure. In balanced Wheatstone bridge we consider the special case $I_g = 0$. Applying junction rule to junction B and D, we have

$$I_2 = I_4 \text{ and } I_1 = I_3$$

Applying loop rule to loop ABDA

$$I_2 R_2 + 0 - I_1 R_1 = 0$$

$$\frac{I_1}{I_2} = \frac{R_2}{R_1} \dots\dots (i)$$

Applying loop rule to loop BCDB

$$I_4 R_4 - I_3 R_3 + 0 = 0$$

$$I_2 R_4 - I_1 R_3 = 0 \text{ (Using } I_4 = I_2 \text{ and } I_3 = I_1)$$

$$\frac{I_1}{I_2} = \frac{R_4}{R_3} \dots\dots (ii)$$

The equation (iii) relating the four resistor is called the balance condition for the galvanometer to give zero or null deflection.

Potentiometer:

It is a versatile instrument consisting of a long piece of uniform wire AC across which a standard cell B is connected.

Class : 12th Physics
Chapter- 3 : Current Electricity

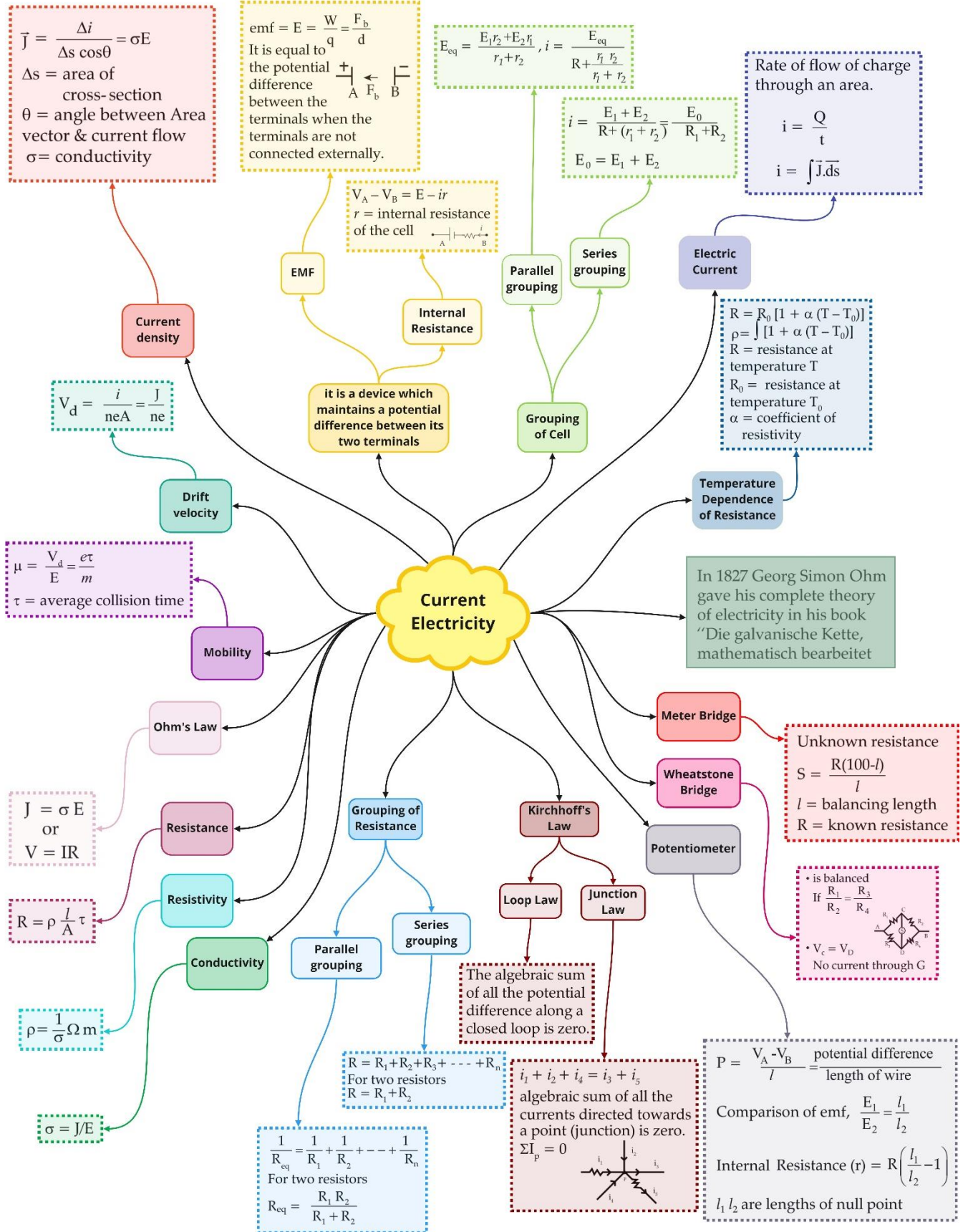

Important Questions

Multiple Choice questions-

1. An electric heater is connected to the voltage supply. After few seconds, current gets its steady value then its initial current will be

- (a) equal to its steady current
- (b) slightly higher than its steady current
- (c) slightly less than its steady current
- (d) zero

2. In the series combination of two or more than two resistances

- (a) the current through each resistance is same.
- (b) the voltage through each resistance is same.
- (c) neither current nor voltage through each resistance is same.
- (d) both current and voltage through each resistance are same.

3. Combine three resistors 5 Q, 4.5 Q and 3 Q in such a way that the total resistance of this combination is maximum

- (a) 12.5 Q
- (b) 13.5 Q
- (c) 14.5 Q
- (d) 16.5 Q

4. A cell having an emf E and internal resistance r is connected across a variable external resistance R . As the resistance R is increased, the plot of potential difference V across R is given by

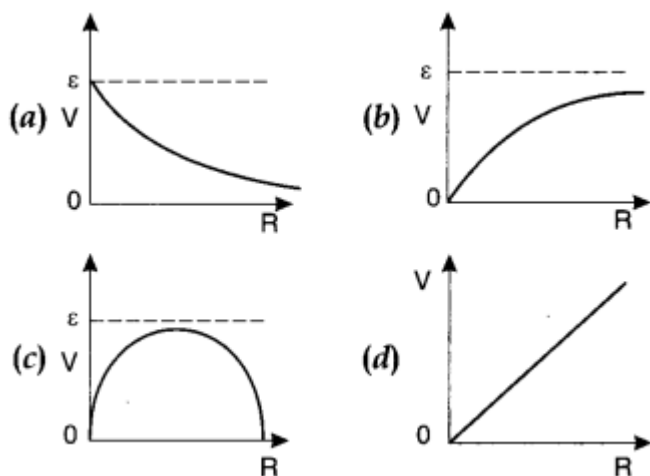

5. In parallel combination of n cells, we obtain

- (a) more voltage
- (b) more current
- (c) less voltage

(d) less current

6. If n cells each of emf e and internal resistance r are connected in parallel, then the total emf and internal resistance will be

(a) $\epsilon, \frac{r}{n}$ (b) ϵ, nr

(c) $n\epsilon, \frac{r}{n}$ (d) $n\epsilon, nr$

7. In a Wheatstone bridge if the battery and galvanometer are interchanged then the deflection in galvanometer will

- (a) change in previous direction
- (b) not change
- (c) change in opposite direction
- (d) none of these.

8. When a metal conductor connected to left gap of a meter bridge is heated, the balancing point

- (a) shifts towards right
- (b) shifts towards left
- (c) remains unchanged
- (d) remains at zero

9. In a potentiometer of 10 wires, the balance point is obtained on the 7th wire. To shift the balance point to 9th wire, we should

- (a) decrease resistance in the main circuit.
- (b) increase resistance in the main circuit.
- (c) decrease resistance in series with the cell whose emf is to be measured.
- (d) increase resistance in series with the cell whose emf is to be determined.

10. AB is a wire of potentiometer with the increase in the value of resistance R , the shift in the balance point J will be

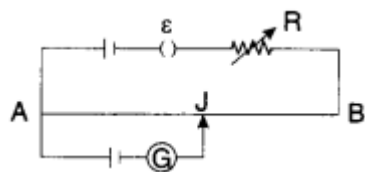

- (a) towards B
- (b) towards A
- (c) remains constant
- (d) first towards B then back towards A.

Very Short:

1. A wire of resistivity ρ is stretched to double its length. What will be its new resistivity?
2. What is the effect of temperature on the relaxation time of electrons in a metal?
3. Which physical quantity does the voltage versus current graph for a metallic conductor depict? Give its SI unit.
4. Define drift velocity of electrons.
5. A resistance R is connected across a cell of emf ϵ and internal resistance r . A potentiometer now measures the potential difference between the terminals, of the cell as V . Write the expression for ' r ' in terms of ϵ , V and R . (CBSE Delhi 2011)
6. How is the drift velocity in a conductor affected by the rise in temperature? (CBSE Delhi 2019)
7. Two students A and B were asked to pick a resistor of $15\text{ k}\Omega$ from a collection of carbon resistors. A picked a resistor with bands of colours brown, green, orange, while B chose a resistor with bands of black, green, red. Who picked the correct resistor? (CBSE AI 2013C)
8. Define the term 'Mobility' of charge carriers in a conductor. Write its S.I. unit. (CBSE Delhi 2014, AI 2015)
9. How does the mobility of electrons in a conductor change, if the potential difference applied across the conductor is doubled, keeping the length and temperature of the conductor constant? (CBSE Delhi 2019)
10. Graph showing the variation of current versus voltage for a material GaAs is shown in the figure. Identify the region of
(i) negative resistance (ii) where Ohm's

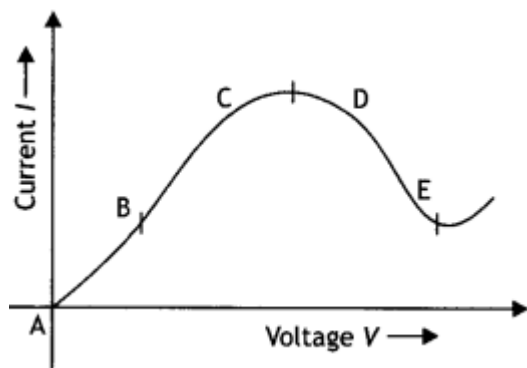

Short Questions:

1. Find the potential energy of this system. (CBSEAI, Delhi 2018)
2. The figure shows the $V - I$ graph for a parallel and series combination of two resistors A and B. Which line represents the parallel combination?

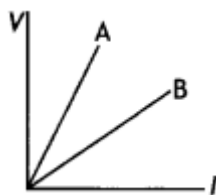

3. $V - I$ graph for a given metallic wire at two temperatures is shown. Which of these is at a higher temperature?

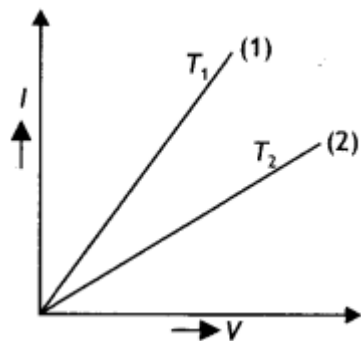

4. In an experiment on a metre bridge, if the balancing length AC is ' x ', what would be its value, when the radius of the metre bridge wire AB is doubled? Justify your answer. (CBSE AI 2011C)

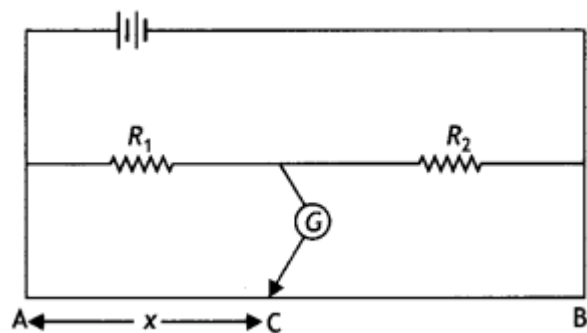

5. The emf of a cell is always greater than its terminal voltage. Why? Give reason. (CBSE Delhi 2013)

6. Draw a graph showing the variation of resistivity with temperature for nichrome. Which property of nichrome is used to make standard resistance coils? (CBSEAI 2013C)

7. Define the term 'mobility' for a charge carrier and state its SI unit.

Name the mobile charge carriers in

- (i) an electrolyte,
- (ii) a semiconductor and
- (iii) an ionised gas. (CBSE AI 2015)

8. Define the term current density of a metallic conductor. Deduce the relation connecting current density (J) and the conductivity (α) of the conductor, when an electric field E is applied to it. (CBSE AI 2015).

Long Questions:

1. Explain the term 'drift velocity' of electrons in a conductor. Hence obtain the expression for the current through a conductor in terms of 'drift velocity'. (CBSE AI 2013, 2013C)
2. Draw a plot showing the variation of resistivity of an (i) conductor and (ii) semiconductor, with the increase in temperature.

How does one explain this behaviour in terms of the number density of charge carriers and the relaxation time? (CBSE Delhi 2014C)

Assertion and Reason Questions-

1. For two statements are given-one labelled Assertion (A) and the other labelled Reason (R). Select the correct answer to these questions from the codes (a), (b), (c) and (d) as given below.

- a) Both A and R are true, and R is the correct explanation of A.
- b) Both A and R are true, but R is not the correct explanation of A.
- c) A is true, but R is false.
- d) A is false, and R is also false.

Assertion: The current in a wire is due to flow of free electrons in a definite direction.

Reason: A current carrying wire should have non-zero charge.

2. For two statements are given-one labelled Assertion (A) and the other labelled Reason (R). Select the correct answer to these questions from the codes (a), (b), (c) and (d) as given below.

- a) Both A and R are true, and R is the correct explanation of A.
- b) Both A and R are true, but R is not the correct explanation of A.
- c) A is true, but R is false.
- d) A is false, and R is also false.

Assertion: Though the same current flows through the live wires and the filament of the bulb but heat produced in the filament is much higher than that in live wires.

Reason: The filament of bulbs is made of a material of high resistance and high melting point.

Case Study Questions-

1. Whenever an electric current is passed through a conductor, it becomes hot after some time. The phenomenon of the production of heat in a resistor by the flow of an electric current through it is called heating effect of current or Joule heating. Thus, the electrical energy supplied by the source of emf is converted into heat. In purely resistive circuit, the energy expended by the source entirely appears as heat. But if the circuit has an active element like a motor, then a part of the energy supplied by the source goes to do useful work and the rest appears as heat. Joule's law of heating form the basis of various electrical appliances such as electric bulb, electric furnace, electric press etc.

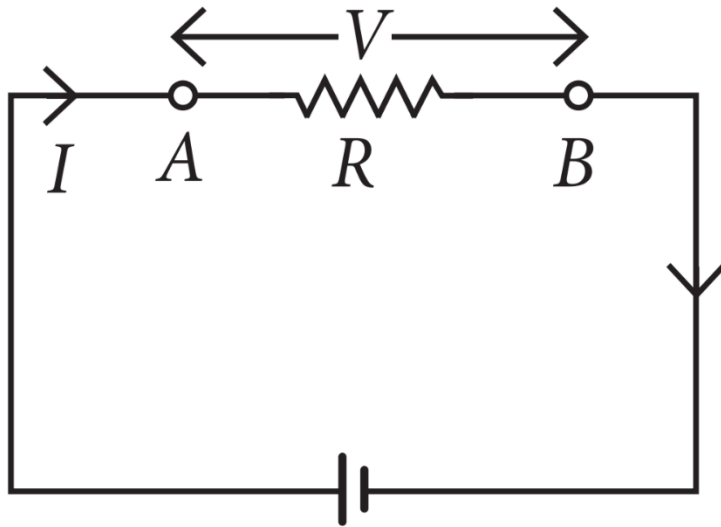

- (i) Which of the following is a correct statement?
- Heat produced in a conductor is independent of the current flowing.
 - Heat produced in a conductor varies inversely as the current flowing.
 - Heat produced in a conductor varies directly as the square of the current flowing.
 - Heat produced in a conductor varies inversely as the square of the current flowing.
- (ii) If the coil of a heater is cut to half, what would happen to heat produced?
- Doubled.
 - Halved.
 - Remains same.
 - Becomes four times.
- (iii) A 25W and 100W are joined in series and connected to the mains. Which bulbs will glow brighter?
- 100W.
 - 25W.

- c) Both bulbs will glow brighter.
 d) None will glow brighter.
- (iv) A rigid container with thermally insulated wall contains a coil of resistance 100Ω , carrying current $1A$. Change in its internal energy after 5 min will be:
- a) $0kJ$
 b) $10kJ$
 c) $20kJ$
 d) $30kJ$
- (v) The heat emitted by a bulb of $100W$ in 1 min is:
- a) $100J$
 b) $1000J$
 c) $600J$
 d) $6000J$

2. Potentiometer is an apparatus used for measuring the emf of a cell or potential difference between two points in an electrical circuit accurately. It is also used to determine the internal resistance of a primary cell. The potentiometer is based on the principle that, if V is the potential difference across any portion of the wire of length l and resistance R , then $V \propto l$ or $V = kl$ where k is the potential gradient. Thus, potential difference across any portion of potentiometer wire is directly proportional to length of the wire of that portion. The potentiometer wire must be uniform. The resistance of potentiometer wire should be high.

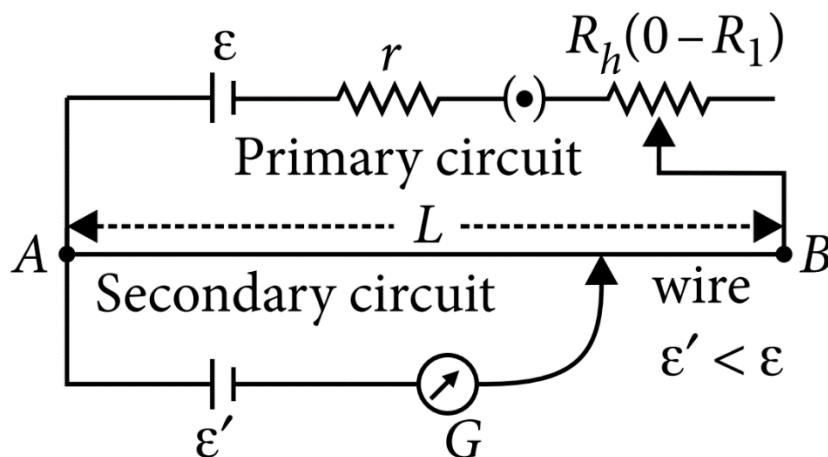

- (i) Which one of the following is true about potentiometer?
- a) Its sensitivity is low.
 b) It measures the emf of a cell very accurately.

- c) It is based on deflection method.
- d) None of the above.
- (ii) A current of 1.0mA is flowing through a potentiometer wire of length 4cm and of resistance 4Ω The potential gradient of the potentiometer wire is:
- a) 10^{-3}Vm^{-1}
- b) 10^{-5}Vm^{-2}
- c) $2 \times 10^{-3}\text{Vm}^{-1}$
- d) $4 \times 10^{-3}\text{Vm}^{-1}$
- (iii) Sensitivity of a potentiometer can be increased by:
- a) Decreasing potential gradient along the wire.
- b) Increasing potential gradient along the wire.
- c) Decreasing current through the wire.
- d) Increasing current through the wire.
- (iv) A potentiometer is an accurate and versatile device to make electrical measurements of EMF because the method involves:
- a) Potential gradients.
- b) A condition of no current flow through the galvanometer.
- c) A combination of cells, galvanometer and resistances.
- d) Cells.
- (v) In a potentiometer experiment, the balancing length is 8rn, when the two cells E_1 and E_2 are joined in series. When the two cells are connected in opposition the balancing length is 4m. The ratio of the e. m. f. of two cells $\left(\frac{E_1}{E_2}\right)$ is:
- a) 1 : 2
- b) 2 : 1
- c) 1 : 3
- d) 3 : 1

✓ **Answer Key:**

Multiple Choice Answers-

1. Answer: b
2. Answer: a

3. Answer: a
4. Answer: b
5. Answer: b
6. Answer: a
7. Answer: b
8. Answer: a
9. Answer: d
10. Answer: a

Very Short Answers:

1. Answer: The resistivity remains the same as it does not depend upon the length of the wire.
2. Answer: The relaxation time of electrons decreases with the rise in temperature of the metal.
3. Answer: It represents resistance. It is measured in ohm.
4. Answer: The mean velocity acquired by electrons in a conductor when an external electric field is applied to it.
5. Answer:

The required relation is $r = \left(\frac{\epsilon}{V} - 1\right)R$

6. Answer: It decreases.
7. Answer: A
8. Answer: Mobility of charge carriers in a conductor is defined as the magnitude of their drift velocity per unit applied electric field. Its SI unit is $\text{m}^2 \text{V}^{-1} \text{s}^{-1}$.
9. Answer: No change.
10. Answer: (i) DE (ii) AB

Short Questions Answers:

1. Answer: The potentiometer is based on the null method, or it does not draw any (net) current from the cell and measures emf. However, the voltmeter draws some current from the cell when connected across it, hence measures terminal voltage.
2. Answer: For the same potential, the current is less in series combination than parallel combination. Therefore, from the graph, it is apparent that the same potential current is less in A. Therefore, B represents the parallel combination.

$$\text{As, } R = \frac{V}{I}$$

The slope of B > Slope of A

3. Answer: At higher temperature resistance of a metallic wire is more or its conductance is low. Hence, graph (2) is at a higher temperature, i.e., $T_2 > T_1$.
4. Answer: In a metre bridge, at the balance point we have

$$\frac{R_1}{R_2} = \frac{x}{100-x}$$

As R_1 and R_2 remain the same, x will also remain the same. It does not depend upon the diameter of the wire.

5. Answer: When current passes through a cell, there is a drop in potential across it due to its internal resistance. This is called the lost volt. Thus, terminal voltage is less than the emf of the cell.
6. Answer: The graph is as shown.

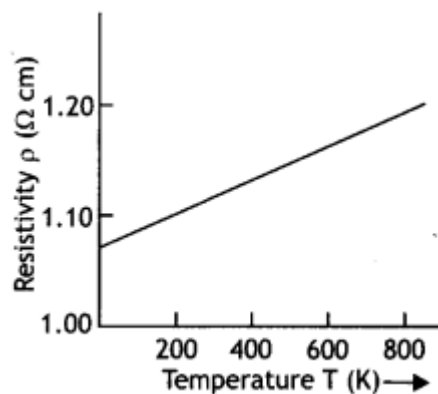

The property has a low-temperature coefficient of resistance.

7. Answer: Mobility is defined as the ratio of the drift velocity of the charge to the applied electric field.
 - (i) Anions and cations.
 - (ii) Electrons and holes
 - (iii) Free electrons.
8. Answer: Current density is defined as the current flowing per unit area of the conductor.

Mathematically current density is given by the expression $J = \frac{I}{A}$

But $I = V/R$ and $R = \frac{\rho l}{A} = \frac{L}{\sigma A}$. Substituting in the above relation, we have

$$J = \frac{I}{A} = \frac{V}{AL} \times \sigma A = \frac{V}{L} \times \sigma = E\sigma$$

Long Questions Answers:

1. Answer:

Drift velocity (V_d) is defined as the average velocity with which the free electrons get drifted inside a conductor under the effect of the electric field, opposite to the direction of the field.

Let n be the electrons per unit volume in the conductor. Here n is called the number density of electrons. Assume that all electrons move with the same drift velocity V_d . In a time interval dt , each electron moves a distance $v_d dt$. Now the volume of the cylinder covered by the electrons in time dt is

$$V = A v_d dt \dots (1)$$

and the number of electrons in this volume is

$$N = nV = nA v_d dt \dots (2)$$

If e is the charge on the electron, then charge flowing through the conductor in small time dt is

$$dQ = e(nA v_d dt) \dots (3)$$

Hence the current through the conductor is

$$I = \frac{dQ}{dt} = nA e v_d$$

2. Answer: The plots are as shown.

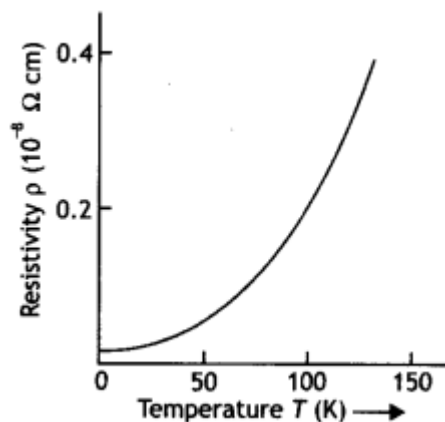

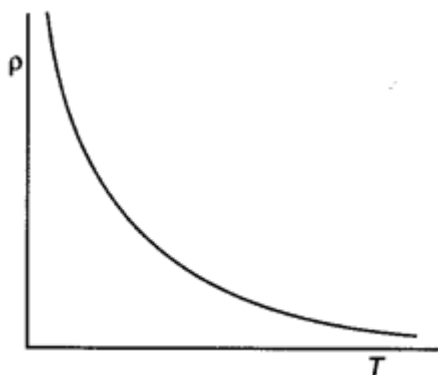

With a rise in temperature the average relaxation time for a conductor decreases and resistivity increases, while for a semiconductor the number density of charge carriers increases, hence the resistivity decreases.

Assertion and Reason Answers-

1. (c) A is true, but R is false.

Explanation:

The current in a wire is due to flow of free electrons in a definite direction. But the number of protons in the wire at any instant is equal to number of electrons and charge on electrons is equal and opposite to that of proton. Hence, net charge on the wire is zero.

2. (b) Both A and R are true, but R is not the correct explanation of A.

Explanation:

As filament of bulb and live wire are in series, hence current through both is same.

Now, because $H = \frac{i^2 R t}{4.2}$ and resistance of the filament of the bulb is much higher than that of live wires, hence heat produced in the filament is much higher than that in line wires.

Case Study Answers-

1. Answer :

(i) (c) Heat produced in a conductor varies directly as the square of the current flowing.

Explanation:

According to Joule's law of heating, Heat produced in a conductor, $H = I^2 R t$ where, $I =$ Current flowing through the conductor $R =$ Resistance of the conductor $t =$ Time for which current flows through the conductor.

$$\therefore H \propto I^2$$

(ii) (a) Doubled.

Explanation:

If the coil is cut into half, its resistance is also halved.

$$\text{As } H = \frac{V^2}{R} t$$

$$\therefore H' = 2$$

(iii) (b) 25W.

Explanation:

$$P = \frac{V^2}{R} \text{ or } R = \frac{V^2}{P}$$

The bulbs are joined in series. Current in both the bulbs will same.

\therefore The heat produced in them is given by $H = I^2 R t$

$$\text{or } H \propto R \Rightarrow H \propto \frac{1}{P}$$

Therefore the bulb with low wattage or high resistance will glow brighter or we can say the 25W bulb will glow brighter than the 100W bulb.

(iv) (d) 30kJ

Explanation:

$$R = 100\Omega; I = 1A; t = 5\text{min.} = 5 \times 60 = 300\text{s}$$

Change in internal energy = heat generated in coil

$$= I^2 R t = ((1)^2 \times 100 \times 300)\text{J}$$

$$= 30000\text{J} = 30\text{kJ.}$$

(v) (d) 6000J

Explanation:

Here, $P = 100\text{W}$, $t = 1\text{ min} = 60\text{s}$

Heat developed in time t

$$H = P \times t = (100\text{W})(60\text{s}) = 6000\text{J.}$$

2. Answer :

(i) (b) It measures the emf of a cell very accurately.

(ii) (a) 10^{-5}Vm^{-2}

Explanation:

Given, $I = 1.0\text{mA} = 10^{-3}\text{A}$;

$$R = 4\Omega; L = 4\text{m}$$

Potential drop across potentiometer wire,

$$V = IR = 10^{-3} \times 4\text{V}$$

$$\text{Potential gradient, } k = \frac{V}{L} = \frac{4 \times 10^{-3}}{4}$$

$$= 10^{-3}\text{Vm}^{-1}$$

- (iii) (a) Decreasing potential gradient along the wire.
 (iv) (b) A condition of no current flow through the galvanometer.

Explanation:

A potentiometer is an accurate and versatile device to make electrical measurements of EMF because the method involves a condition of no current flow through the galvanometer. It can be used to measure potential difference, internal resistance of a cell and compare EMF's of two sources.

- (v) (d) 3 : 1

Explanation:

$$\frac{E_1}{E_2} = \frac{l_1 + l_2}{l_1 - l_2} = \frac{8 + 4}{8 - 4}$$

$$= \frac{12}{4} = \frac{3}{1}$$



C V RAMAN
P U C O L L E G E
I N D I

CHAPTER 4: MOVING CHARGES AND MAGNETISM

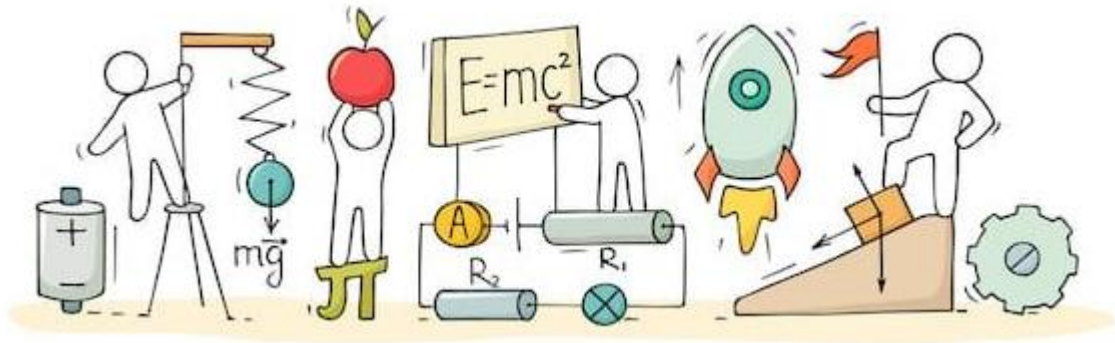

MOVING CHARGES AND MAGNETISM

Magnetic Field:

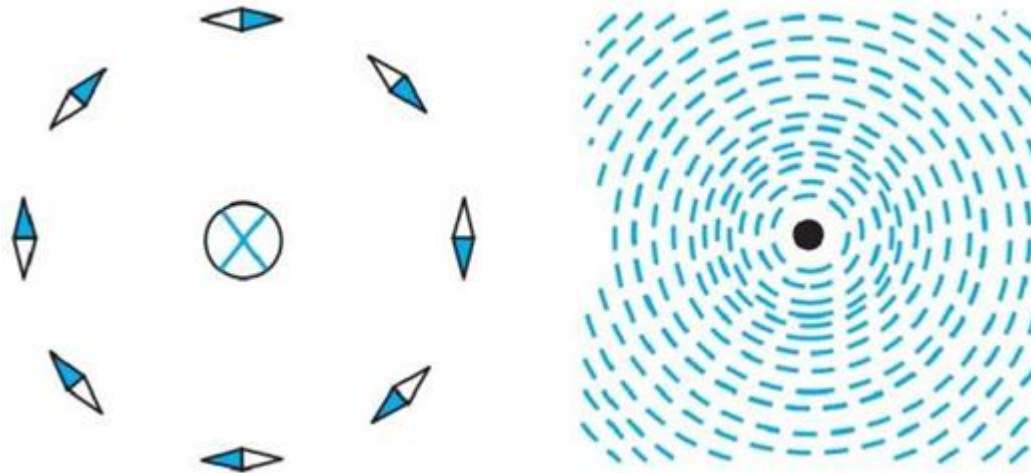

We have discussed that a stationary charge creates electric field in its surrounding space, similarly a moving charge creates a field in its surrounding space which exerts a force on a moving charge this field is known as magnetic field which is a vector quantity and represented by B .

Motion of charged particle in a Magnetic Field:

When a charged particle q is thrown in magnetic field \vec{B} with a velocity v then the force acting on the particle is given by $F = qvB \cdot \sin\theta$, where θ is the angle between the velocity and the magnetic field. As the magnetic force on a charged particle is perpendicular to the velocity, it does not do any work on the particle. Hence, the kinetic energy or the speed of the particle doesn't change due to the magnetic force.

Case I: $\theta = 0^\circ$ or 180°

Path followed: Straight line

If a charged particle is thrown parallel or antiparallel to magnetic field it does not experience any magnetic force as the angle θ between v and B will be zero or 180° . So, it will continue to move in a straight line with constant velocity.

Case II: $\theta = 90^\circ$

Path followed: Circular

When a charged particle is projected perpendicular to a uniform magnetic field, its path

is a circle. The magnetic Lorentz force acts as the centripetal force causing the charged particle to move in a circular path of radius R with constant speed.

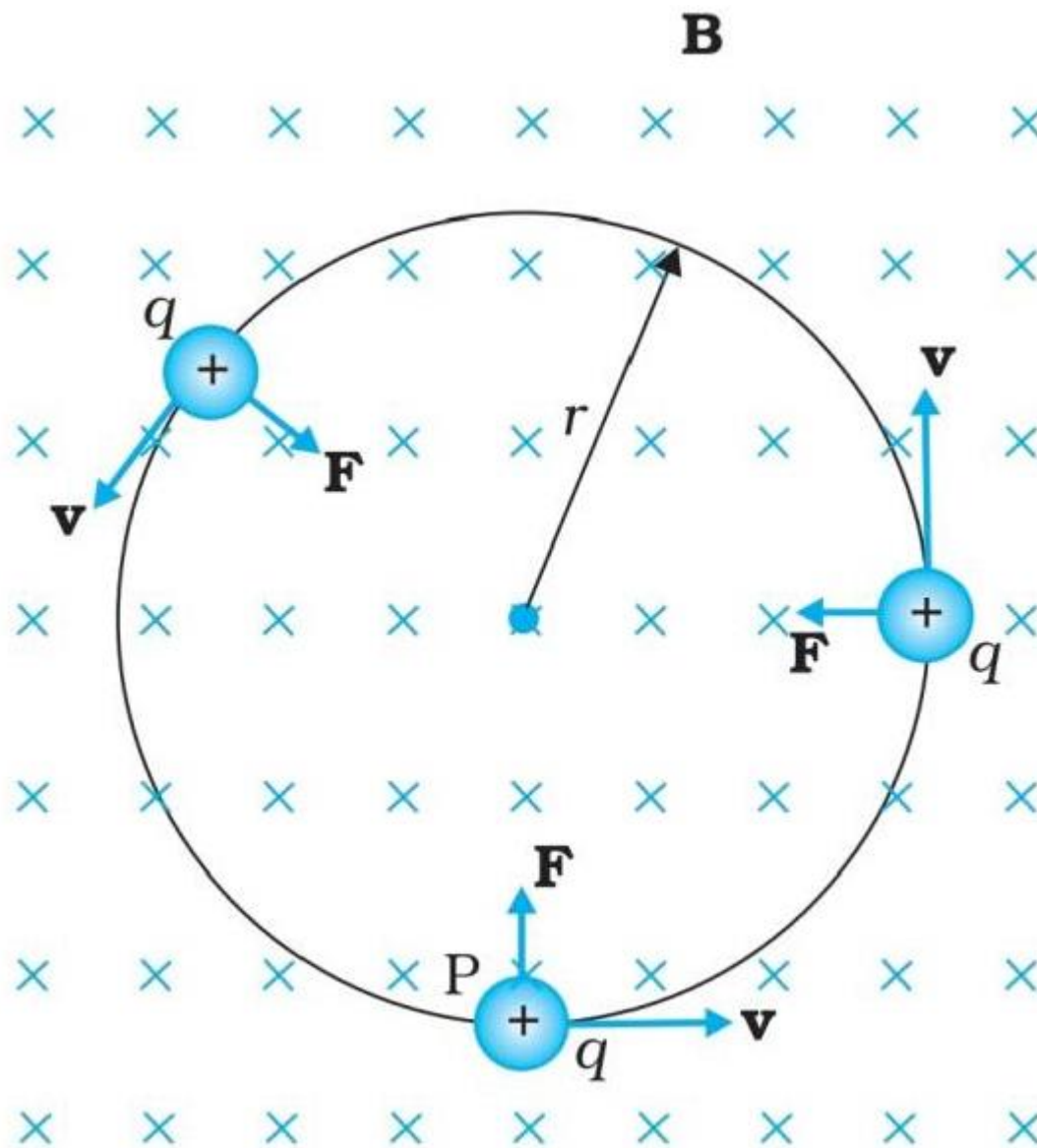

$$F = qvB = \frac{mv^2}{R}$$

$$\Rightarrow R = \frac{mv}{qB}$$

$$\text{Angular velocity}(\omega) = \frac{v}{R} = \frac{qB}{m}$$

$$\text{Time period of revolution } T = \frac{2\pi}{\omega} = \frac{2\pi m}{qB}$$

$$\text{Frequency of revolution} = \frac{1}{T} = \frac{qB}{2\pi m}$$

Biot-Savart Law:

Consider an infinitesimal element dl of the conductor. The magnetic field dB due to this element is to be determined at a point P which is at a distance r from it. Let θ be the angle between dl and the position vector r . The direction of dl is same as the direction of current.

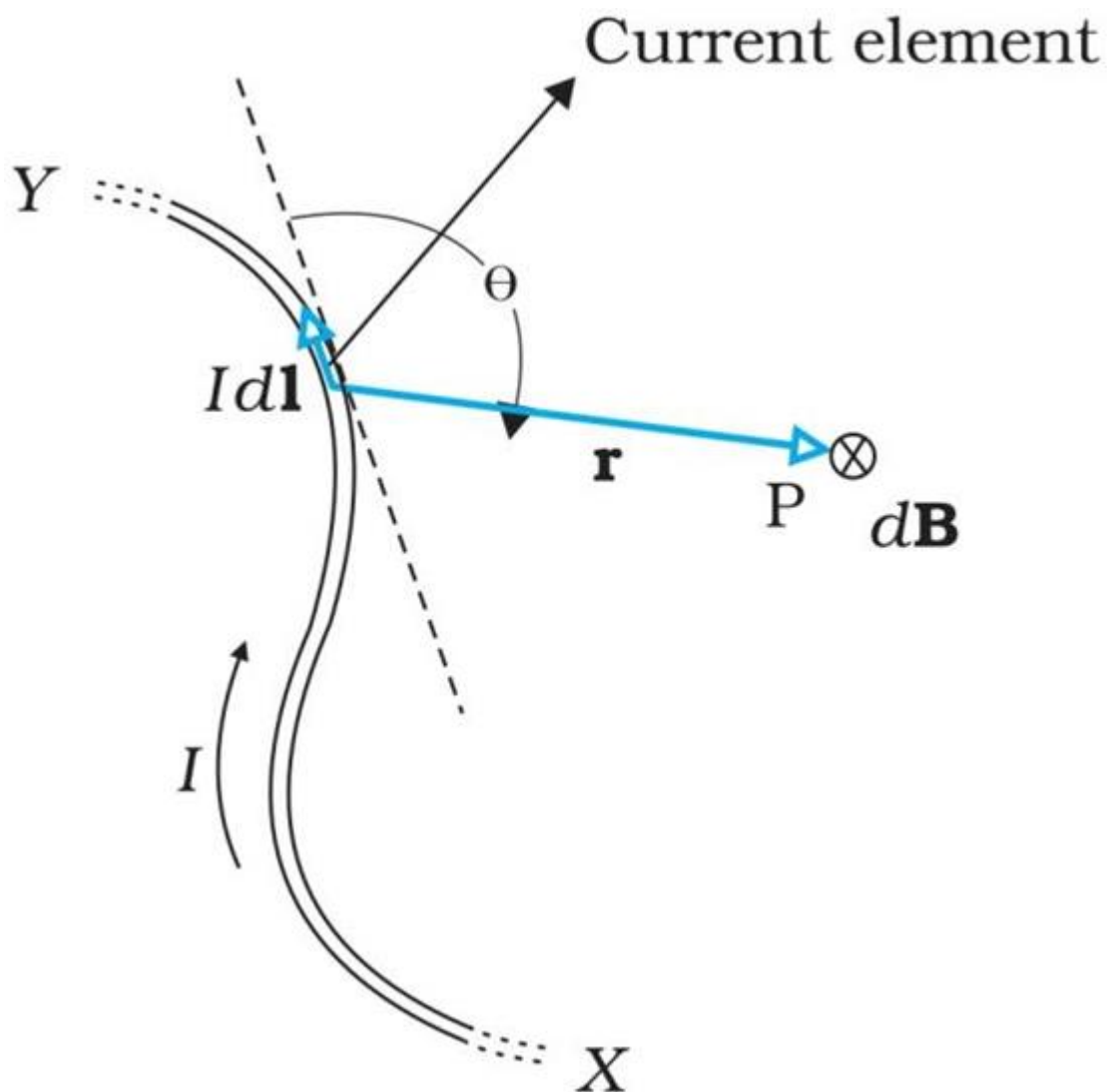

According to Biot-Savart law, the magnitude of the magnetic field dB is proportional to the current I , the element length dl is inversely proportional to the square of the distance r . Its direction is perpendicular to the plane containing dl and r . Thus in vector notation,

$$d\vec{B} \propto \frac{I d\vec{l} \sin\theta}{r^2}$$

$$d\vec{B} = \frac{\mu_0}{4\pi} \frac{I d\vec{l} \sin\theta}{r^2}$$

Where, $\frac{\mu_0}{4\pi}$ is a constant of proportionality. The above expression holds when the medium is vacuum. The proportionality constant in SI unit has value, $\frac{\mu_0}{4\pi} = 10^{-7} \text{T} \cdot \frac{\text{m}}{\text{A}}$. We call μ_0 the permeability of free space.

Magnetic Field due to a Loop of Current:

Magnetic field lines due to a loop of wire are shown in the figure. The direction of magnetic field on the axis of current loop can be determined by right hand thumb rule. If the fingers of right hand are curled in the direction of current, the stretched thumb is in the direction of magnetic field.

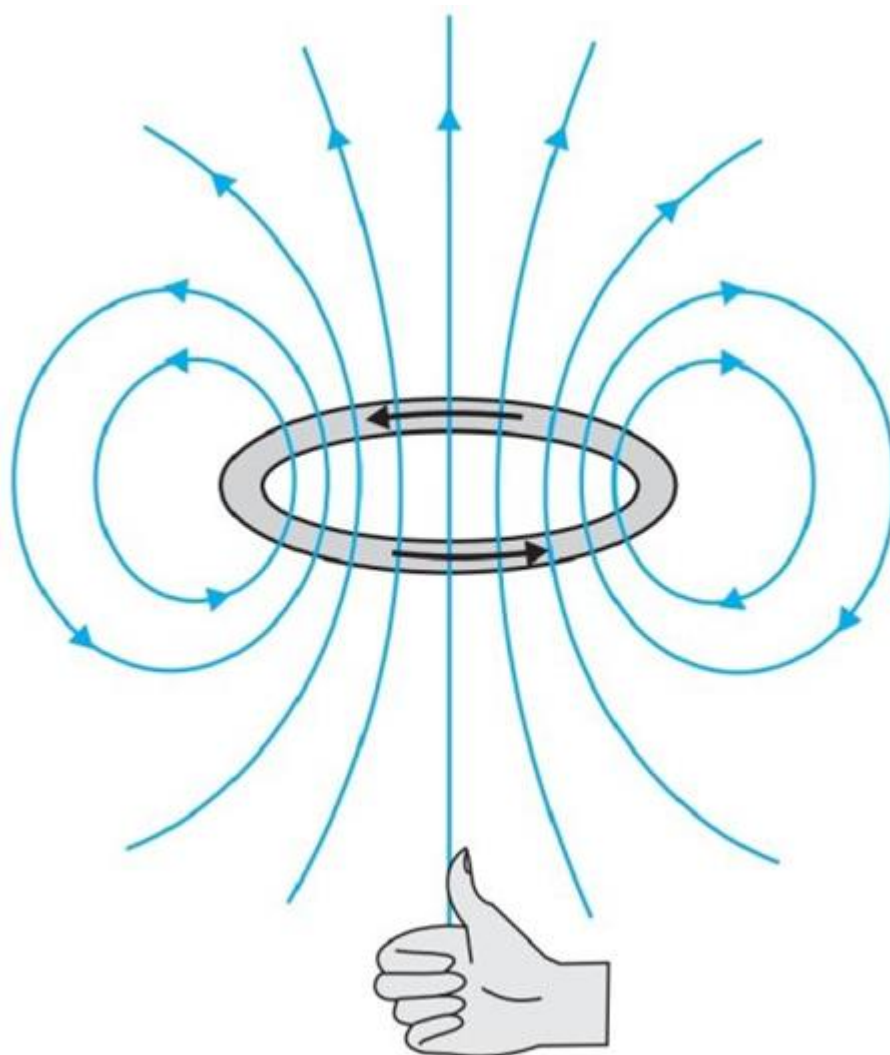

Consider a current loop placed in plane carrying current i in anticlockwise sense. Due to a small current element $i \cdot dl$ shown in the figure, the magnetic field is given by

$$dB = \frac{\mu_0}{4\pi} \frac{idl \cdot \sin 90}{r^2}$$

Strength of Magnetic Field at the center of loop,

$$\int dB = \int \frac{\mu_0 i dl \sin 90}{4\pi r^2}$$

$$B = \frac{\mu_0 i \sin 90}{4\pi r^2} \int dl$$

$$B = \frac{\mu_0 i}{4\pi r^2} 2\pi r$$

$$B = \frac{\mu_0 i}{2r}$$

If the loop has n round of wire,

$$B = \frac{\mu_0 ni}{2r}$$

Relation between μ_0 and ϵ_0

$$\frac{1}{4\pi\epsilon_0} = 9 \times 10^9 \dots (1)$$

$$\frac{\mu_0}{4\pi} = 10^{-7} \dots (2)$$

Dividing by eq. (2) to eq. (1)

$$\frac{\frac{\mu_0}{4\pi}}{\frac{1}{4\pi\epsilon_0}} = \frac{10^{-7}}{9 \times 10^9}$$

$$\frac{\mu_0}{4\pi} \times \frac{4\pi\epsilon_0}{1} = \frac{1}{9 \times 10^{9+7}}$$

$$\mu_0 \epsilon_0 = \frac{1}{(3 \times 10^8)^2}$$

$$\mu_0 \epsilon_0 = \frac{1}{c^2}$$

$$c = \frac{1}{\sqrt{\mu_0 \epsilon_0}}$$

Ampere's Circuital Law:

Ampere's circuital law states that line integral of steady magnetic field over a closed loop is equal to μ_0 times the total current (I_e) passing through the surface bounded by the loop i.e.,

$$\int B \cdot dl = \mu_0 I_e \text{ where } I_e \text{ is enclosed current}$$

Magnetic Force:

It is observed that when charge is at rest it experiences almost no force. However, if the charge q is given a velocity v in the direction of current, it is deflected towards the wire. Hence, we conclude that magnetic field exerts a force on a moving charge particle. The combination of electric and magnetic force on a point charge is known as Lorentz Force.

Consider a point charge q moving with velocity v located at position vector r at a given time t . If an electric field E and a magnetic field B exist at that point, then force on the electric charge q is given by

$$\vec{F} = q[\vec{E} + \vec{v} \times \vec{B}]$$

This force was first given by H. A. Lorentz; hence it is called Lorentz force.

Fleming's left-hand rule:

If we stretch the thumb and first two fingers of our left hand in mutually perpendicular directions such that forefinger points along B and middle finger points along v , then the thumb points along F .

Cyclone Frequency:

A charge c completes a circular orbit on a plane normal to B which is the uniform magnetic field. The uniform circular motion frequency is known as cyclone frequency. This frequency is unaffected by the radius and speed of the particle. It can be determined with the help of a machine known as cyclotron which is used to accelerate the particles which are charged.

Current Loop as a Magnetic Dipole:

A current carrying loop behaves like a magnetic dipole. It has two poles viz north and south like that of a bar magnet. Following figures show magnetic field lines due to a bar magnet and a current carrying loop.

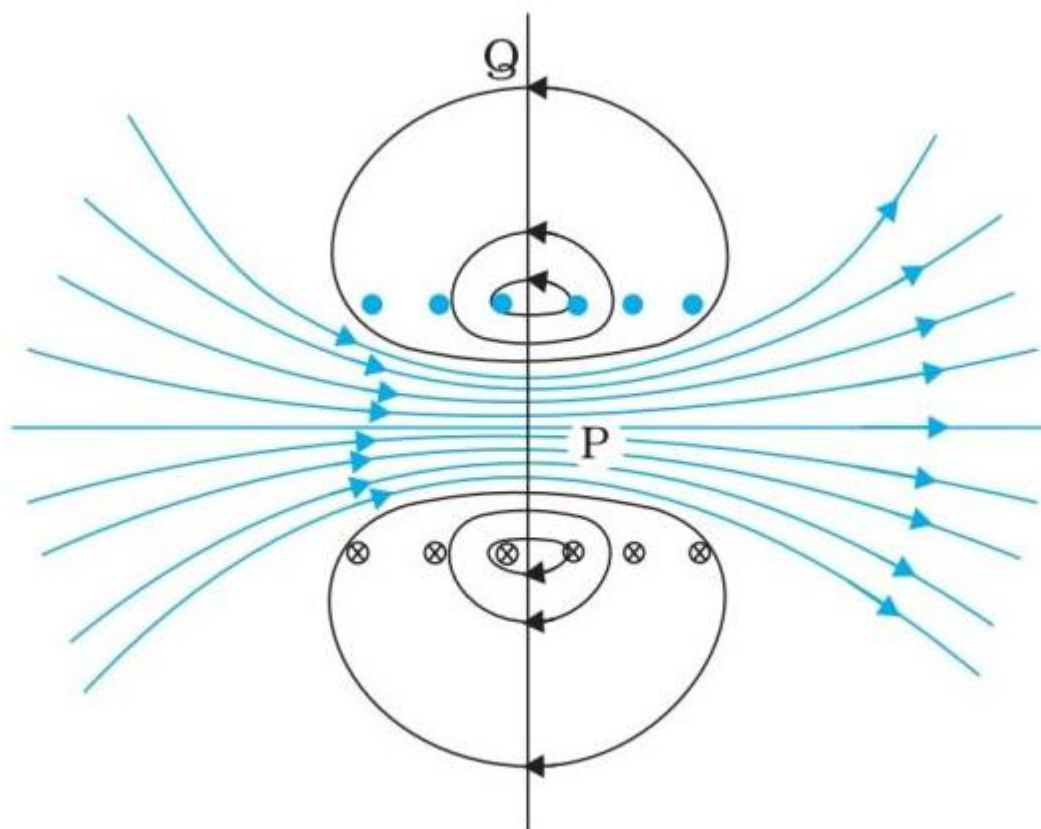

The magnetic dipole moment vector for a current loop is given by

$$\vec{M} = Ni\vec{A},$$

where, N = number of loops or turns

i = current through each turn

A = area of each turn

Current sensitivity: It is defined as the deflection produced per unit current passed through the galvanometer.

Voltage sensitivity: It is defined as the deflection produced per unit voltage applied across the galvanometer.

Galvanometer as Ammeter:

The galvanometer cannot as such be used as an ammeter to measure the value of the current in a given circuit. This is for two reasons.

- Galvanometer is a very sensitive device. It gives a full-scale deflection for a current of the order of μA .
- For measuring currents, the galvanometer has to be connected in series, and as it has a large resistance, this will change the value of the current in the circuit.

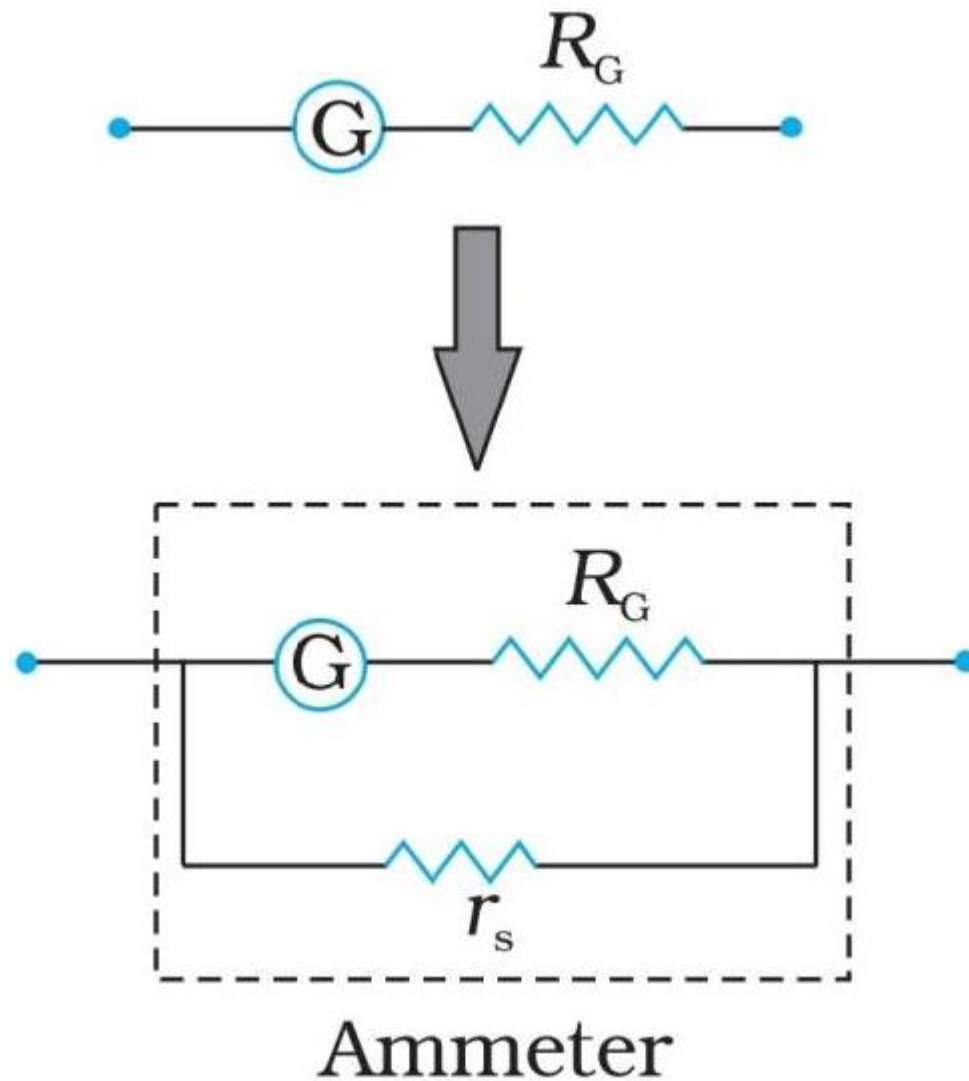

To overcome these difficulties, one attaches a small resistance r_s called shunt resistance, in parallel with the galvanometer coil, so that most of the current passes through the shunt. The resistance of this arrangement is.

$$\frac{R_G r_s}{R_G + r_s} = r_s$$

We define the current sensitivity of the galvanometer as the deflection per unit current. Thus

$$\frac{\theta}{i} = \frac{NAB}{K}$$

Galvanometer as Voltmeter:

To use galvanometer to find the potential difference between a section of a circuit, it must be connected in parallel to that section of the circuit. Further, it must draw very small current, otherwise the voltage measurement will disturb the original setup by an amount which is very large. Usually, we like to keep the disturbance due to the measuring device below one percent. To ensure this, a large resistance R is connected in series with the galvanometer.

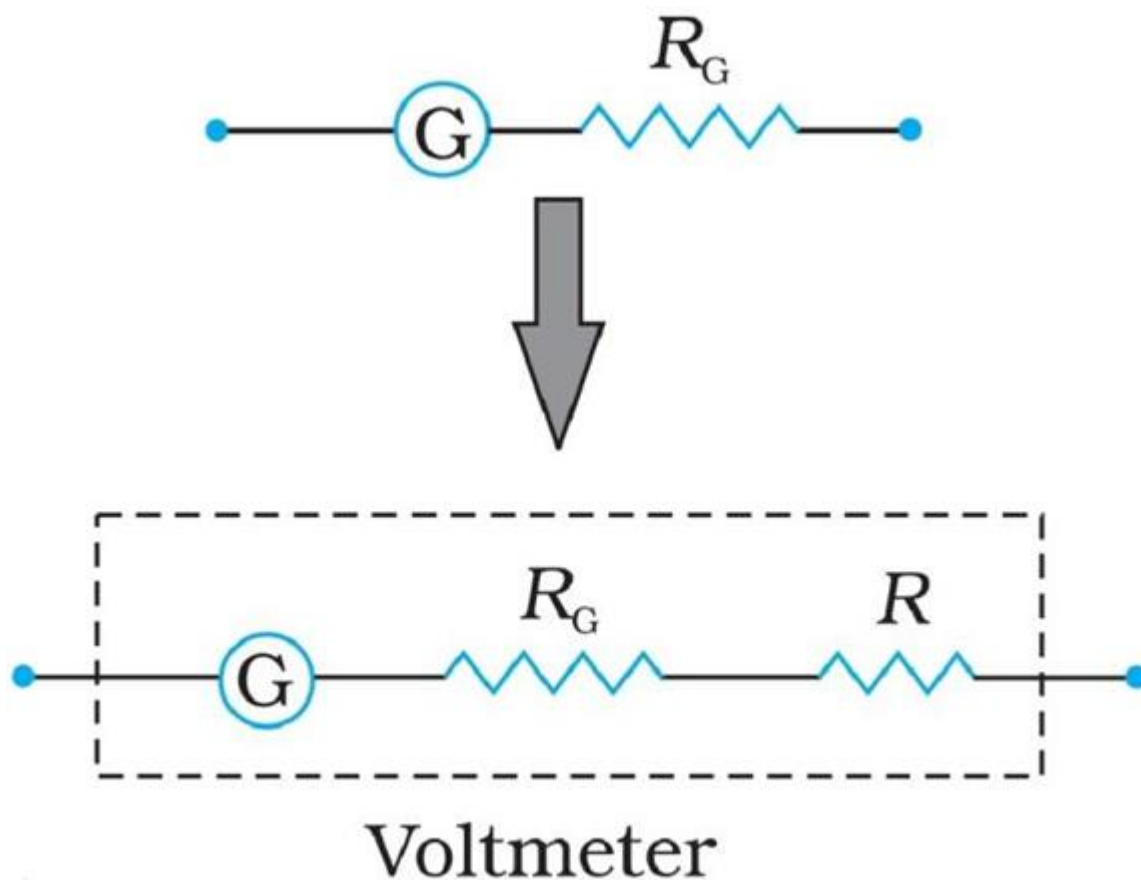

We define voltage sensitivity as the deflection per unit voltage.

$$\frac{\theta}{V} = \left(\frac{NAB}{K} \right) \frac{i}{V}$$

Class : 12th Physics
Chapter- 4 : Moving Charges and Magnetism

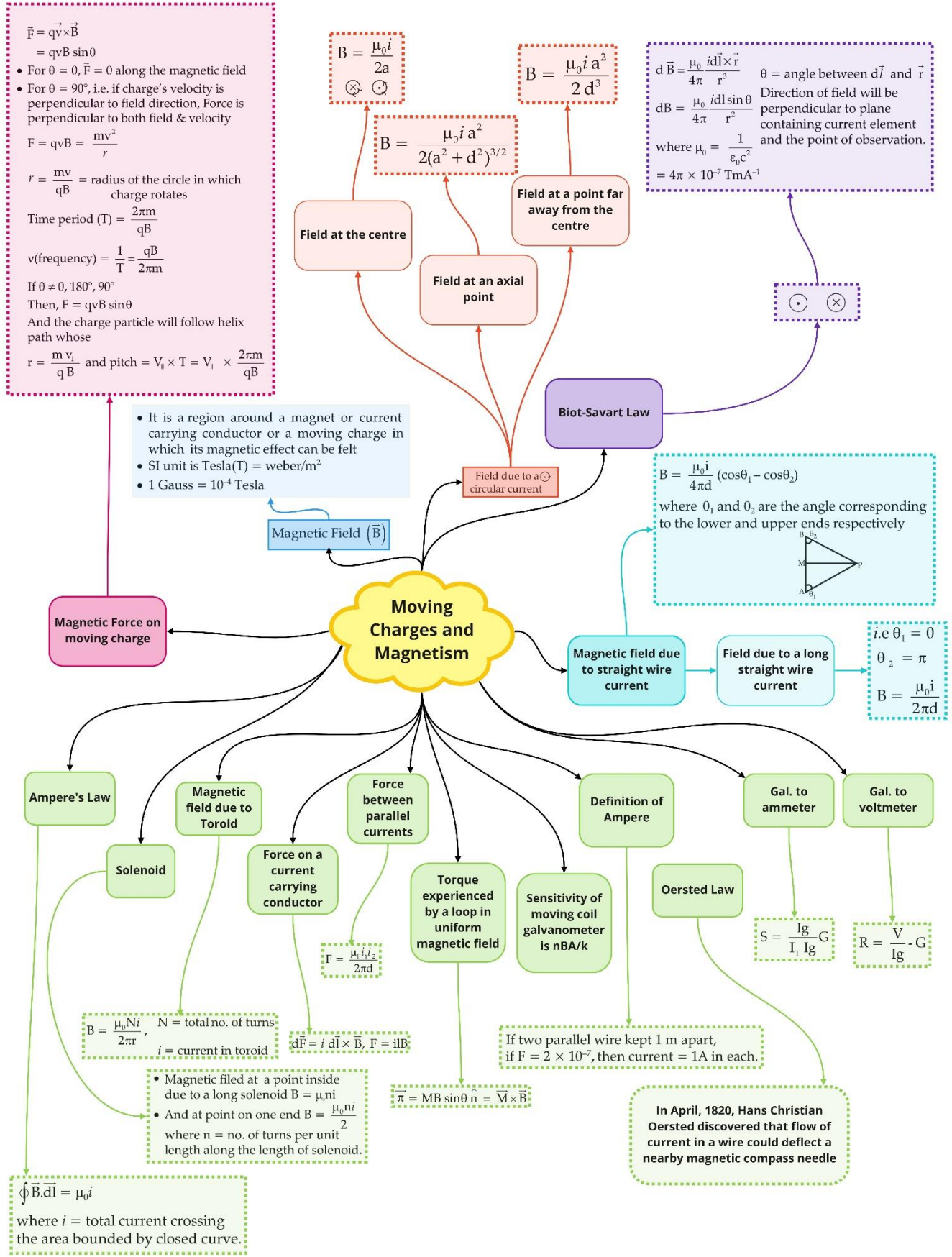

Important Questions

Multiple Choice questions-

1. A charged particle is moving in a cyclotron, what effect on the radius of path of this charged particle will occur when the frequency of the radio frequency field is doubled?

- (a) It will also be doubled.
- (b) It will be halved.
- (c) It will be increased by four times.
- (d) It will remain unchanged.

2. Which of the following is not correct about cyclotron?

- (a) It is a machine to accelerate charged particles or ions to high energies.
- (b) Cyclotron uses both electric and magnetic fields in combination to increase the energy of charged particles.
- (c) The operation of the cyclotron is based on the fact that the time for one revolution of an ion is independent of its speed or radius of its orbit.
- (d) The charged particles and ions in cyclotron can move on any arbitrary path.

3. If an electron is moving with velocity \vec{v} produces a magnetic field \vec{B} , then

- (a) the direction of field \vec{B} will be same as the direction of velocity \vec{v} .
- (b) the direction of field \vec{B} will be opposite to the direction of velocity \vec{v} .
- (c) the direction of field \vec{B} will be perpendicular to the direction of velocity \vec{v} .
- (d) the direction of field \vec{B} does not depend upon the direction of velocity \vec{v} .

4. Current flows through uniform, square frames as shown in the figure. In which case is the magnetic field at the center of the frame not zero?

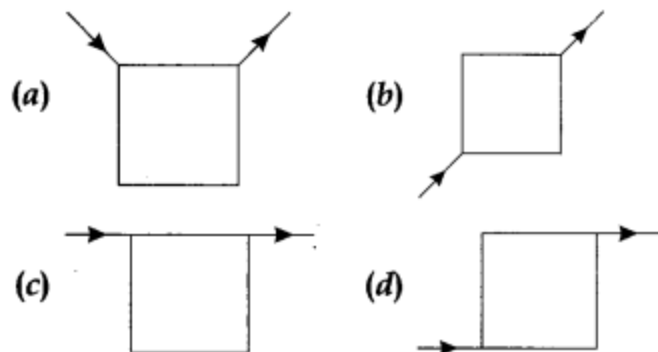

5. Ampere's circuital law is given by

(a) $\oint \vec{H} \cdot d\vec{l} = \mu_0 I_{\text{enc}}$ (b) $\oint \vec{B} \cdot d\vec{l} = \mu_0 I_{\text{enc}}$

(c) $\oint \vec{B} \cdot d\vec{l} = \mu_0 J$ (d) $\oint \vec{H} \cdot d\vec{l} = \mu_0 J$

6. Two identical current carrying coaxial loops, carry current I in opposite sense. A simple amperian loop passes through both of them once. Calling the loop as C , then which statement is correct?

(a) $\oint_C \vec{B} \cdot d\vec{l} = \pm 2\mu_0 I$

(b) the value of $\oint_C \vec{B} \cdot d\vec{l}$ is independent of sense of C .

(c) there may be a point on C where B and $d\vec{l}$ are parallel.

(d) none of these

7. The correct plot of the magnitude of magnetic field B vs distance r from centre of the wire is, if the radius of wire is R

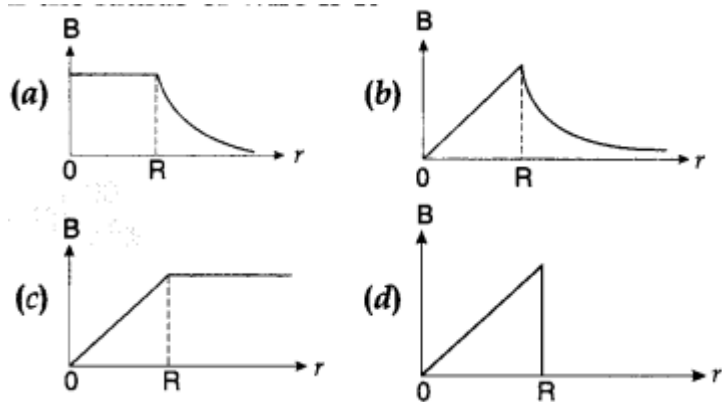

8. The nature of parallel and anti-parallel currents are

(a) parallel currents repel and antiparallel currents attract.

(b) parallel currents attract and antiparallel currents repel.

(c) both currents attract.

(d) both currents repel.

9. The magnetic moment of a current I carrying circular coil of radius r and number of turns N varies as

(a) $\frac{1}{r^2}$

(b) $\frac{1}{r}$

(c) r

(d) r^2

10. A short bar magnet has a magnetic moment of 0.65 J T^{-1} , then the magnitude and direction of the magnetic field produced by the magnet at a distance 8 cm from the center of magnet on the axis is

- (a) $2.5 \times 10^{-4} \text{ T}$, along NS direction
- (b) $2.5 \times 10^{-4} \text{ T}$ along SN direction
- (c) $4.5 \times 10^{-4} \text{ T}$, along NS direction
- (d) $4.5 \times 10^{-4} \text{ T}$, along SN direction

Very Short:

1. Under what condition is the force acting on a charge moving through a uniform magnetic field minimum?
2. What is the nature of the magnetic field in a moving coil galvanometer?
3. State two properties of the material of the wire used for suspension of the coil in a moving coil galvanometer.
4. Write one condition under which an electric charge does not experience a force in a magnetic field.
5. Mention the two characteristic properties of the material suitable for making the core of a transformer. (CBSE AI 2012)
6. Write the expression, in a vector form, for the Lorentz magnetic force due to a charge moving with velocity \vec{V} in a magnetic field \vec{B} . What is the direction of the magnetic force? (CBSE Delhi 2014)
7. Write the condition under which an electron will move undeflected in the presence of crossed electric and magnetic fields. (CBSE AI 2014C)
8. What can be the cause of the helical motion of a charged particle? (CBSE AI 2016)
9. Write the underlying principle of a moving coil galvanometer. (CBSE Delhi 2016)
10. A proton and an electron traveling along parallel paths enter a region of the uniform magnetic field, acting perpendicular to their paths. Which of them will move in a circular path with a higher frequency? (CBSEAI and Delhi 2018)

Short Questions:

1. A charged particle having a charge q is moving with a speed of v along the X-axis. It enters a region of space where the electric field is \vec{E} ($E\hat{j}$) and a magnetic field \vec{B} are both present. The particle, on emerging from the region, is observed to be moving, along the X-axis only. Obtain an expression for the magnitude of \vec{B} in terms of v and E . Give the direction of \vec{B} .

2. A stream of electrons traveling with speed v m s⁻¹ at right angles to a uniform magnetic field 'B' is reflected in a circular path of radius 'r'.

Prove that $\frac{e}{m} = \frac{v}{rB}$

3. Which one of the two, an ammeter or a milliammeter, has a higher resistance and why?

4. A straight wire of length L carrying a current I stay suspended horizontally in mid-air in a region where there is a uniform magnetic field \vec{B} . The linear mass density of the wire is λ . Obtain the magnitude and direction of the magnetic field.

5. In the figure below, the straight wire AB is fixed while the loop is free to move under the influence of the electric currents flowing in them. In which direction does the loop begin to move? Give a reason for your

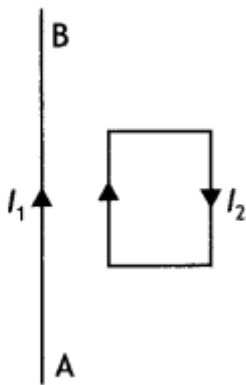

6. A coil of 'N' turns, and radius 'R' carries a current 'I'. It is unwound and rewound to make a square coil of side 'a' having the same number of turns (N). Keeping the current 'I' same, find the ratio of the magnetic moments of the square coil and the circular coil. (CBSE Delhi 2013C)

7. Write the expression for Lorentz magnetic force on a particle of charge 'q' moving with velocity v in a magnetic field B . Show that no work is done by this force on the charged particle. (CBSE AI 2011)

8. (a) State Biot-Savart law in vector form expressing the magnetic field due to an element \vec{dl} carrying current I at a distance \vec{r} from the element.

Long Questions:

1.

(a) A particle of charge 'q' and mass 'm', moving with velocity \vec{v} is subjected to a uniform magnetic field \vec{B} perpendicular to its velocity. Show that the particle describes a circular path. Obtain an expression for the radius of the circular path of the particle.

(b) Explain, how its path will be affected if the velocity \vec{v} makes an angle ($\theta \neq 90^\circ$) with

the direction of the magnetic field. (CBSE 2019C)

2.

(a) Obtain the conditions under which an electron does not suffer any deflection while passing through a magnetic field.

(b) Two protons P and Q moving with the same speed pass through the magnetic fields \vec{B}_1 and \vec{B}_2 respectively, at right angles to the field directions. If $|\vec{B}_2| > |\vec{B}_1|$, which of the two protons will describe the circular path of smaller radius? Explain. (CBSEAI 2019)

Assertion and Reason Questions-

1. Two statements are given-one labelled Assertion (A) and the other labelled Reason (R). Select the correct answer to these questions from the codes (a), (b), (c) and (d) as given below.

- a) Both A and R are true and R is the correct explanation of A.
- b) Both A and R are true but R is NOT the correct explanation of A.
- c) A is true but R is false.
- d) A is false and R is also false.

Assertion (A): A charge, whether stationary or in motion produces a magnetic field around it.

Reason (R): Moving charges produce only electric field in the surrounding space.

2. Two statements are given-one labelled Assertion (A) and the other labelled Reason (R). Select the correct answer to these questions from the codes (a), (b), (c) and (d) as given below.

- a) Both A and R are true and R is the correct explanation of A.
- b) Both A and R are true but R is NOT the correct explanation of A.
- c) A is true but R is false.
- d) A is false and R is also false.

Assertion (A): A charged particle moving in a uniform magnetic field penetrates a layer of lead and there by loses half of its kinetic energy. The radius of curvature of its path is now reduced to half of its initial value.

Reason (R): Kinetic energy is inversely proportional to radius of curvature.

Case Study Questions-

1. A charged particle moving in a magnetic field experiences a force that is proportional to the strength of the magnetic field, the component of the velocity that is perpendicular to the magnetic field and the charge of the particle.

This force is given by $\vec{F} = q(\vec{v} \times \vec{B})$ where q is the electric charge of the particle, v is the instantaneous velocity of the particle, and B is the magnetic field (in tesla).

The direction of force is determined by the rules of cross product of two vectors.

Force is perpendicular to both velocity and magnetic field. Its direction is same as $\vec{v} \times \vec{B}$ if q is positive and opposite of $\vec{v} \times \vec{B}$ if q is negative.

The force is always perpendicular to both the velocity of the particle and the magnetic field that created it. Because the magnetic force is always perpendicular to the motion, the magnetic field can do no work on an isolated charge. It can only do work indirectly, via the electric field generated by a changing magnetic field.

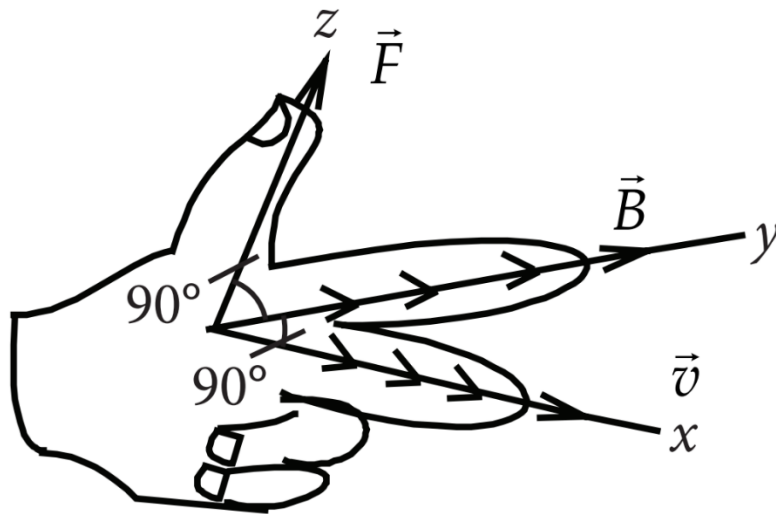

- (i) When a magnetic field is applied on a stationary electron, it:
 - a) Remains stationary.
 - b) Spins about its own axis.
 - c) Moves in the direction of the field.
 - d) Moves perpendicular to the direction of the field.
- (ii) A proton is projected with a uniform velocity v along the axis of a current carrying solenoid, then,
 - a) The proton will be accelerated along the axis.
 - b) The proton path will be circular about the axis.
 - c) The proton moves along helical path.
 - d) The proton will continue to move with velocity v along the axis.
- (iii) A charged particle experiences magnetic force in the presence of magnetic field. Which of the following statement is correct?
 - a) The particle is stationary and magnetic field is perpendicular.

- b) The particle is moving and magnetic field is perpendicular to the velocity.
 c) The particle is stationary and magnetic field is parallel.
 d) The particle is moving and magnetic field is parallel to velocity.
- (iv) A charge q moves with a velocity 2m s^{-1} along x-axis in a uniform magnetic field $\vec{F} = (\vec{i} + 2\vec{j} + 3\vec{k})\text{T}$, charge will experience a force.
- a) In z-y plane.
 b) Along -y axis.
 c) Along +z axis.
 d) Along -z axis.
- (v) Moving charge will produce.
- a) Electric field only.
 b) Magnetic field only.
 c) Both electric and magnetic field.
 d) None of these.

2. A galvanometer can be converted into voltmeter of given range by connecting a suitable resistance R , in series with the galvanometer, whose value is given by,

$$R_s = \frac{V}{I_g} - G$$

where V is the voltage to be measured, I_g is the current for full scale deflection of galvanometer and G is the resistance of galvanometer.

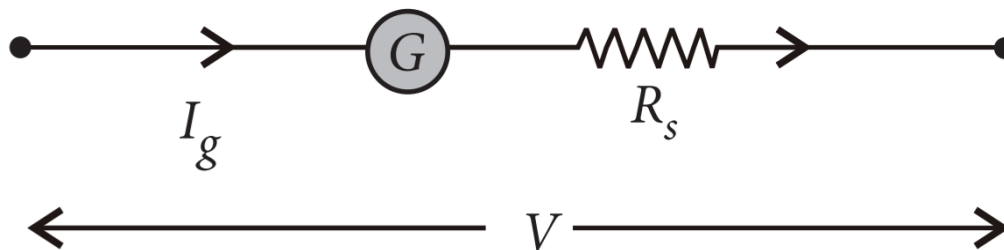

Series resistor (R_s) increases range of voltmeter and the effective resistance of galvanometer. It also protects the galvanometer from damage due to large current. Voltmeter is a high resistance instrument and it is always connected in parallel with the circuit element across which potential difference is to be measured. An ideal voltmeter has infinite resistance. In order to increase the range of voltmeter n times the value of resistance to be connected in series with galvanometer is $R_s = (n - 1)G$.

- (i) 10mA current can pass through a galvanometer of resistance 25Ω What resistance in series should be connected through it, so that it is converted into a voltmeter of 100V?
- 0.975Ω
 - 99.75Ω
 - 975Ω
 - 9975Ω
- (ii) There are 3 voltmeter A, B, C having the same range but their resistance are 15000Ω , 10000Ω and 5000Ω respectively. 'Tile best voltmeter amongst them is the one whose resistance is
- 5000Ω
 - 10000Ω
 - 15000Ω
 - all are equally good.
- (iii) A milliammeter of range 0 to 25mA and resistance of 10Ω is to be converted into a voltmeter with a range of 0 to 25V. 'Tile resistance that should be connected in series will be:
- 930Ω
 - 960Ω
 - 990Ω
 - 1010Ω
- (iv) To convert a moving coil galvanometer (MCG) into a voltmeter:
- A high resistance R is connected in parallel with MCG.
 - A low resistance R is connected in parallel with MCG.
 - A low resistance R is connected in series with MCG.
 - A high resistance R is connected in series with MCG.
- (v) To increase the current sensitivity of a moving coil galvanometer, we should decrease:
- Zero.

- b. Low.
- c. High.
- d. Infinity.

✓ Answer Key:

Multiple Choice Answers-

1. Answer: d
2. Answer: d
3. Answer: c
4. Answer: c
5. Answer: b
6. Answer: b
7. Answer: b
8. Answer: b
9. Answer: d
10. Answer: b

Very Short Answers:

1. Answer: When the charge moves parallel to the direction of the magnetic field.
2. Answer: Radial magnetic field.
3. Answer:
 - High tensile strength.
 - Small value of torque per unit twist.
4. Answer: When it moves parallel to the direction of the magnetic field.
5. Answer:
 - Low retentivity
 - High permeability
6. Answer: The expression is $\vec{F} = q(\vec{V} \times \vec{B})$. The force is perpendicular to both the velocity and the magnetic field vector.
7. Answer: An electron moves perpendicular to both fields.
8. Answer: The charge enters the magnetic field at any angle except 0° , 180° , and

90°.

9. Answer: A current-carrying loop placed in a magnetic field experiences a torque.

10. Answer:

The frequency of revolution is given by

$$v = \frac{Bq}{2\pi m} \Rightarrow v \propto \frac{1}{m}$$

As for $m_e < m_p$

therefore $v_e > v_p$

Short Questions Answers:

1. Answer: Since the particle continues to move along the X-axis, therefore, the magnetic force acting on it should be completely balanced by the electric force. Since the electric force acts along the Y-axis, therefore, the magnetic force must be along the Z-axis.

Thus, in equilibrium $qE = Bqv$ or $v = E/B$

2. Answer: Let a stream of electrons be traveling with speed v at right angles to a uniform magnetic field B then force due to magnetic field provides the required centripetal force which deflects the electron beam along a circular path of radius ' r ' such that

$$Bev = \frac{mv^2}{r}$$

or

$$\frac{e}{m} = \frac{v}{rB}$$

where e = electronic charge and m = mass of the electron.

3. Answer:

The shunt resistance connected to convert a galvanometer into an ammeter or a milliammeter is given by the expression $S = \frac{I_g G}{I - I_g}$ where S is shunt resistance, G galvanometer resistance, I total current through G and S , and I_g galvanometer current. In the case of milliammeter, I is small.

Therefore $S_{\text{milliammeter}} > S_{\text{ammeter}}$. Hence the resistance of a milliammeter is greater than that of an ammeter.

4. Answer: The magnetic force acting on the straight wire balances the weight of the wire.

Therefore, in equilibrium we have $Mg = BIL$, here $M = LI$, therefore we have $LIg = BIL$ or $B = I/g$

This field acts vertically upwards.

5. Answer: The loop moves towards the straight wire AB. In the loop in the side nearer to the wire AB current I_2 is in the same direction as I_1 and hence attractive force acts. However, on the side farther away from the wire AB current I_2 is in the opposite direction and the force is repulsive. But as the magnitude of attractive force is greater than the repulsive force, the net force is attractive in nature and hence, the loop moves towards the wire AB.
6. Answer:

The magnetic moment of a current loop is given by the relation $M = nIA$

For the circular loop $M_C = NI\pi R^2 \dots(1)$

Now when the coil is unwound and rewound to make a square coil, then

$$2\pi R = 4a \text{ or } a = \pi R/2$$

Hence magnetic moment of the square coil is

$$M_S = NI a^2 = NI (\pi R/2)^2 = NI \pi^2 R^2/4 \dots(2)$$

From (1) and (2) we have

$$\frac{M_S}{M_C} = \frac{NI\pi^2 R^2/4}{NI\pi R^2} = \frac{\pi}{4}$$

7. Answer:

The expression is $\vec{F} = q(\vec{v} \times \vec{B})$. This force always acts perpendicular to the direction of motion of the charged particle. Therefore the angle between \vec{F} and \vec{r} is 90° . Hence work done is $W = \vec{F} \cdot \vec{r} = Fr \cos 90^\circ = 0$

8. Answer:

(a) It states that for a small current element dL the magnetic field at a distance r is given by

$$\vec{dB} = \frac{\mu_0}{4\pi} \frac{I(d\vec{L} \times \hat{r})}{r^2}$$

(b) The magnetic field at the centre of a circular loop is given by

$$B = \frac{\mu_0 I}{2r}$$

The field lines are as shown.

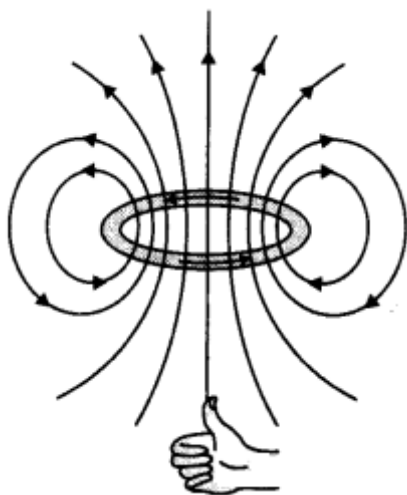

Long Questions Answers:

1. Answer:

(a) Let a charged particle of charge q and mass m be moving with velocity \vec{v} right angle to the field (i.e., in the plane of the paper), then magnetic force \vec{F} acting on the charge q will be

$$\vec{F} = q(\vec{v} \times \vec{B})$$

or

$$F = qvB \sin 90^\circ$$

or

$$F = qvB \dots (1)$$

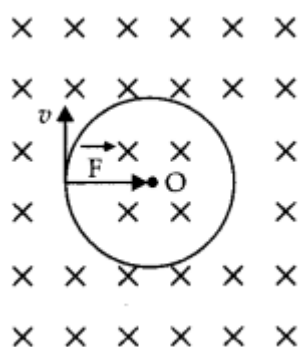

As this forces fact at a right angle to the velocity V of the charged particle, the slot is unable to change the velocity but can make the charged particle move In a circular path.

If r is the radius of the circle, then the centripetal force required by the charged particle will be

$$F_c = \frac{mv^2}{r}$$

This centripetal force Is provided by the magnetic force acting on the charged particle.

$$\begin{aligned} \text{i.e.} \quad & F_c = F \\ \text{or} \quad & \frac{mv^2}{r} = qvB \\ \text{or} \quad & r = \frac{mv}{qB} \end{aligned}$$

(b) If ($\theta \neq 90^\circ$), the velocity \vec{v} of the moving charge can be resolved into two components $v \cos \theta$, in the direction of the magnetic field and $v \sin \theta$, in the direction perpendicular to the magnetic field. The charged particle under the combined effect of the two components of velocities will cover linear as well as a circular path, i.e., helical path whose axis is parallel to the magnetic field.

2. Answer:

(a) No deflection suffered by the electron if it moves parallel or anti-parallel to the magnetic field.

(b) The radius of the circular path travelled by a charged particle in a magnetic field is given by

$$r = \frac{mv}{Bq}$$

$$\text{Therefore, } \frac{r_1}{r_2} = \frac{B_2}{B_1}$$

As $|\vec{B}_2| > |\vec{B}_1|$ therefore, $r_2 < r_1$ **Assertion and Reason Answers-**

1. (d) A is false and R is also false.

Explanation:

A charge, whether stationary or in motion, produces an electric field around it. If it is in motion, then in addition to the electric field, it also produces a magnetic field, because moving charges produce magnetic field in the surrounding space.

2. (b) Both A and R are true but R is NOT the correct explanation of A.

Explanation:

The radius of curvature of a charged particle in a magnetic field is given by,

$$r = \frac{mv}{qB} = \frac{\sqrt{2mK.E.}}{qB} \text{ i.e. } r \propto \sqrt{K.E.}$$

When kinetic energy is halved, the radius is reduced to $\left(\frac{1}{\sqrt{2}}\right)$ times its initial value.

Case Study Answers-

1. Answer :

- i. (a) Remains stationary.

Explanation:

For stationary electron, $\vec{v} = 0$

$$\therefore \text{Force on the electron is, } \vec{F}_m = -e(\vec{v} \times \vec{B}) = 0$$

- ii. (d) The proton will continue to move with velocity v along the axis.

Explanation:

$$\text{Force on the proton, } \vec{F}_B = e(\vec{v} \times \vec{B})$$

Since, \vec{v} is parallel to \vec{B}

$$\therefore \vec{F}_B = 0$$

Hence proton will continue to move with velocity v along the axis of solenoid.

- iii. (b) The particle is moving and magnetic field is perpendicular to the velocity.

Explanation:

Magnetic force on the charged particle q is,

$$\vec{F}_m = q(\vec{v} \times \vec{B}) \text{ or } F_m = qvB \sin \theta$$

where θ is the angle between \vec{v} and \vec{B} .

Out of the given cases, only in case (b) it will experience the force while in other cases it will experience no force.

- iv. (a) In z-y plane.

Explanation:

$$\begin{aligned} \vec{F} &= q(\vec{v} \times \vec{B}) \\ &= q[2\vec{i} \times (\vec{i} + 2\vec{j} + 3\vec{k})] = (4q)\vec{k} - (6q)\vec{j} \end{aligned}$$

- v. (c) Both electric and magnetic field.

Explanation:

When an electric charge is moving both electric and magnetic fields are produced, whereas a static charge produces only electric field.

2. Answer :i. (d) 9975Ω **Explanation:**

A galvanometer can be converted into a voltmeter of given range by connecting a suitable high resistance R in series of galvanometer, which is given by,

$$R = \frac{V}{I_g} - G = \frac{100}{10 \times 10^{-3}} - 25 = 10000 - 25 = 9975\Omega$$

ii. (c) 15000Ω **Explanation:**

An ideal voltmeter should have a very high resistance.

iii. (c) 990Ω **Explanation:**

$$\text{Resistance of voltmeter} = \frac{25}{25 \times 10^{-3}} = 1000\Omega$$

$$\therefore X = 1000 - 10 = 990\Omega$$

iv. (d) A high resistance R is connected in series with MCG.**Explanation:**

To convert a moving coil galvanometer into a voltmeter, it is connected with a high resistance in series.

The voltmeter is connected in parallel to measure the potential difference.

As the resistance is high, the voltmeter itself does not consume current.

v. (d) Infinity.

Explanation:

The resistance of an ideal voltmeter is infinity.



C V RAMAN
P U C O L L E G E
I N D I

CHAPTER 5: MAGNETISM AND MATTER

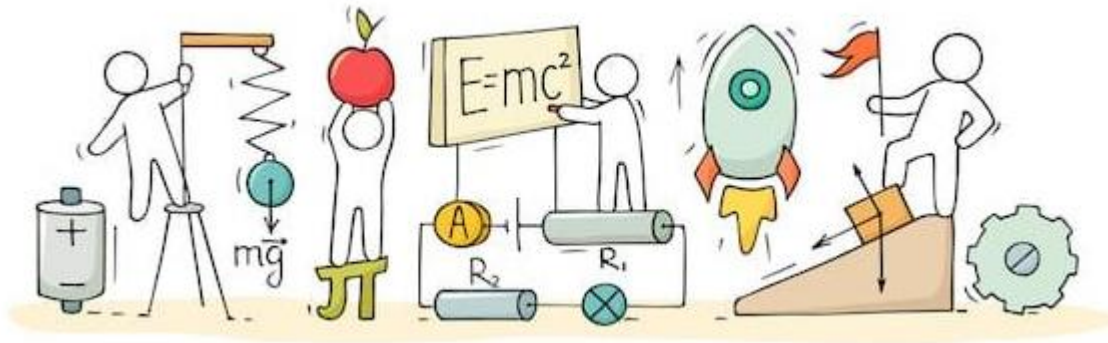

MAGNETISM AND MATTER

Bar Magnet:

When iron filings are sprinkled on a sheet of glass placed over a short bar magnet, a particular pattern is formed and following conclusions are drawn

- The bar magnet has poles similar to the positive and negative charge of an electric dipole.
- One pole is designated as north pole and other as south pole.
- When suspended freely, these poles point approximately towards the geographic north and south poles.
- Like poles repel each other and unlike poles attract each other.
- The poles of a magnet can never be separated.

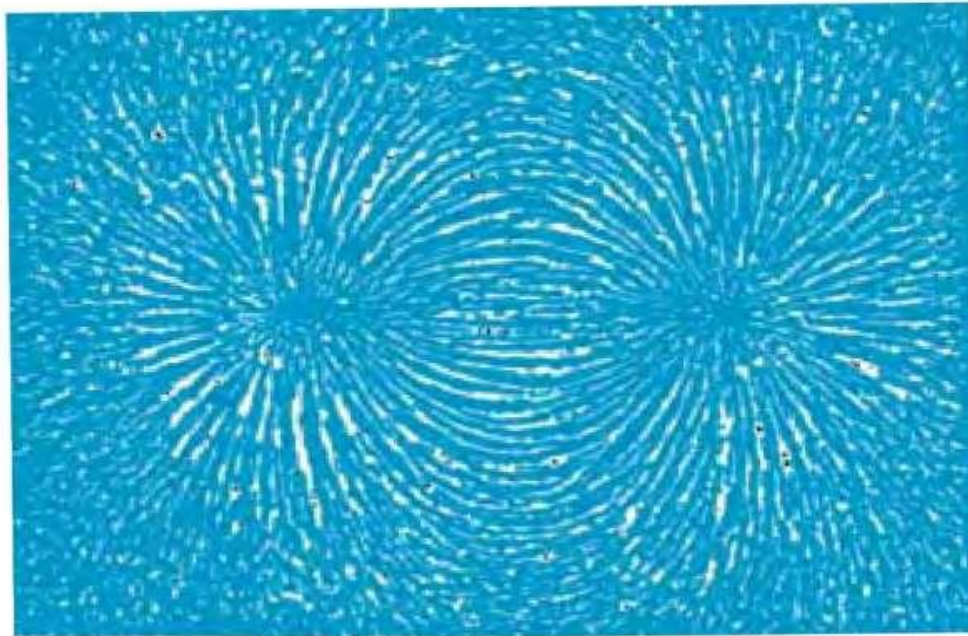

Magnetic Field Lines:

- Magnetic field line is an imaginary curve, the tangent to which at any point gives direction of magnetic field B at that point.
- The magnetic field lines of a magnet form close-continuous loop.
- Outside the body of magnet, the direction of magnetic field lines are from north pole to south pole.
- No two magnetic field lines can intersect each other. This is because at the point

of intersection, we can draw two tangents. This would mean two directions of magnetic field at the same point, which is not possible.

- Larger the number of field lines crossing per unit area, the stronger is the magnitude of the magnetic field B .

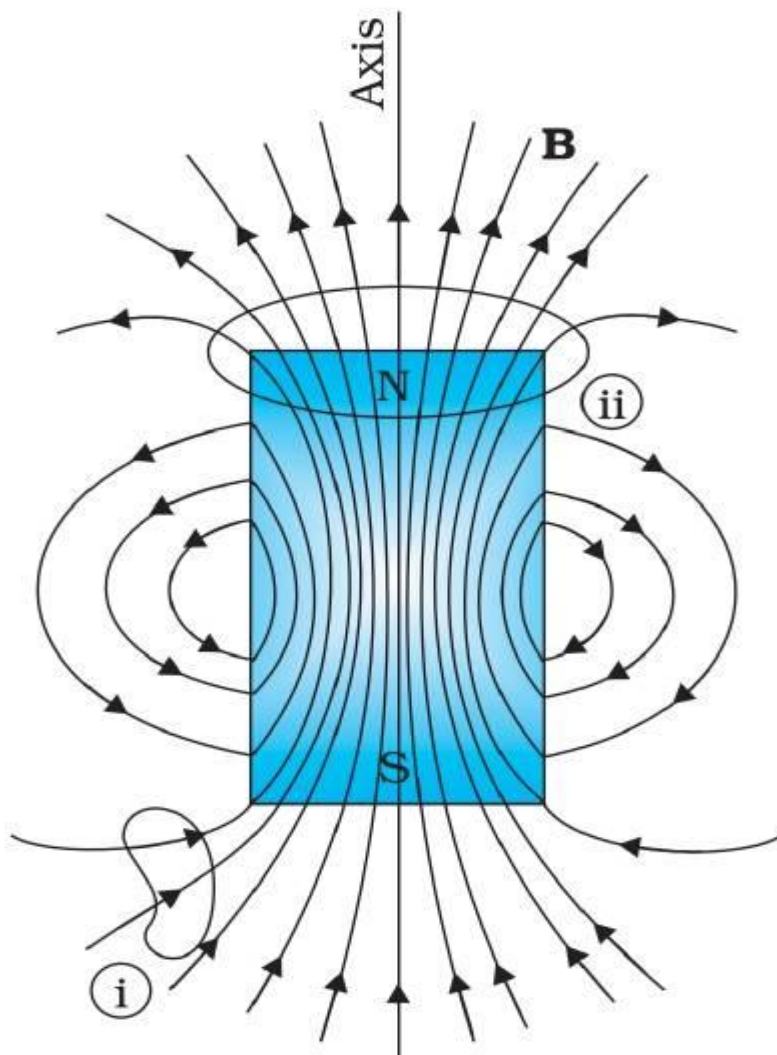

Coulomb's Law of Magnetism:

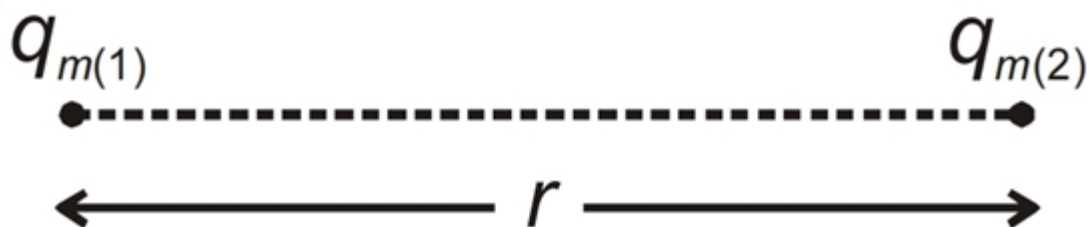

Let pole strength of a monopole be q_m , then magnetic force between two isolated poles kept at separation r is.

$$F \propto \frac{q_m(1) \times q_m(2)}{r^2}$$

$$F = \frac{\mu_0 q_m(1) \times q_m(2)}{4\pi r^2}$$

This force will be attractive if one pole is North and other is South and force will be repulsive if both poles are of same type (i.e., North-North or South-South).

Magnetic Field due to a Monopole:

Magnetic field due to monopole at a point is equal to magnetic force experienced by a unit pole strength if kept at that point.

$$B = \frac{\mu_0 m}{4\pi r^2}$$

It is away from pole if it is N-pole and it is towards pole if it is S-pole.

Magnetic Dipole Moment of a Bar Magnet:

It is equal to the product of any one pole strength and separation between two poles.

$$M = m \times 2l$$

It is directed from South-pole to north-pole.

Gauss's Law in Magnetism:

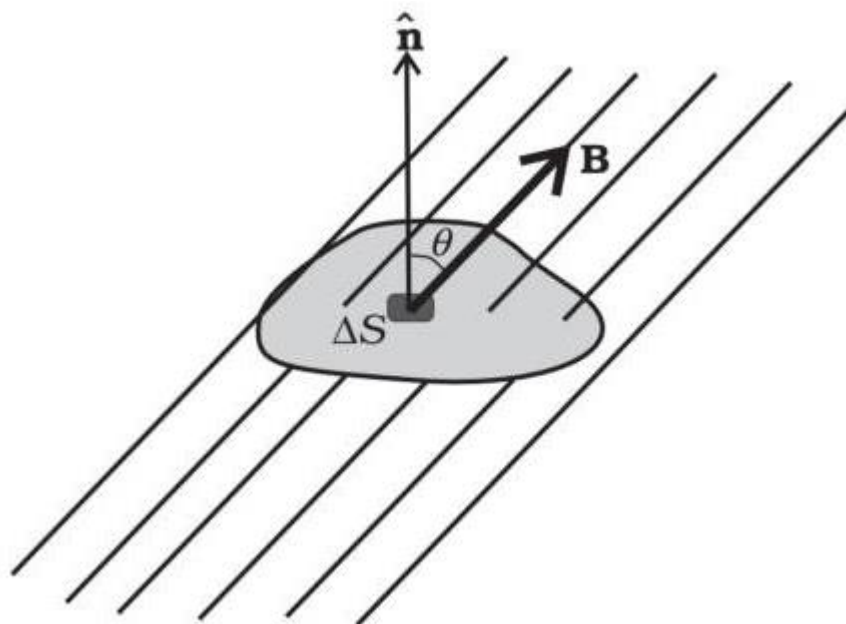

This law states that “the surface integral of a magnetic field over a closed surface is zero i.e., the net magnetic flux through any closed surface is always zero”.

$$\oint \vec{B} \cdot d\vec{s} = 0$$

Earth's Magnetism:

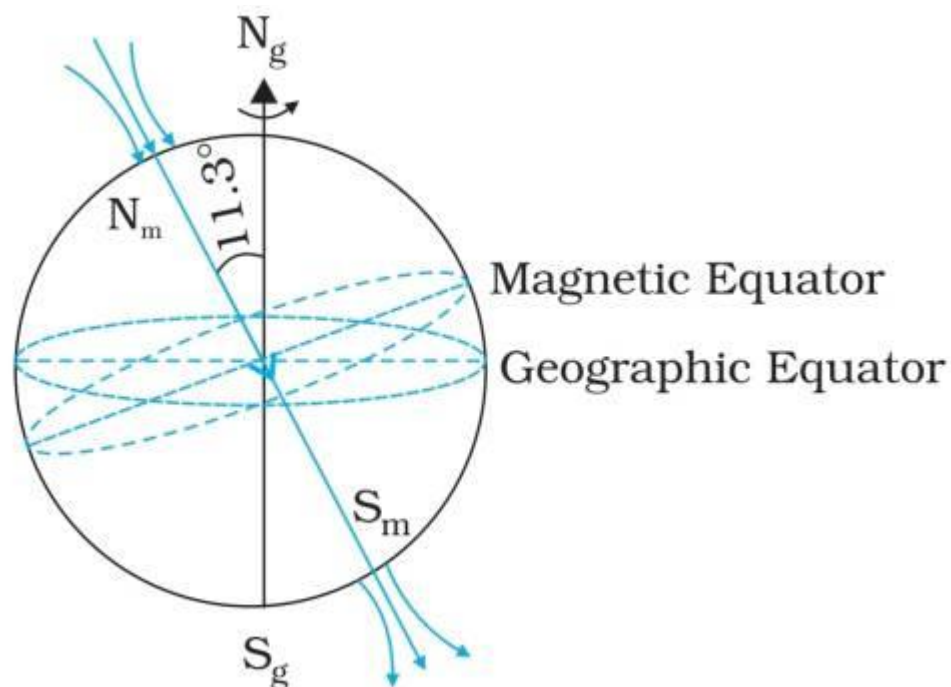

1. The earth's magnetism was assumed to arise from a very large bar magnet placed deep inside earth along its rotational axis but main argument against theory is that the interior of earth is too hot to maintain any magnetism.
2. The pattern of earth's magnetic field varies with position as well as time. This is most affected by solar wind.
3. The magnetic field lines of earth appear same as a magnetic dipole located at the center of the earth.
4. The pole near the geographic north pole is called the north magnetic pole and the pole near the geographic south pole is called the south magnetic pole.
5. **Geographic meridian:** It is a vertical plane passing through the geographic north-south direction. It contains the longitude circle and axis of rotation of the earth.
6. **Magnetic meridian:** It is a vertical plane passing through N-S line of freely suspended magnet.

Magnetic Declination:

It is angle between the true geographic north-south direction and the north south line shown by a compass needle at a place. Its value is more at higher latitude and smaller near equator. The declination in India is small.

Magnetic Inclination or Dip:

It is angle between axis of needle, (in magnetic meridian) which is free to move about a horizontal axis and horizontal. Thus, dip is an angle that total magnetic field of earth B_e makes with the surface of the earth. Angle of dip is maximum $\delta = 90^\circ$ at poles. It is zero at magnetic equator.

Classification of Magnetic Materials:

Magnetic materials are broadly classified as:

Diamagnetic: Diamagnetism is a fundamental property of all matter, although it is usually very weak. It is due to the non-cooperative behavior of orbiting electrons when exposed to an applied magnetic field.

Paramagnetic: This class of materials, some of the atoms or ions in the material have a net magnetic moment due to unpaired electrons in partially filled orbitals.

Ferromagnetic: When you think of magnetic materials, you probably think of iron, nickel, or magnetite. Unlike paramagnetic materials, the atomic moments in these materials exhibit very strong interactions.

Curie's Law:

Magnetic susceptibility of paramagnetic substance is inversely proportional to absolute temperature T .

$$\chi_m \propto \frac{1}{T}$$

$$\chi_m = \frac{C}{T}$$

The constant C is called Curie's constant.

Curie-Weiss law:

At temperature above the Curie temperature, a ferromagnetic substance becomes an ordinary paramagnetic substance whose magnetic susceptibility obeys the Curie-Weiss law according to which

$$\chi_m = \frac{C}{T - T_c}$$

Hard and Soft Magnets:

Hard Magnets:

The ferromagnetic material which retains magnetization for a long period of time are called hard magnetic material or hard ferromagnets. Some hard magnetic materials are Alnico (an alloy of iron, aluminium, nickel, cobalt and copper) and naturally occurring lodestone.

Soft Magnets:

The ferromagnetic material which retains magnetization as long as the external field persists are called soft magnetic materials or soft ferromagnets. Soft ferromagnets is soft iron. Such material is used for making electromagnets.

Permanent Magnets and Electromagnets:

Permanent Magnets: The substances which at room temperature retain their magnetization for long period of time are called Permanent magnets. Permanent magnets should have.

- High retentivity
- High coercivity.

As the material in this case is never put to cyclic changes of magnetization, hence hysteresis is immaterial. From the viewpoint of these facts, steel is more suitable for the construction of permanent magnets than soft iron. The fact that the retentivity of iron is little greater than that of steel is outweighed by the much smaller value of its coercivity.

Electromagnets: An electromagnet is a temporary strong magnet and is just a solenoid with its winding on a soft iron core which has high permeability and low retentivity.

Hysteresis:

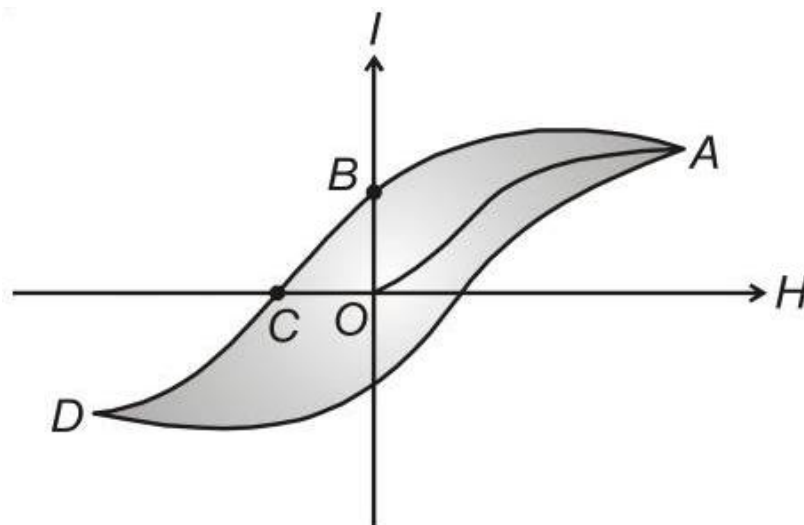

- When intensity of magnetization (I) of ferromagnetic substances is plotted against magnetic intensity for a complete cycle of magnetization and demagnetization the resulting loop is called hysteresis loop.
- When intensity of magnetizing field (H) is increased, the intensity of magnetization increases, because more and more domains are aligned in the direction of applied field.
- When all domains are aligned, material is magnetically saturated. Beyond this if intensity of magnetizing field (H) is increased, intensity of magnetization (I) does not increase.
- The value of intensity of magnetization (I) left in the material at $H = 0$, is called retentivity or remanence.
- Now if magnetizing field is applied in reverse direction and its intensity H is increased, material starts de-magnetizing. The value of magnetizing field needed to reduce magnetization to zero is called coercivity (OC).
- As reverse magnetizing field is increased further, the material again becomes saturated. Now, if the magnetizing field is reduced after attaining the reverse saturation, the cycle repeats itself.
- The area enclosed by the loop represents loss of energy during a cycle of magnetization and demagnetization.

Relation Between Horizontal and Vertical Component:

Squaring and adding equation (1) and (2), we get

$$B_H^2 + B_V^2 = B_e^2 (\cos^2 \delta + \sin^2 \delta)$$

$$B_e = \sqrt{B_H^2 + B_V^2}$$

Dividing equation (2) by (1)

$$\frac{B_V}{B_H} = \tan \delta$$

Relative Permeability (μ_r):

It is the ratio of permeability of a medium to that of permeability of free space.

$$\mu_r = \frac{\mu}{\mu_0}$$

Class : 12th Physics
Chapter- 5 : Magnetism and Matter

$$|\vec{\mu}| = iA = \frac{ev}{2\pi r} \times \pi r^2 = evr/2$$

$$\vec{\mu} = \frac{-e}{2m_e} \vec{L}$$

$$\mu = md$$

m = magnetic charge or pole strength
 d = separation between poles
 r = radius of circular orbit
 e = charge on electron
 v = speed of electron;
 L = angular momentum
 m_e = mass of electron

Current loop of area $A = \pi r^2$ carrying current i may be replaced by a magnetic dipole of dipole moment $\mu = md = iA$

Angle made by earth's magnetic field with horizontal in the magnetic direction
 $\delta_{\text{equator}} = 0, \delta_{\text{pole}} = 90^\circ$

Tendency to increase the magnetic field due to magnetization
 e.g. Al, Mn I, $\chi_m, \mu_r > 1$

Tendency to magnetise in a direction opposite to direction of magnetic field
 e.g. Bi, Cu, Hg, Ni, $\mu_r, \chi_m < 1$

Tendency of strongly magnetization in the direction of magnetic field.
 e.g. Fe, Co, Ni, $\mu_r, \chi_m \gg 1$

Angle b/w magnetic meridian and geographical meridian.

$$B_H = B \cos \theta$$

$$B_H \text{ (at pole)} = 0$$

$$B_H \text{ (at equator) is maximum}$$

$$\mu = NIA$$

N = no. of turns
 I = current
 A = area

Declination

Horizontal component

Inclination or dip

Earth is a natural source of magnetic field having geometric north and geometric south pole

Para-magnetism

Ferromagnetism

Diamagnetism

Magnetic Substance

In 1833, Carl Friedrich Gauss and Wilhelm Weber Made the first Electromagnetic Telegraph

Magnetism and Matter

Magnetic field lines

Imaginary lines which continuously represent the direction of magnetic field.



Electromagnets

Magnet in which the magnetic field is produced by an electric current. Magnetic field disappears when current is turned off.

Magnetic Terms

Magnetic Intensity

Time period oscillating bar magnet

Intensity of magnetization

Magnetic permeability

Magnetic susceptibility

$$I = \frac{M}{V}$$

$$H = \frac{B_0}{\mu}$$

$$\mu = \mu_0(1 + \chi_m)$$

$$\mu = \mu_0(1 + \chi_m)$$

$$\chi = \frac{I}{H}$$

$$T = 2\pi \sqrt{\frac{I}{MB}}$$

Magnetic field Intensity

Torque

potential Energy of a Field-Magnet System

$$U_\theta = U_0 - U_{90^\circ} = -MB \cos \theta = -\vec{M} \cdot \vec{B}$$

we take P.E. at $\theta = 90^\circ$ to be zero

• End-on-position
 $= \frac{\mu_0}{4\pi} \frac{2M}{d^3}$

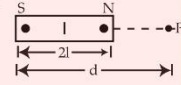

$M = 2ml$
 $d \gg l$

• Broadside-on Position
 $B = \frac{\mu_0}{4\pi} \frac{M}{(d^2 + l^2)^{3/2}}$

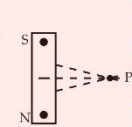

For $d \gg l$
 $B = \mu_0 M / 4\pi d^3$

$$\vec{\tau} = \vec{M} \times \vec{B} = MB \sin \theta$$

$$M = 2ml$$

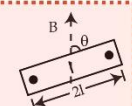
$$B = \text{Magnetic field}$$

Important Questions

Multiple Choice questions-

- The earth behaves as a magnet with magnetic field pointing approximately from the geographic
 - North to South
 - South to North
 - East to West
 - West to East
- The strength of the earth's magnetic field is
 - constant everywhere.
 - zero everywhere.
 - having very high value.
 - vary from place to place on the earth's surface.
- Which of the following is responsible for the earth's magnetic field?
 - Convective currents in earth's core
 - Diversive current in earth's core.
 - Rotational motion of earth.
 - Translational motion of earth.
- Which of the following independent quantities is not used to specify the earth's magnetic field?
 - Magnetic declination (θ).
 - Magnetic dip (δ).
 - Horizontal component of earth's field (BH).
 - Vertical component of earth's field (BV).
- Let the magnetic field on earth be modelled by that of a point magnetic dipole at the centre of earth. The angle of dip at a point on the geographical equator is
 - always zero
 - positive, negative or zero
 - unbounded
 - always negative
- The angle of dip at a certain place where the horizontal and vertical components

of the earth's magnetic field are equal is

- (a) 30°
- (b) 75°
- (c) 60°
- (d) 45°

7. The vertical component of earth's magnetic field. at a place is $\sqrt{3}$ times the horizontal component

the value of angle of dip at this place is

- (a) 30°
- (b) 45°
- (c) 60°
- (d) 90°

8. At a given place on earth's surface the horizontal component of earth's magnetic field is 2×10^{-5} T and resultant magnetic field is 4×10^{-5} T. The angle of dip at this place is

- (a) 30°
- (b) 60°
- (c) 90°
- (d) 45°

9. Which of the following property shows the property of ferromagnetic substances?

- (a) The ferromagnetic property depends on temperature. '
- (b) The ferromagnetic property does not depend on temperature.
- (c) At high enough temperature ferromagnet becomes a diamagnet.
- (d) At low temperature ferromagnet becomes a paramagnet.

10. The primary origin of magnetism lies in

- (a) atomic current and intrinsic spin of electrons.
- (b) polar and non-polar nature of molecules.
- (c) pauli exclusion principle.
- (d) electronegative nature of materials.

9. The magnetic moment of a current I carrying circular coil of radius r and number of turns N varies as

- (a) $\frac{1}{r_2}$
 (b) $\frac{1}{r}$
 (c) r
 (d) r^2

10. A short bar magnet has a magnetic moment of 0.65 J T^{-1} , then the magnitude and direction of the magnetic field produced by the magnet at a distance 8 cm from the center of magnet on the axis is

- (a) $2.5 \times 10^{-4} \text{ T}$, along NS direction
 (b) $2.5 \times 10^{-4} \text{ T}$ along SN direction
 (c) $4.5 \times 10^{-4} \text{ T}$, along NS direction
 (d) $4.5 \times 10^{-4} \text{ T}$, along SN direction

Very Short:

1. A small magnetic needle pivoted at the center is free to rotate in a magnetic meridian. At what place will the needle be vertical?
2. What is the angle of dip at a place where the horizontal and vertical components of the earth's magnetic field are equal?
3. How does the intensity of a paramagnetic sample vary with temperature?
4. What should be the orientation of a magnetic dipole in a uniform magnetic field so that its potential energy is maximum?
5. What is the value of angle of dip at a place on the surface of the earth where the ratio of the vertical component to the horizontal component of the earth's magnetic field is $\frac{1}{\sqrt{3}}$?
6. Where on the surface of the earth is the angle of dip 90° ? (CBSE AI 2011)
7. Where on the surface of the earth is the angle dip zero? (CBSE AI 2011)
8. What are permanent magnets? Give one example. (CBSE Delhi 2013)
9. At a place, the horizontal component of the earth's magnetic field is B , and the angle of dip is 60° . What is the value of the horizontal component of the earth's magnetic field at the equator? (CBSE Delhi 2017)
10. Is the steady electric current the only source of the magnetic field? Justify your answer. (CBSE Delhi 2013C)

Short Questions:

- 1.

(a) Define the term magnetic susceptibility and write its relation in terms of relative magnetic permeability.

(b) Two magnetic materials A and B have relative magnetic permeabilities of 0.96 and 500. Identify the magnetic materials A and B. (CBSE AI, Delhi 2018C)

2. A magnetic needle free to rotate in a vertical position orient itself with its axis vertical at a certain place on the earth. What are the values of?

(a) the angle of dip and

(b) the horizontal component of the earth's magnetic field at this place? Where will this place be on the earth?

3. Out of the two magnetic materials 'A' has relative permeability slightly greater than unity while 'B' has less than unity. Identify the nature of the materials 'A' and 'B'. Will their susceptibilities be positive or negative? (CBSE Delhi 2014)

4. A magnetic needle free to rotate in a vertical plane parallel to the magnetic meridian has its northern tip down at 60° with the horizontal. The horizontal component of the earth's magnetic field at the place is known to be 0.4 G. Determine the magnitude of the earth's magnetic field at the place. (CBSE Delhi 2011)

5. The susceptibility of a magnetic material is -0.085. Identify the type of magnetic material. A specimen of this material is kept in a non-uniform magnetic field. Draw the modified field pattern.

6. A uniform magnetic field gets modified as shown below when two specimens X and Y are placed in it.

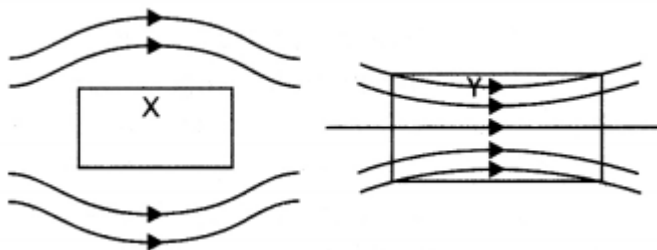

(a) Identify the two specimens X and Y.

(b) State the reason for the behavior of the field lines in X and Y.

7. Three identical specimens of magnetic materials nickel, antimony, and aluminum are kept in a non-uniform magnetic field. Draw the modification in the field lines in each case. Justify your answer.

8. Define neutral point. Draw lines of force when two identical magnets are placed at a finite distance apart with their N-poles facing each other. Locate the neutral points.

Long Questions:

1. Write the expression for the magnetic dipole moment for a closed current loop. Give its SI unit. Derive an expression for the torque experienced by a magnetic dipole in a uniform magnetic field.

2.

(a) State Gauss's law for magnetism. Explain Its significance.

(b) Write the four Important properties of the magnetic field lines due to a bar magnet. (CBSE Delhi 2019).

Assertion and Reason Questions-

1. Two statements are given-one labelled Assertion(A) and the other labelled Reason (R). Select the correct answer to these questions from the codes(a), (b), (c) and (d) as given below.

- a) Both A and R are true and R is the correct explanation of A.
- b) Both A and R are true but R is NOT the correct explanation of A.
- c) A is true but R is false.
- d) A is false and R is also false.

Assertion (A): There is only one neutral points on a horizontal board when a magnet is held vertically on the board.

Reason (R): At the neutral point the net magnetic field due to the magnetic and magnetic field of the earth is zero.

2. Two statements are given-one labelled Assertion(A) and the other labelled Reason (R). Select the correct answer to these questions from the codes(a), (b), (c) and (d) as given below.

- a) Both A and R are true and R is the correct explanation of A.
- b) Both A and R are true but R is NOT the correct explanation of A.
- c) A is true but R is false.
- d) A is false and R is also false.

Assertion (A): The true geographic north direction is found by using a compass needle.

Reason (R): The magnetic meridian of the earth is along the axis of rotation of the earth.

Case Study Questions-

1. The field of a hollow wire with constant current is homogeneous.

Curves in the graph shown give, as functions of radius distance r , the magnitude B of the magnetic field inside and outside four long wires a , b , c and d , carrying currents that are uniformly distributed across the cross sections of the wires. Overlapping portions of the plots are indicated by double labels.

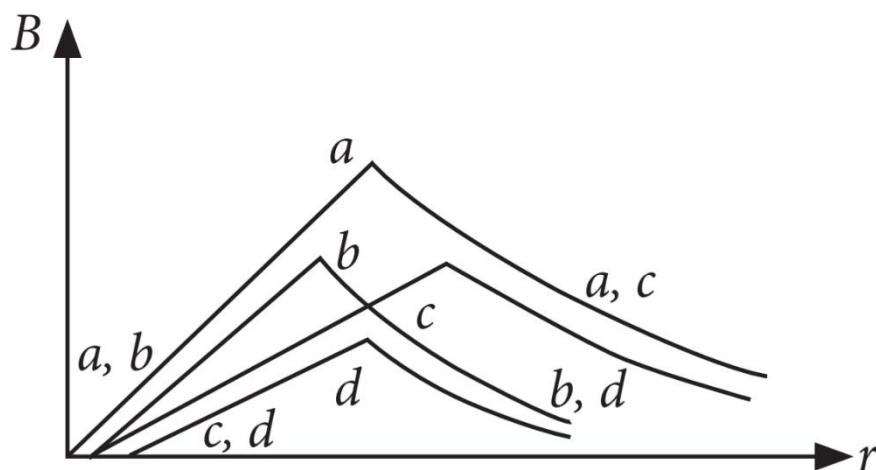

- (i) Which wire has the greatest magnitude of the magnetic field on the surface?
- a
 - b
 - c
 - d
- (ii) The current density in a wire a is:
- Greater than in wire c .
 - Less than in wire c .
 - Equal to that in wire c .
 - Not comparable to that of in wire c due to lack of information.
- (iii) Which wire has the greatest radius?
- a
 - b
 - c
 - d
- (iv) A direct current I flows along the length of an infinitely long straight thin walled pipe, then the magnetic field is:
- Uniform throughout the pipe but not zero.
 - Zero only along the axis of the pipe.
 - Zero at any point inside the pipe.

- d) Maximum at the centre and minimum at the edges.
- (v) In a coaxial, straight cable, the central conductor and the outer conductor carry equal currents in opposite direction. The magnetic field is zero.
- Outside the cable.
 - Inside the inner conductor.
 - Inside the outer conductor.
 - In between the two conductor.

2. The magnetic field lines of the earth resemble that of a hypothetical magnetic dipole located at the centre of the earth. The axis of the dipole is presently tilted by approximately 11.3° with respect to the axis of rotation of the earth.

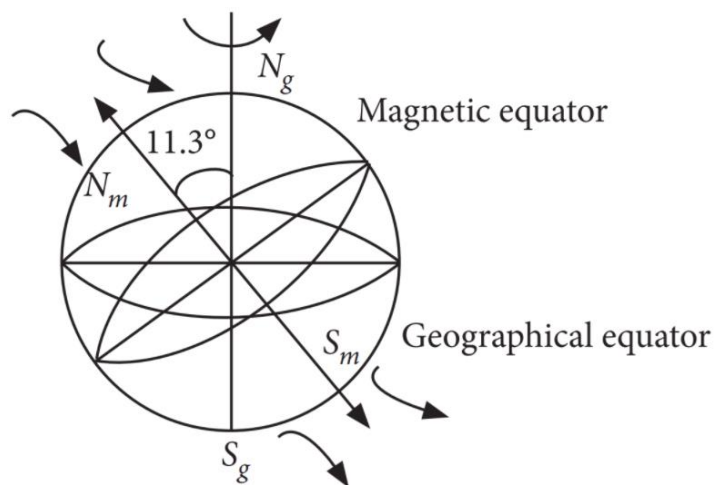

The pole near the geographic North pole of the earth is called the North magnetic pole and the pole near the geographic South pole is called South magnetic pole.

- (i) Magnetization of a sample is:
- 10^5T
 - 10^{-6}T
 - 10^{-5}T
 - 10^8T
- (ii) A bar magnet is placed North-South with its North-pole due North. The points of zero magnetic field will be in which direction from centre of magnet?
- North-South
 - East- West
 - North-East and South-West
 - None of these.
- (iii) The value of angle of dip is zero at the magnetic equator because on it:

- a) V and H are equal.
- b) The values of V and H are zero.
- c) The value of V is zero.
- d) The value of H is zero.
- (iv) The angle of dip at a certain place, where the horizontal and vertical components of the earth's magnetic field are equal, is:
- a) 30°
- b) 90°
- c) 60°
- d) 45°
- (v) At a place, angle of dip is 30° . If horizontal component of earth's magnetic field is H, then the total intensity of magnetic field will be.
- a. $\frac{H}{2}$
- b. $\frac{2H}{\sqrt{3}}$
- c. $H\sqrt{\frac{3}{2}}$
- d. $2H$

✓ Answer Key:

Multiple Choice Answers-

1. Answer: b
2. Answer: d
3. Answer: a
4. Answer: d
5. Answer: b
6. Answer: d
7. Answer: c
8. Answer: b
9. Answer: a
10. Answer: a

Very Short Answers:

1. Answer: At the poles
2. Answer: 450
3. Answer: it decreases with the increase in temperature.
4. Answer: It should be anti-parallel to the applied magnetic field.
5. Answer:

$$\text{Using the expression } \tan \delta = \frac{B_V}{B_H} = \frac{1}{\sqrt{3}}$$

Therefore, $\delta = 30^\circ$

6. Answer: Poles.
7. Answer: Magnetic equator
8. Answer: It is an arrangement that has a permanent dipole moment, e.g. bar magnet.
9. Answer: Zero.
10. Answer: No, the magnetic field is also produced by alternating current.

Short Questions Answers:

1. Answer:
 - (a) It refers to the ease with which a substance can be magnetized. It is defined as the ratio of the intensity of magnetization to the magnetizing field. The required relation is $\mu_r = 1 + \chi_m$
 - (b)

A: Paramagnetic,

B: Ferromagnetic
2. Answer: The angle of dip is 90° and the horizontal component of the earth's magnetic field is zero. This place is the magnetic pole of the earth.
3. Answer:
 - 'A' is paramagnetic and 'B' is diamagnetic.
 - 'A' will have positive susceptibility while
 - 'B' will have negative susceptibility.
4. Answer:

Given $\delta = 30^\circ$, $B_H = 0.4 \text{ G}$, $B = ?$

Using the expression

$B_H = B \cos \delta$ we have

$$B = \frac{B_H}{\cos \delta} = \frac{0.4}{\cos 30^\circ} = \frac{0.4}{\sqrt{3}/2} = \frac{0.8}{\sqrt{3}} \text{ G}$$

5. Answer: The material is a diamagnetic material as diamagnetic materials have negative susceptibility. The modified field pattern is as shown below.

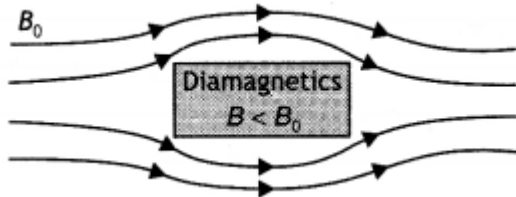

6. Answer:

(a) X is a diamagnetic substance and Y is a paramagnetic substance.

(b) This is because the permeability of a diamagnetic substance is less than one and that of a paramagnetic substance is greater than one.

7. Answer: Nickel is ferromagnetic, antimony is diamagnetic, and aluminium is paramagnetic. Therefore, they will show the behaviour as shown in the following figures.

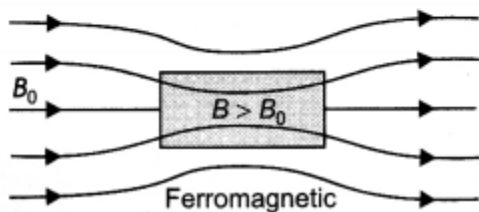
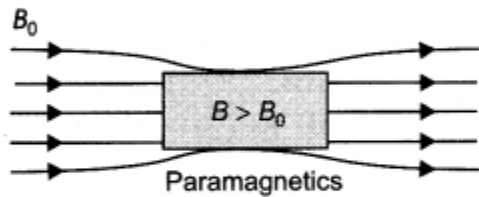
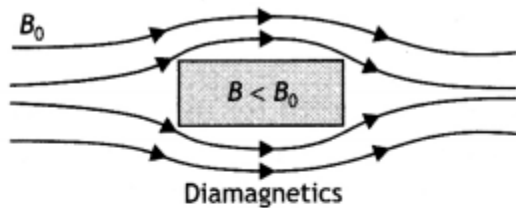

8. Answer: It is a point near a magnet where the magnetic field of the earth is completely balanced by the magnetic field of the magnet. The figure is as shown below.

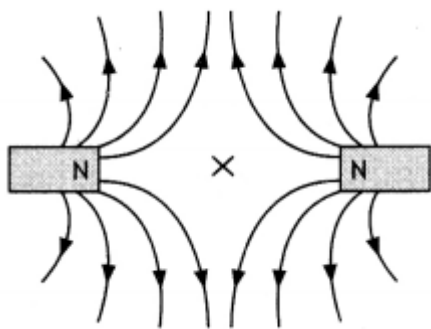

The cross indicates the neutral point.

Long Questions Answers:

1. Answer:

The required expression is $m = nIA$.

It is measured in $A\ m^2$.

Consider a uniform magnetic field of strength B . Let a magnetic dipole be suspended in it such that its axis makes an angle θ with the field as shown in the figure below. If ' m ' is the strength of each pole, the two poles experience two equal and opposite force ' mB ' each. These forces constitute a couple that tends to rotate the dipole. Suppose the couple exerts a torque of magnitude τ .

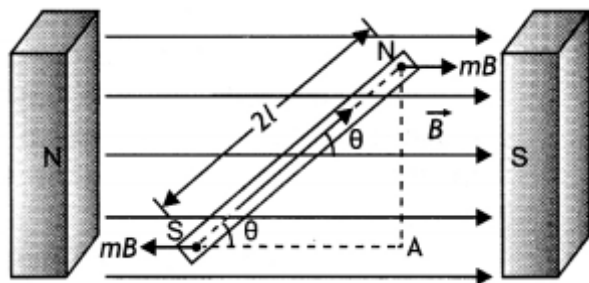

Then

$\tau = \text{either force} \times \text{arm of the couple}$

$$= mB \times AN = mB \times 2L \sin \theta$$

or

Since $m \times 2L$ is the magnetic dipole moment of the magnet.

Therefore $\tau = MB \sin \theta$ in vector form

we have $\vec{\tau} = \vec{M} \times \vec{B}$

2. Answer:

(a) Gauss's Law for magnetism states that "The total flux of the magnetic field, through any closed surface, is always

zero, i.e. $\oint \vec{B} \cdot d\vec{L} = 0$

This law implies that magnetic monopoles do not exist" or magnetic field lines form closed loops.

(b) Four properties of magnetic field lines are as follows:

- Magnetic field lines always form continuous closed loops.
- The tangent to the magnetic field line at a given point represents the direction of the net magnetic field at that point.
- The larger the number of field lines crossing per unit area, the stronger is the magnitude of the magnetic field.
- Magnetic field lines do not intersect.

Assertion and Reason Answers-

1. (b) Both A and R are true but R is NOT the correct explanation of A.

Explanation:

There will be only one neutral point on the horizontal board. This is because field of earth magnetic field is from south to north; and the field of pole on the board is radially outwards. At any point towards south of magnetic pole, field of earth and field of pole will cancel out to give a neutral point.

2. (d) A is false and R is also false.

Explanation:

From the compass we are able to know the poles. The north of compass points towards the magnetic south pole.

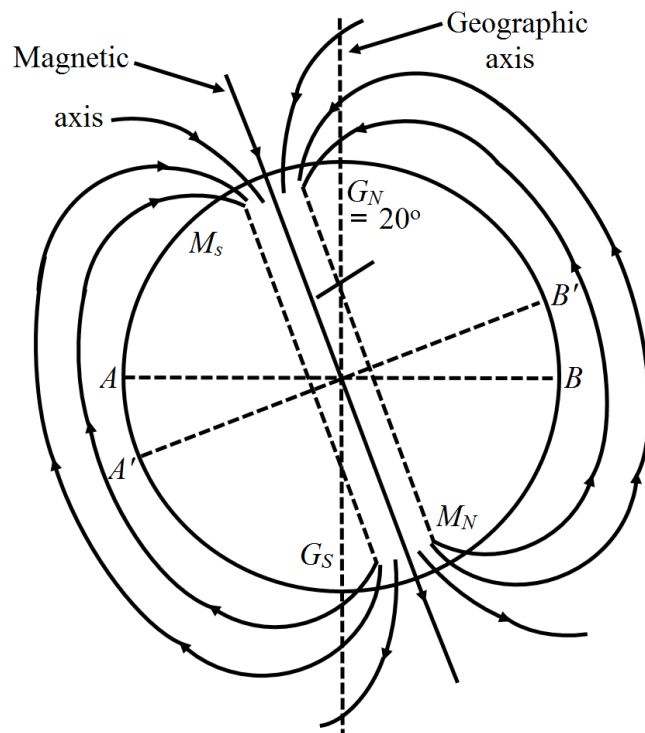

If we know the magnetic declination at that particular place (which is angle between geographic meridian and magnetic meridian) we can easily find out the true geographic north-south direction. Imaginary lines drawn along the earth's surface in the direction of the horizontal component of the magnetic field of the earth at all points passing through the north and south magnetic poles. This is similar to the longitudes of the earth, which pass through the geographic north and south poles.

Case Study Answers-

1. Answer :

(i) (a) a

Explanation:

It can be seen that slope of curve for wire a is greater than wire c.

(ii) (b) Less than in wire c.

Explanation:

Inside the wire

$$B(r) = \frac{\mu_0}{2\pi} \frac{I}{R^2} r \Rightarrow \frac{dB}{dr} = \frac{\mu_0}{2\pi} \frac{I}{R^2}$$

$$\text{i.e. slope} \propto \frac{I}{\pi R^2} \propto \text{Current density}$$

(iii) (c) c

Explanation:

Wire c has the greatest radius.

(iv) (c) Zero at any point inside the pipe.

(v) (a) Outside the cable.

2. Answer :

(i) (c) 10^{-5}T

(ii) (b) East- West

(iii) (c) The value of V is zero.

Explanation:

At equator vertical component of magnetic fields is zero.

(iv) (d) 45°

Explanation:

$$\text{Given, } V = H$$

$$\therefore \tan \delta = \frac{V}{H} = 1 \text{ or } \delta = 45^\circ$$

(v) (b) $\frac{2H}{\sqrt{3}}$

Explanation:

Given: Biot-Savart law can be expressed alternatively as Ampere circuital law.



C V RAMAN
P U C O L L E G E
I N D I

CHAPTER 6: ELECTROMAGNETIC INDUCTION

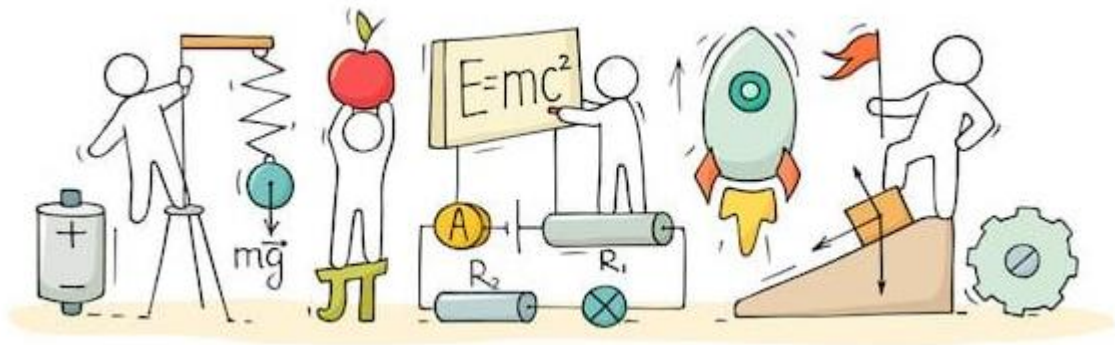

ELECTROMAGNETIC INDUCTION

Electromagnetic induction:

Whenever the magnetic flux linked with an electric circuit changes, an emf is induced in the circuit. This phenomenon is called electromagnetic induction.

Faraday's Laws of Electromagnetic Induction:

- Whenever the magnetic flux linked with a circuit changes, an induced emf is produced in it.
- The induced emf lasts so long as the change in magnetic flux continues.
- The magnitude of induced emf is directly proportional to the rate of change in magnetic flux, i.e.,

$$E \propto \frac{d\phi}{dt} \Rightarrow E = - \frac{d\phi}{dt}$$

where constant of proportionality is one and negative sign indicates Lenz's law.

Here, flux = $NBA \cos\theta$, SI unit of ϕ = weber,

CGS unit of ϕ = maxwell, 1 weber = 10^8 maxwell,

Dimensional formula of magnetic flux

$$[\phi] = [ML^{-2}T^{-2}A^{-2}]$$

Lenz's Law:

- The induced emf/ induced current direction is determined by this law.
- The direction of induced emf or current in a circuit, according to this law, is such that it opposes the source that generates it. The law of conservation of energy underpins this rule.
- When the N-pole of a bar magnet advances towards the coil, the flux associated with the loop increases, causing an emf. Induced current flows through the loop circuit since it is closed.
- Because the approaching north pole is the cause of this induced current, the induced current in the loop is directed in such a way that the front face of the loop behaves like the north pole. Therefore, induced current as seen by the observer O is an anticlockwise direction.

- The cause of generated emf in the coil can also be referred to as relative motion if the loop is free to move. As a result, the relative motion between the two objects works against the cause.
- The loop and the incoming magnet should be in opposition. As a result, the loop will begin to move in the direction of the magnet is moving.
- It is critical to keep in mind that whenever the reason of induced the new motion is always in the direction of the emf.

Eddy Current:

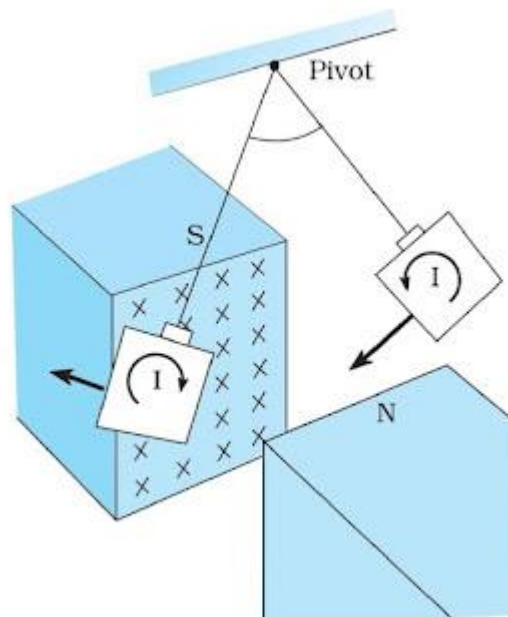

When a changing magnetic flux is given to a large piece of conducting material, it induces circling currents known as eddy currents. Eddy currents have huge magnitudes and heat up the conductor because the bulk conductor's resistance is usually low.

- These are circulating currents, similar to water eddies.
- The "Foucault current" is named after Foucault's experimental hypothesis.
- In a metallic block, the generation of eddy currents results in the loss of electric energy in the form of heat.
- As a result of the lamination and slotting processes, the resistance channel for eddy current circulation increases, weakening and lowering them and also reducing losses caused by them.

Eddy Current Applications:

Although eddy currents are generally unwelcome, they do have some helpful applications, as listed below.

- **Dead-Beat Galvanometer:** When a current is delivered via its coil, a deadbeat galvanometer's pointer comes to rest in the final equilibrium position instantaneously, with no oscillation around the equilibrium position.
This is accomplished by winding the coil around a metallic frame, which induces significant eddy currents that give electromagnetic damping.
- **When the train is running, the wheel moves in the air:** When the train is stopped by electric brakes, the wheel is made to move in an electromagnet created field. Eddy currents created in the wheels as a result of the changing flux work against the cause and bring the train to a halt.
- **Induction Furnace:** The heat of Joule causes a metal item to melt when it is placed in a rapidly changing magnetic field.
- **Speedometer:** In an automobile's speedometer, a magnet is geared to the vehicle's main shaft and rotates in accordance with the vehicle's speed. Hair springs are used to secure the magnet in an aluminium cylinder. When the magnet rotates, it produces eddy currents in the drum and drags it through an angle, which indicates the speed of the vehicle on a calibrated scale.
- **Energy Meter:** The armature coil of an energy meter has a metallic aluminium disc that rotates between the poles of a pair of permanent horseshoe magnets. The current induced in the disc as the armature spins tend to oppose the motion of the armature coil. Deflection is proportional to the energy consumed due to this braking effect.

Induced Charge Flow:

When a current is induced in the circuit due to the flux change, charge flows through the circuit and the net amount of charge which flows along the circuit is given as:

$$q = \int i dt = \int \frac{1}{R} \left| \frac{d\phi}{dt} \right| dt = \frac{1}{R} \int d\phi \quad q = \frac{|\Delta\phi|}{R} \text{ and } q = N \frac{|\Delta\phi|}{R} \text{ for } N \text{ turns}$$

The Experiments of Faraday and Henry:

Figure shows a coil C_1 connected to a galvanometer G . When the North-pole of a bar magnet is pushed towards the coil, the pointer in the galvanometer deflects, indicating the presence of electric current in the coil. The galvanometer does not show any deflection when the magnet is held stationary. When the magnet is pulled away from the coil, the galvanometer shows deflection in the opposite direction, which indicates reversal of the current's direction.

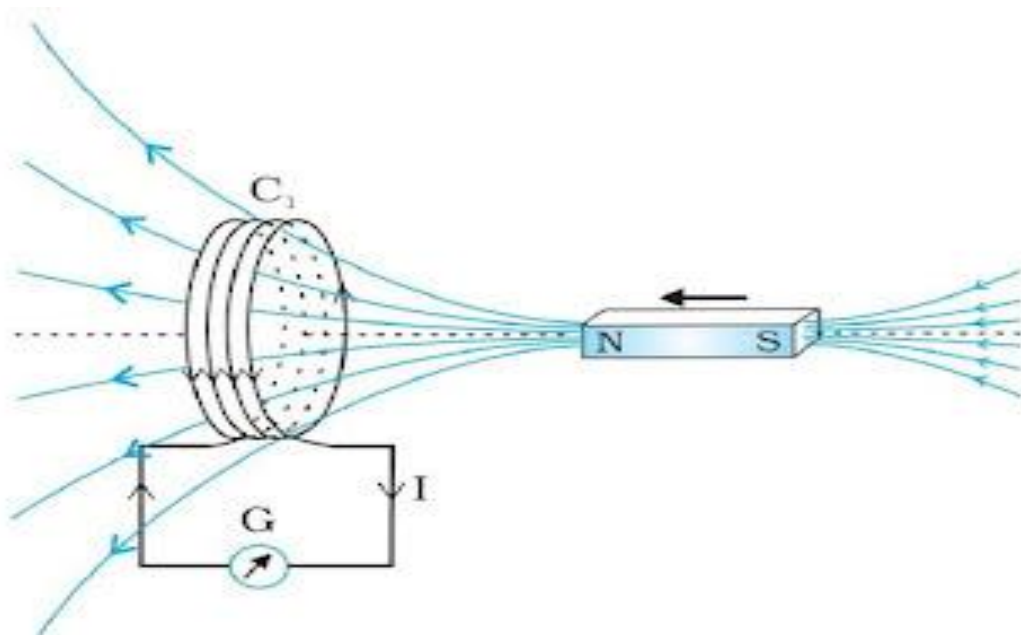

Moreover, when the South-pole of the bar magnet is moved towards or away from the coil, the deflections in the galvanometer are opposite to that observed with the North-pole for similar movements. Further, the deflection is found to be larger when the magnet is pushed towards or pulled away from the coil faster. Instead, when the bar magnet is held fixed and the coil C_1 is moved towards or away from the magnet, the same effects are observed. It shows that it is the relative motion between the magnet and the coil that is responsible for generation of electric current in the coil.

Fleming's Right Hand Rule:

If we stretch the thumb, the fore finger and the central finger of right hand in such a way that all three are perpendicular to each other, if thumb represent the direction of motion, the forefinger represent the direction of magnetic field, then central finger will represent the direction of induced current.

If R is the electrical resistance of the circuit, then induced current in the circuit is given

$$I = \frac{E}{R}$$

If induced current is produced in a coil rotated in uniform magnetic field, then.

$$I = NBA \omega \sin \frac{\omega t}{R} = I_0 \sin \omega t$$

where, $I_0 = NBA \omega$ = peak value of induced current,

N = number of turns in the coil,

B = magnetic induction,

ω = angular velocity of rotation and

A = area of cross-section of the coil.

Self-Induction:

The phenomena of production of induced emf in a circuit due to change in current flowing in its own, is called self-induction.

Mutual Induction:

The phenomena of production of induced emf in a circuit due to the change in magnetic flux in its neighbouring circuit, is called mutual induction.

Magnetic Flux:

Like electric flux, magnetic flux is proportional to the number of magnetic field lines passing through a surface. It is denoted by Φ_B . It is a scalar quantity.

Mathematically, $\Phi_B = \vec{B} \cdot \vec{A} = BA \cos \theta$

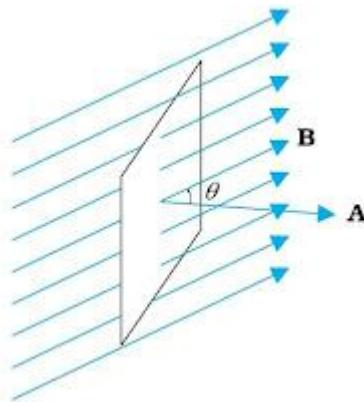

SI unit of magnetic flux is weber (Wb) ($1\text{Wb} = 1\text{tesla}\cdot\text{m}^2$). C.G.S. unit of magnetic flux is maxwell. The dimensional formula of magnetic flux is $[\text{ML}^2\text{T}^{-2}\text{A}^{-1}]$.

Motional Emf:

If a rod of length l moves perpendicular to a magnetic field B , with a velocity v , then induced emf produced in it given by.

$$E = B \times v \times l = Bvl$$

If a metallic rod of length l rotates about one of its ends in a plane perpendicular to the magnetic field, then the induced emf produced across its ends is given by.

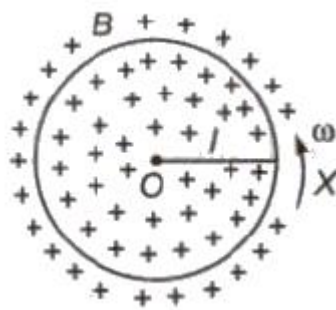

$$E = \frac{1}{2} b \omega r^2 = BAf$$

where, ω = angular velocity of rotation, f = frequency of rotation and $A = \pi r^2$ = area of disc.

The direction of induced current in any conductor can be obtained from Fleming's right hand rule.

A rectangular coil moves linearly in a field when coil moves with constant velocity in a uniform magnetic field, flux and induced emf will be zero.

A rod moves at an angle θ with the direction of magnetic field, velocity $E = -Blv \sin \theta$.

An emf is induced:

- When a magnet is moved with respect to a coil.
- When a conductor falls freely in East-West direction.
- When an Aeroplane flies horizontally.
- When strength of current flowing in a coil is increased or decreased, induced current is developed in the coil in same or opposite direction.
- When a train moves horizontally in any direction.

Induced Electric Field:

An electric field is induced in any region of space in which a magnetic field is changing with time. Induced electric field and magnetic field are at right angles to each other.

Consider a particle of charge q_0 moving around the ring in a circular path. The work done by the induced electric field in one revolution is $W = q_0 \epsilon$, where ϵ is the induced emf.

Also work done

$$W = \int \vec{F} \cdot d\vec{l}$$

$$W = q_0 \int \vec{E} \cdot d\vec{l}$$

$$q_0 \varepsilon = q_0 \int \vec{E} \cdot d\vec{l}$$

$$\varepsilon = \int \vec{E} \cdot d\vec{l}$$

By Faraday's law

$$\varepsilon = \frac{-d\Phi_B}{dt}$$

$$\therefore \int \vec{E} \cdot d\vec{l} = \frac{-d\Phi_B}{dt}$$

Lenz's Law and Conservation of Energy:

Lenz's law is in accordance with law of conservation of energy. As the induced current opposes the change in flux, work has to be done against the opposition offered by induced current in changing the flux. The work done appears as electrical energy in the loop.

AC Generator:

An ac generator converts mechanical energy into electrical energy.

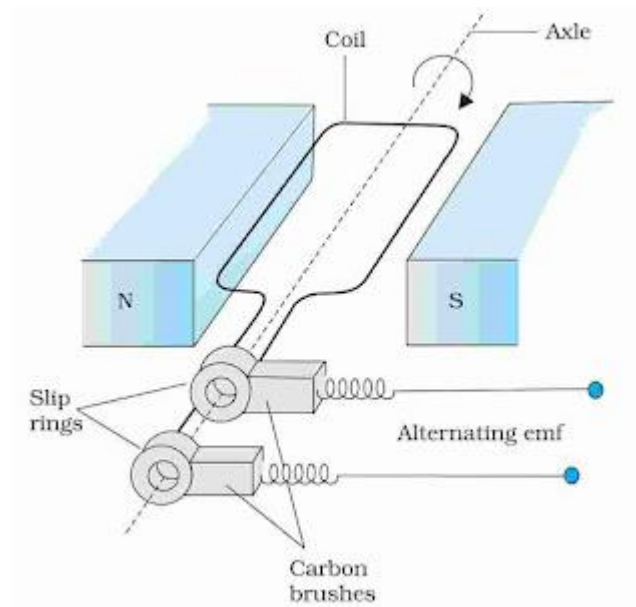

It consists of a coil mounted on a rotor shaft. The axis of rotation of the coil is perpendicular to the direction of the magnetic field. The coil (called armature) is mechanically rotated in the uniform magnetic field by some external means. The rotation of the coil causes the magnetic flux through it to change, so an emf is induced in the coil. The ends of the coil are connected to an external circuit by means of slip rings and brushes.

When the coil is rotated with a constant angular speed ω , the angle θ between the magnetic field vector B and the area vector A of the coil at any instant t is $\theta = \omega t$. As a result, the effective area of the coil exposed to the magnetic field lines changes with time, and the flux at any time to is.

$$\phi_B = BA \cos \theta$$

$$\phi_B = BA \cos \theta$$

From Faraday's law, the induced emf for the rotating coil of N turns is, then,

$$\begin{aligned} \varepsilon &= -N \frac{d\phi_B}{dt} \\ \varepsilon &= -NBA \frac{d}{dt} (\cos \omega t) \end{aligned}$$

Thus, the instantaneous value of the emf is,

$$\varepsilon = NBA\omega \sin \omega t$$

If we denote $NBA\omega$ as ε_0 ,

$$\varepsilon = \varepsilon_0 \sin \omega t$$

The direction of the current changes periodically and therefore the current is called alternating current (ac).

Class : 12th Physics
Chapter- 6 : Electromagnetic Induction

$L = \mu_0 n^2 \pi r^2 l$
 $n =$ no. of turns per unit length
 $\phi =$ flux $= (\mu_0 n i) \pi r^2$
 $r =$ radius of each loop of solenoid
 • Growth of current in LR Circuit
 $i = \frac{E}{R} (1 - e^{-tR/L}) = i_0 (1 - e^{-t\tau})$
 • Decay of current
 $i = i_0 e^{-t\tau}$
 • Energy stored in an Inductor
 $U = \frac{1}{2} Li^2$

Whenever flux of magnetic field through the area bounded by a closed conducting loop changes, an emf is produced in the loop. The emf is given by $E = -d\phi/dt$ where $\phi = \int \vec{B} \cdot d\vec{s}$ is the flux of the magnetic field through the area.

If a solenoid of N turns, the flux through each each turn $= \phi = \int \vec{B} \cdot d\vec{s}$
emf induced between the ends of coil $= E = -N \frac{d}{dt} \int \vec{B} \cdot d\vec{s}$

In 1831, Michael Faraday discovered electromagnetic induction and James Clerk Maxwell mathematically described it.

$\phi = Mi$
 $\frac{d\phi}{dt} = -M \frac{di}{dt}$
 $M_{12} = \mu_0 n_1 n_2 \pi r_1^2 l$
 $M_{21} = \mu_0 n_1 n_2 \pi r_2^2 l$
 Emf induced in an AC generator, $E = NBA\omega \sin \omega t$

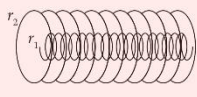

The direction of the induced current is such that it opposes the changes that has induced it.

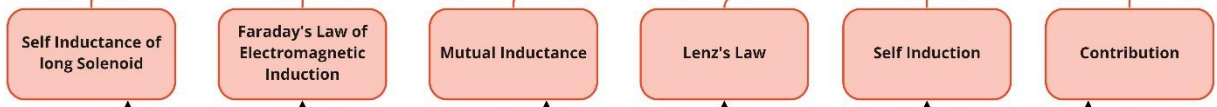

$I = \frac{E}{R} = -\frac{1}{R} \frac{d\phi}{dt}$

Induced current

Eddy Current

It is induced when magnetic flux linked with the conductor changes

Induced EMF

$E = \frac{d\phi}{dt}$

Motional EMF

EMF induced in a rotating conductor

$E = \left| \frac{d\phi}{dt} \right| = Bl \frac{dx}{dt}$
 $= Blv$
 $i = vbl / (R+r)$

 $r =$ resistance of rod moving with velocity v in uniform magnetic field \vec{B}

$E = \frac{1}{2} B\omega l^2$

Rectangular loop

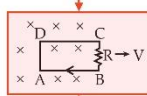

emf induced
 $E = vBl$
 $i = \frac{vBl}{R}$

Magnetic force on the loop
 $F = B^2 l^2 v / R$
= force required to move the loop with constant velocity (v)

Thermal power developed in the loop is
 $P = \frac{v^2 B^2 l^2}{R}$

Important Questions

Multiple Choice questions-

- The north pole of a long bar magnet was pushed slowly into a short solenoid connected to a short galvanometer. The magnet was held stationary for a few seconds with the north pole in the middle of the solenoid and then withdrawn rapidly. The maximum deflection of the galvanometer was observed when the magnet was
 - moving towards the solenoid
 - moving into the solenoid
 - at rest inside the solenoid
 - moving out of the solenoid
- The magnetic flux linked with a coil of N turns of area of cross section A held with its plane parallel to the field B is
 - $\frac{NAB}{2}$
 - NAB
 - $\frac{NAB}{4}$
 - zero
- Faraday's laws are consequence of the conservation of
 - charge
 - energy
 - magnetic field
 - both (b) and (c)
- Two identical coaxial coils P and Q carrying equal amount of current in the same direction are brought nearer. The current in
 - P increases while in Q decreases
 - Q increases while in P decreases
 - both P and Q increases
 - both P and Q decreases
- Direction of current induced in a wire moving in a magnetic field is found using
 - Fleming's left-hand rule
 - Fleming's right-hand rule
 - Ampere's rule
 - Right hand clasp rule
- Lenz's law is a consequence of the law of conservation of
 - charge
 - energy
 - induced emf
 - induced current

7. A solenoid is connected to a battery so that a steady current flows through it. If an iron core is inserted into the solenoid, the current will

- (a) increase
- (b) decrease
- (c) remain same
- (d) first increase then decrease

8. Which of the following statements is not correct?

- (a) Whenever the amount of magnetic flux linked with a circuit change, an emf is induced in circuit.
- (b) The induced emf lasts so long as the change in magnetic flux continues.
- (c) The direction of induced emf is given by Lenz's law.
- (d) Lenz's law is a consequence of the law of conservation of momentum.

9. There is a uniform magnetic field directed perpendicular and into the plane of the paper. An irregular shaped conducting loop is slowly changing into a circular loop in the plane of the paper. Then

- (a) current is induced in the loop in the anti-clockwise direction.
- (b) current is induced in the loop in the clockwise direction.
- (c) ac is induced in the loop.
- (d) no current is induced in the loop.

10. In the given figure current from A to B in the straight wire is decreasing. The direction of induced current in the loop is A

- (a) clockwise
- (b) anticlockwise
- (c) changing
- (d) nothing can be said

Very Short:

1. What is the function of a step-up transformer? (CBSE AI 2011C)

2. State Lenz's law. (CBSE AI 2012C)

3. How can the self-inductance of a given coil having 'N' number of turns, area of cross-section of 'A' and length T be increased? (CBSE AI 2012C)

4. How does the mutual inductance of a pair of coils change when

- (a) the distance between the coils is increased and
- (b) the number of turns in the coils is increased. (CBSE AI 2013)

5. The motion of the copper plate is damped when it is allowed to oscillate between the two poles of a magnet. What is the cause of this damping? (CBSE AI 2013)

6. Why is the core of a transformer laminated? (CBSE Delhi 2013C)
7. A metallic piece gets hot when surrounded by a coil carrying a high frequency alternating current. Why? (CBSE Delhi 2014C)
8. Name any two applications where eddy currents are used to advantage. (CBSE Delhi 2016C)
9. A long straight current-carrying wire passes normally through the centre of the circular loop. If the current through the wire increases, will there be an induced emf in the loop? Justify. (CBSE Delhi 2017)
10. Predict the polarity of the capacitor in the situation described below. (CBSE AI 2017)

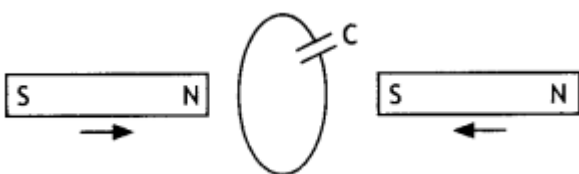

Short Questions:

1. An induced current has no direction of its own, comment.
2. How are eddy currents produced? Mention two applications of eddy currents?
3. Name and define the unit used for measuring the coefficient of mutual inductance. State the relation of this unit with the units of magnetic flux and electric current.
4. What are eddy currents? Write any two applications of eddy currents. (CBSE AI 2011)
5.
 - (a) Obtain the expression for the magnetic energy stored in a solenoid in terms of the magnetic field B , area A and length l of the solenoid.
 - (b) How is this magnetic energy per unit volume compared with the electrostatic energy per unit volume stored in a parallel plate capacitor? (CBSE Delhi 2011C)
6. State Lenz's Law.

A metallic rod held horizontally along the east-west direction is allowed to fall under gravity. Will there be an emf induced at its ends? Justify your answer. (CBSE Delhi 2013)
7. Starting from the expression for the energy $W = 1/2LI^2$, stored in a solenoid of self-inductance L to build up the current I , obtain the expression for the magnetic energy in terms of the magnetic field B , area A and length l of the solenoid having n

number of turns per unit length. Hence show that the energy density is given by $\frac{B^2}{2\mu_0}$. (CBSE Delhi 2013C)

(i) The magnetic energy is

(ii) The magnetic energy per unit volume is

8. Define mutual inductance. A pair of adjacent coils has a mutual inductance of 1.5 H. If the current in one coil changes from 0 to 20 A in 0.5 s, what is the change of flux linkage with the other coil? (CBSE Delhi 2016)

Long Questions:

1. 11 kW of electric power can be transmitted to a distant station at (i) 220 V or (ii) 22,000 V. Which of the two modes of transmission should be preferred and why? Support your answer with possible calculations.

2. A coil A is connected to a voltmeter V and the other coil B to an alternating current source D. If a large copper sheet C is placed between the two coils, how does the induced emf in coil A change due to current in coil B. Justify your answer.

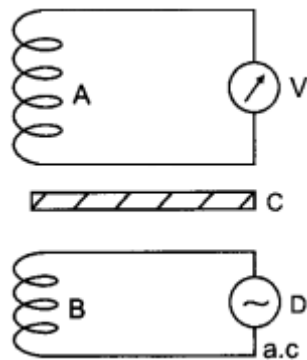

Assertion and Reason Questions-

1. Two statements are given-one labelled Assertion (A) and the other labelled Reason (R). Select the correct answer to these questions from the codes (a), (b), (c) and (d) as given below.

- a) Both A and R are true and R is the correct explanation of A.
- b) Both A and R are true but R is NOT the correct explanation of A.
- c) A is true but R is false.
- d) A is false and R is also false.

Assertion (A): An aircraft flies along the meridian, the potential develops at the ends of its wings.

Reason (R): Whenever there is change in the magnetic flux e.m.f. induces.

2. Two statements are given-one labelled Assertion (A) and the other labelled Reason (R). Select the correct answer to these questions from the codes (a), (b), (c) and (d) as given below.

- Both A and R are true and R is the correct explanation of A.
- Both A and R are true but R is NOT the correct explanation of A.
- A is true but R is false.
- A is false and R is also false.

Assertion (A): An artificial satellite with a metal surface is moving above the earth in a circular orbit. A current will be induced in satellite if the plane of the orbit is inclined to the plane of the equator.

Reason (R): The current will be induced only when the speed of satellite is more than 8km/ sec.

Case Study Questions-

1. In year 1820 Oersted discovered the magnetic effect of current. Faraday gave the thought that reverse of this phenomenon is also possible i.e., current can also be produced by magnetic field. Faraday showed that when we move a magnet towards the coil which is connected by a sensitive galvanometer. The galvanometer gives instantaneous deflection showing that there is an electric current in the loop.

Whenever relative motion between coil and magnet takes place an emf induced in coil. If coil is in closed circuit then current is also induced in the circuit. This phenomenon is called electromagnetic induction.

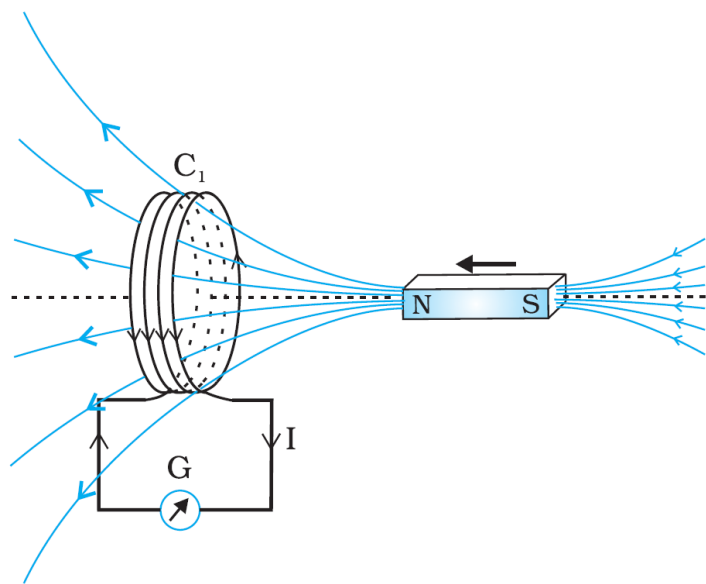

- The north pole of a long bar magnet was pushed slowly into a short solenoid connected to a galvanometer. The magnet was held stationary for a few seconds with the north pole in the middle of the solenoid and then withdrawn

rapidly. The maximum deflection of the galvanometer was observed when the magnet was:

- a) Moving towards the solenoid.
 - b) Moving into the solenoid.
 - c) At rest inside the solenoid.
 - d) Moving out of the solenoid.
- (ii) Two similar circular loops carry equal currents in the same direction. On moving the coils further apart, the electric current will.
- a) Remain unaltered.
 - b) Increases in one and decreases in the second.
 - c) Increase in both.
 - d) Decrease in both.
- (iii) A closed iron ring is held horizontally and a bar magnet is dropped through the ring with its length along the axis of the ring. The acceleration of the falling magnet is.
- a) Equal to g .
 - b) Less than g .
 - c) More than g .
 - d) Depends on the diameter of the ring and length of magnet.
- (iv) Whenever there is a relative motion between a coil and a magnet, the magnitude of induced emf set up in the coil does not depend upon the:
- a) Relative speed between the coil and magnet.
 - b) Magnetic moment of the coil.
 - c) Resistance of the coil.
 - d) Number of turns in the coil.
- (v) A coil of metal wire is kept stationary in a non-uniform magnetic field:
- a) A n emf and current both are induced in the coil.
 - b) A current but no emf is induced in the coil.
 - c) An emf but no current is induced in the coil.
 - d) Neither emf nor current is induced in the coil.

2. Currents can be induced not only in conducting coils, but also in conducting sheets or blocks. Current is induced in solid metallic masses when the magnetic flux threading

through them changes. Such currents flow in the form of irregularly shaped loops throughout the body of the metal. These currents look like eddies or whirlpools in water so they are known as eddy currents. Eddy currents have both undesirable effects and practically useful applications. For example it causes unnecessary heating and wastage of power in electric motors, dynamos and in the cores of transformers.

- (i) The working of speedometers of trains is based on:
 - a) Wattless currents.
 - b) Eddy currents.
 - c) alternating currents.
 - d) pulsating currents.
- (ii) Identify the wrong statement.
 - a) Eddy currents are produced in a steady magnetic field.
 - b) Induction furnace uses eddy currents to produce heat.
 - c) Eddy currents can be used to produce braking force in moving trains.
 - d) Power meters work on the principle of eddy currents.
- (iii) Which of the following is the best method to reduce eddy currents?
 - a) Laminating core.
 - b) Using thick wires.
 - c) By reducing hysteresis loss.
 - d) None of these.
- (iv) The direction of eddy currents is given by:
 - a) Fleming's left hand rule.
 - b) Biot-Savart law.
 - c) Lenz's law
 - d) Ampere-circuital law.
- (v) Eddy currents can be used to heat localised tissues of the human body. This branch of medical therapy is called:
 - a) Hyperthermia.
 - b) Diathermy.
 - c) Inductothermy.
 - d) None of these.

✓ Answer Key:

Multiple Choice Answers-

1. Answer: d
2. Answer: d
3. Answer: b
4. Answer: d
5. Answer: b
6. Answer: b
7. Answer: b
8. Answer: d
9. Answer: a
10. Answer: b

Very Short Answers:

1. Answer: The function of a step-up transformer is to step-up the alternating voltage.
2. Answer: It states that the direction of induced emf is such that it opposes the cause of its production.
3. Answer: By inserting a core of high permeability inside the coil.
4. Answer:
 - (a) decreases
 - (b) increases.
5. Answer: Production of eddy current.
6. Answer: To reduce the effects of eddy currents.
7. Answer: Due to the production of eddy current which generates heat.
8. Answer:
 - Electromagnetic damping
 - Induction furnace.
9. Answer: Yes, as there will be a change in magnetic flux.
10. Answer: The upper plate will be positive with respect to the lower plate in the capacitor.

Short Questions Answers:

1. Answer: Yes, it is perfectly correct to say that an induced current has no fixed direction of its own. The direction of induced current depends upon the change in magnetic flux because in accordance with Lenz's law the induced current always opposes the change in magnetic flux.
2. Answer: Eddy currents are the currents induced in the body of a thick conductor when the magnetic flux linked with the conductor changes. When a thick conductor is moved in a magnetic field, magnetic flux linked with it changes. In situations like these, we can have induced currents that circulate throughout the volume of a material.

Because their flow patterns resemble swirling eddies in a river, therefore they are called eddy currents.

- Electromagnetic braking, and
- Induction furnace.

3. Answer:

In SI the unit of mutual inductance is henry (H). Now from the expression

$$\varepsilon = - \frac{d\phi}{dt} = - M \frac{dl}{dt}$$

$$\text{we have } M = \varepsilon l \frac{dt}{dl}$$

Let $\varepsilon = 1$ volt and $dl/dt = 1 \text{ As}^{-1}$, then

$$M = 1 \text{ volt}/1 \text{ As}^{-1} = 1 \text{ henry.}$$

The mutual inductance of a coil is said to be 1 henry if a rate of change of current of 1 ampere per sec in the neighbouring coil induces in it an emf of 1 volt.

4. Answer:

Eddy currents are the currents induced in the body of a thick conductor when the magnetic flux linked with a bulk piece of conductor changes.

- Dead Beat Galvanometer, and
- Induction furnace.

5. Answer:

The magnetic field stored in a solenoid is given by the expression $U = \frac{1}{2} LI^2$.

But for a solenoid $B = \mu_0 nI$

or

$$I = B / \mu_0 n$$

Substituting in the above expression we have

$$U = \frac{1}{2} \times (\mu_0 n^2 A l) \left(\frac{B}{\mu_0 n} \right)^2 \text{ as } L = \mu_0 n^2 A l$$

$$U = \frac{1}{2} \frac{B^2 A l}{\mu_0}$$

We know that the energy stored per unit volume in a parallel plate capacitor is

$$U_E = \frac{1}{2} \epsilon_0 E^2$$

It is clear that in both cases the energy stored per unit volume is proportional to the square of the field intensity.

6. Answer: Lenz's law states that the polarity of the induced emf is such that it tends to oppose the cause of its production.

Yes, as it will cut the horizontal component of the earth's magnetic field.

7. Answer:

(i)

$$U = \frac{1}{2} L I^2 = \frac{1}{2} L \left(\frac{B}{\mu_0 n} \right)^2 \text{ since } B = \mu_0 n I$$

Now $L = \mu_0 n^2 A l$, therefore we have

$$U_B = \frac{1}{2} (\mu_0 n^2 A l) \left(\frac{B}{\mu_0 n} \right)^2 = \frac{1}{2 \mu_0} B^2 A l$$

(ii)

$$U_B = \frac{U_B}{V} = \frac{U_B}{A l} = \frac{B^2}{2 \mu_0}$$

8. Answer: Mutual inductance is numerically equal to the magnetic flux linked with a coil when the unit current passes through the neighbouring coil.

Given $M = 1.5 \text{ H}$, $dI = 20 - 0 = 20 \text{ A}$,

$dt = 0.5 \text{ s}$, $\Phi = ?$

$$\Phi = -M \frac{dI}{dt}$$

or

$$\Phi = -1.5 \times \frac{20}{0.5} = -60 \text{ Wb}$$

Long Questions Answers:

1. Answer:

1. Consider that 11000 watt of energy has to be transmitted. First at 220 V and then at 22000 V. When the power is transmitted at 220 V then the current flowing through the wires is $11000/220 = 50 \text{ A}$

2. When power is transmitted at 22000 V then the current through the wires is $11000 / 22000 = 0.5$ A. If R is the resistance of the line wire then the energy dissipated in the two cases is $2500R$ joule per sec and $0.25R$ joule per sec.

This shows that if energy is transmitted at low voltages there is more loss in energy than when it is transmitted at high voltages. Furthermore, if power is to be transmitted at low voltage, then the resistance of the line wire should be low, as such thick wires will be required. To support these thick wires strong poles situated close to each other will be needed. This will increase the cost of transmission. But at high voltages, even thin wires will do.

2. Answer:

In the absence of sheet C, an induced emf is set up in coil due to mutual induction phenomenon when an alternating current is passed through coil B.

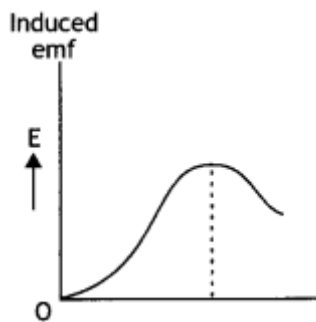

However, when induced copper sheet C is placed, eddy currents are set up in the sheet due to a change in flux.

Thus, now coil A has a positive effect due to coil B and a negative effect due to eddy currents in C. Consequently, the flux of coil A and hence the induced emf in coil A is decreased, i.e. the reading of voltmeter V is reduced.

Assertion and Reason Answers-

1. (a) Both A and R are true and R is the correct explanation of A.

Explanation:

As the aircraft flies, magnetic flux changes through its wings due to the vertical component of the earth's magnetic field. Due to this, induced emf is produced across the wings of the aircraft.

2. (c) Both A and R are true and R is the correct explanation of A.

Explanation:

When the satellite move in inclined plane with equatorial plane the value of magnetic field will change both in magnitude and direction. Due to this, the magnetic flux through the satellite will change and hence induced currents will be produced in the metal of the satellite. But no current will induce if satellite orbits in the equatorial

plane because the magnetic flux does not change through the metal of the satellite in this plane.

Case Study Answers-

1. Answer :

(i) (d) Moving out of the solenoid.

Explanation:

More rapid is the movement of bar magnet, more is the deflection observed in the galvanometer.

(ii) (c) Increase in both.

Explanation:

Two circular loops carrying current in the same direction will attract each other. If they are now separated, induced currents will try to keep status quo, by increasing the current in both the coils.

(iii) (b) Less than g .

Explanation:

Acceleration of the magnet will not be equal to g . It will be less than g . This is because, as the magnet falls, amount of magnetic flux linked with the ring changes.

An induced emf is developed in the ring which opposes the downward motion of the magnet.

(iv) (c) Resistance of the coil.

Explanation:

The magnitude of induced emf set up in the coil does not depend upon the resistance of the coil whereas induced current set up in the coil depend upon the resistance of the coil.

(v) (d) Neither emf nor current is induced in the coil.

Explanation:

As long as a coil of metal is kept stationary in a magnetic field, even if it is non-uniform, unless it is changing with respect to time, there will be no induced emf or current in the coil.

2. Answer :

(i) (b) Eddy currents.

Explanation:

The working of speedometers is based on eddy currents.

(ii) (a) Eddy currents are produced in a steady magnetic field.

(iii) (a) Laminating core.

Explanation:

To reduce the eddy currents in the metal armature of motors, wire is wrapped around a number of thin metal sheets called lamination.

(iv) (c) Increase.

Explanation:

Eddy currents also oppose the change in magnetic flux, so their direction is given by Lenz's law.

(v) (c) Henry.



C V RAMAN
P U C O L L E G E
I N D I

CHAPTER 7: ALTERNATING CURRENT

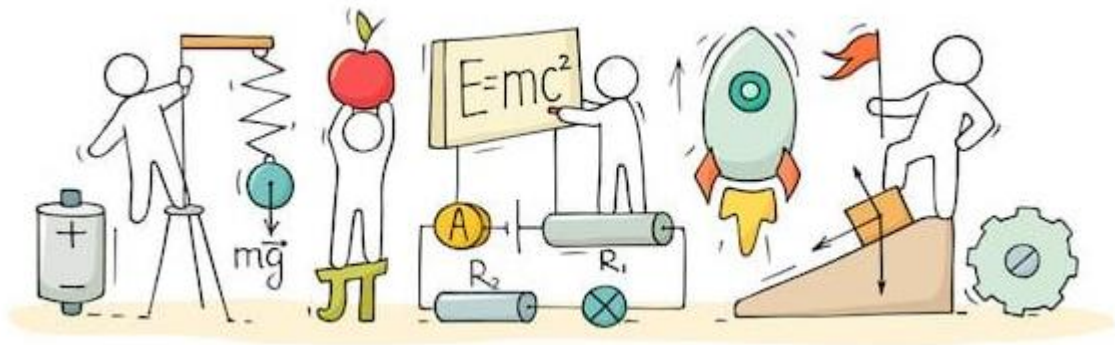

ALTERNATING CURRENT

Alternating Current:

The magnitude of alternating current changes continuously with time and its direction is reversed periodically. It is represented by

$$I = I_0 \sin \omega t \text{ or } I = I_0 \cos \omega t$$

$$\omega = \frac{2\pi}{T} = 2\pi\nu$$

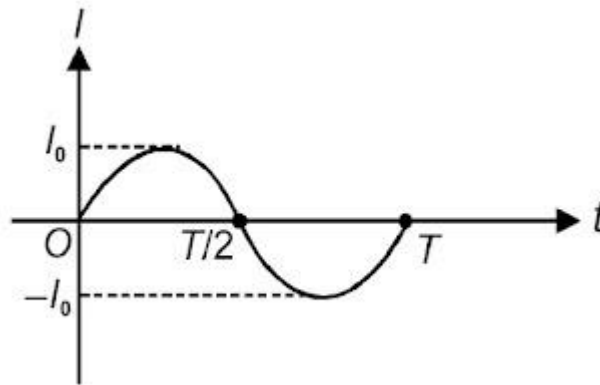

Direct current (DC):

Direct current (DC) is electrical current which flows consistently in one direction. The current that flows in a flashlight or another appliance running on batteries is direct current.

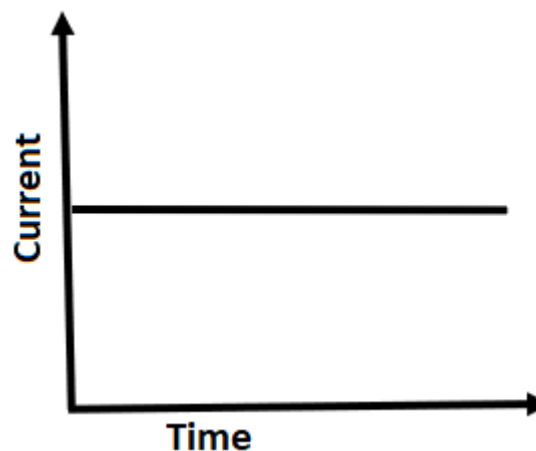

Mean value for half cycle of AC:

Mean value of AC is the total charge that flows through a circuit element in a given time interval divided by the time interval.

$$I_{\text{mean}} = \frac{\int_0^T I dt}{T}$$

For half cycle

$$I_{\text{mean}} = \frac{\int_0^{\frac{T}{2}} I dt}{\frac{T}{2}}$$

$$I_{\text{mean}} = \frac{2}{T} \int_0^{\frac{T}{2}} I_0 \sin \omega t dt$$

$$I_{\text{mean}} = \frac{2I_0}{T} \left[\frac{-\cos \omega t}{\omega} \right]_0^{\frac{T}{2}}$$

$$I_{\text{mean}} = \frac{2I_0}{2\pi} [-\cos \pi - \cos 0] \dots (\because \omega = \frac{2\pi}{T})$$

$$I_{\text{mean}} = \frac{2I_0}{\pi}$$

Note: For complete cycle, mean value = 0

Phasor Diagram:

In the a.c. circuit containing R only, current and voltage are in the same phase. Therefore, in figure, both phasors \vec{I}_0 and \vec{E}_0 are in the same direction making an angle (ωt) with OX. This is so for all times. It means that the phase angle between alternating voltage and current through R is Zero.

$$I = I_0 \sin \omega t \text{ and } E = E_0 \sin \omega t$$

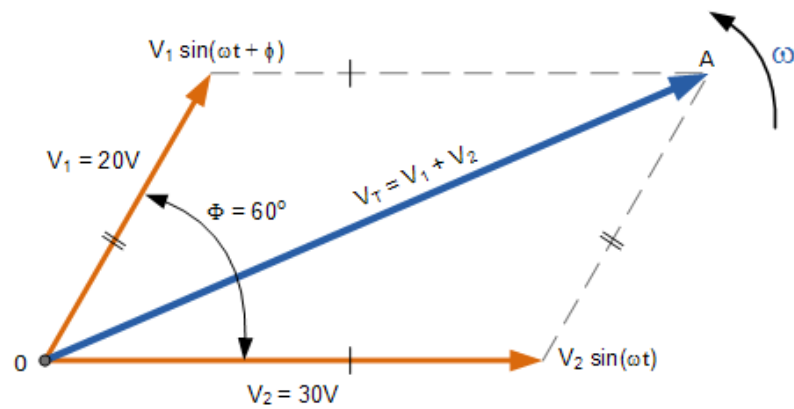

Parts of a Single-phase Transformer

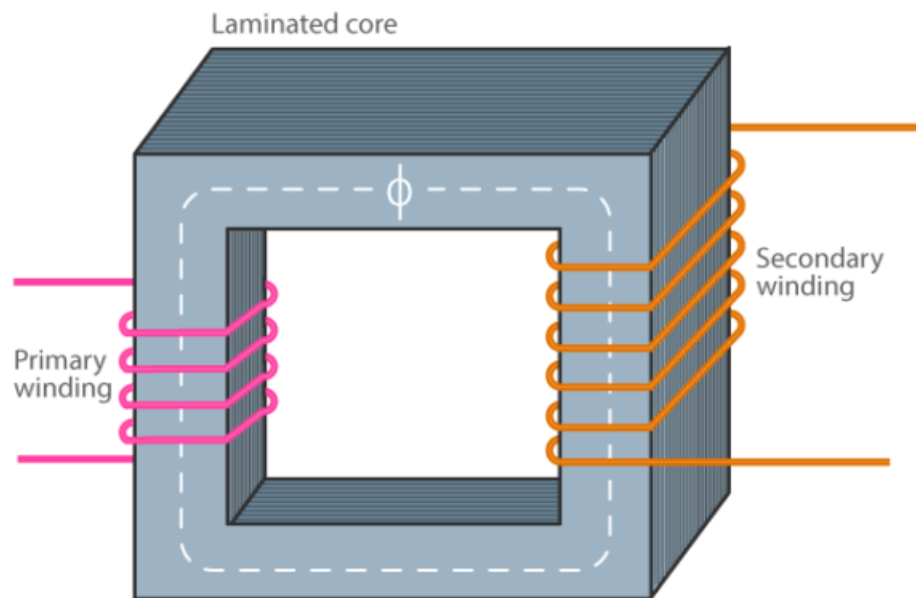

The major parts of a single-phase transformer consist of;

Core

The core acts as a support to the winding in the transformer. It also provides a low reluctance path to the flow of magnetic flux. The winding is wound on the core as shown in the picture. It is made up of a laminated soft iron core in order to reduce the losses in a transformer. The factors such as operating voltage, current, power etc decide core composition. The core diameter is directly proportional to copper losses and inversely proportional to iron losses.

Windings

Windings are the set of copper wires wound over the transformer core. Copper wires are used due to:

- The high conductivity of copper minimizes the loss in a transformer because when the conductivity increases, resistance to current flow decreases.

- The high ductility of copper is the property of metals that allows it to be made into very thin wires.

There are mainly two types of windings. Primary windings and secondary windings.

- **Primary winding:** The set of turns of windings to which supply current is fed.
- **Secondary winding:** The set of turns of winding from which output is taken.

The primary and secondary windings are insulated from each other using insulation coating agents.

Insulation Agents

Insulation is necessary for transformers to separate windings from each other and to avoid short circuit. This facilitates mutual induction. Insulation agents have an influence on the durability and the stability of a transformer.

Following are used as an insulation medium in a transformer:

- Insulating oil
- Insulating tape
- Insulating paper
- Wood-based lamination

Capacitive Reactance (X_C):

The opposing nature of capacitor to the flow of alternating current is called capacitive reactance.

$$X_C = \frac{1}{\omega C} = \frac{1}{2\pi f c}$$

Where, C = capacitance

Choke Coil:

A choke coil is an inductor having a small resistance. It is a device used in ac circuits to control current without wasting too much power. As it has low resistance, its power factor $\cos \phi$ is low.

Wattless Current:

The current in an AC circuit when average power consumption in AC circuit is zero, is referred as wattless current or idle current.

A.C. Generator or A.C. Dynamo:

An a.c. generator/dynamo is a machine that produces alternating current energy from mechanical energy. It is one of the most important applications of the phenomenon of electromagnetic induction. The generator was designed originally by a Yugoslav scientist, Nikola Tesla. The word generator is a misnomer because nothing is generated by the machine. In fact, it is an alternator converting one form of energy into another.

Transformer:

A transformer which increases the a.c. voltage is called a step-up transformer. A transformer which decreases the a.c. voltages are called a step-down transformer.

Step Up Transformer

If the secondary coil has more numbers of turns than the primary, the voltage is seen to step up, that is how the name is given for this type of transformer. If the secondary coil has less number of coils, it is referred to as a step-down type of transformer.

Transformer Types

Transformers are used in various fields like power generation grid, distribution sector, transmission and electric energy consumption. There are various types of transformers which are classified based on the following factors;

- Working voltage range.
- The medium used in the core.
- Winding arrangement.
- Installation location.

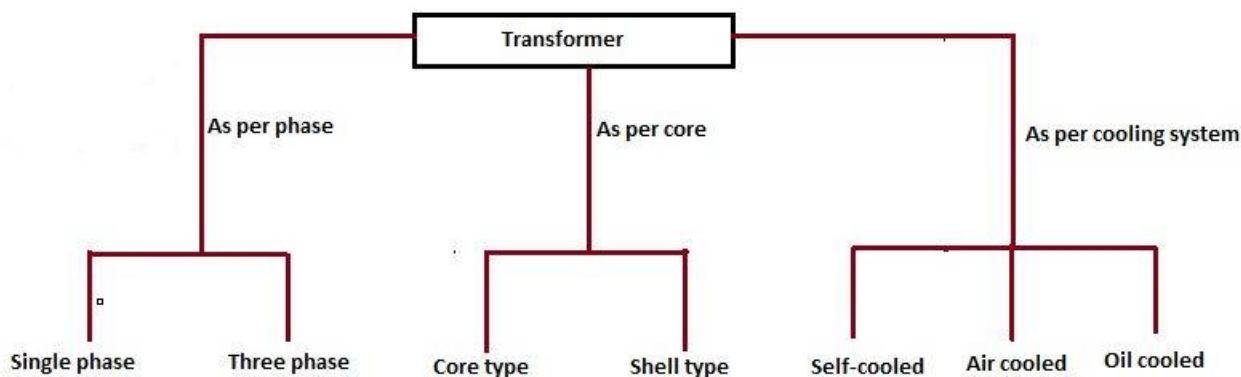

Based on Voltage Levels

Commonly used transformer type, depending upon voltage they are classified as:

Step-up Transformer: They are used between the power generator and the power grid. The secondary output voltage is higher than the input voltage.

Step down Transformer: These transformers are used to convert high voltage primary supply to low voltage secondary output.

Based on the Medium of Core Used

In a transformer, we will find different types of cores that are used.

Air core Transformer: The flux linkage between primary and secondary winding is through the air. The coil or windings wound on the non-magnetic strip.

Iron core Transformer: Windings are wound on multiple iron plates stacked together, which provides a perfect linkage path to generate flux.

Based on the Winding Arrangement

Autotransformer: It will have only one winding wound over a laminated core. The primary and secondary share the same coil. Auto also means “self” in language Greek.

Based on Install Location

Power Transformer: It is used at power generation stations as they are suitable for high voltage application

Distribution Transformer: Mostly used at distribution lanes for domestic purposes. They are designed for carrying low voltages. It is very easy to install and characterized by low magnetic losses.

Measurement Transformers: These are further classified. They are mainly used for measuring voltage, current, power.

Protection Transformers: They are used for component protection purposes. In circuits, some components must be protected from voltage fluctuation etc. Protection transformers ensure component protection.

TRANSFORMER WORKING

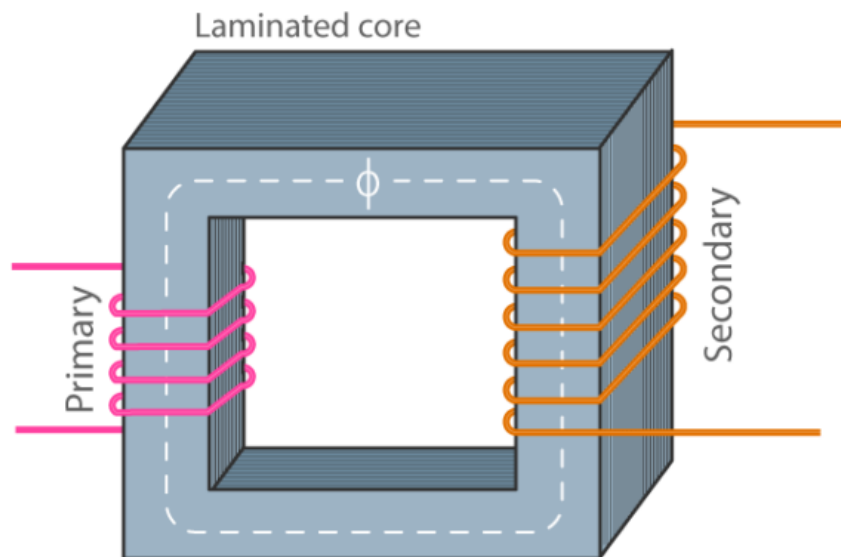

The transformer works on the principle of Faraday's law of electromagnetic induction and mutual induction.

There are usually two coils primary coil and secondary coil on the transformer core. The core laminations are joined in the form of strips. The two coils have high mutual inductance. When an alternating current pass through the primary coil it creates a varying magnetic flux. As per faraday's law of electromagnetic induction, this change in magnetic flux induces an emf (electromotive force) in the secondary coil which is linked to the core having a primary coil. This is mutual induction.

Overall, a transformer carries the below operations:

- Transfer of electrical energy from circuit to another
- Transfer of electrical power through electromagnetic induction
- Electric power transfer without any change in frequency
- Two circuits are linked with mutual induction

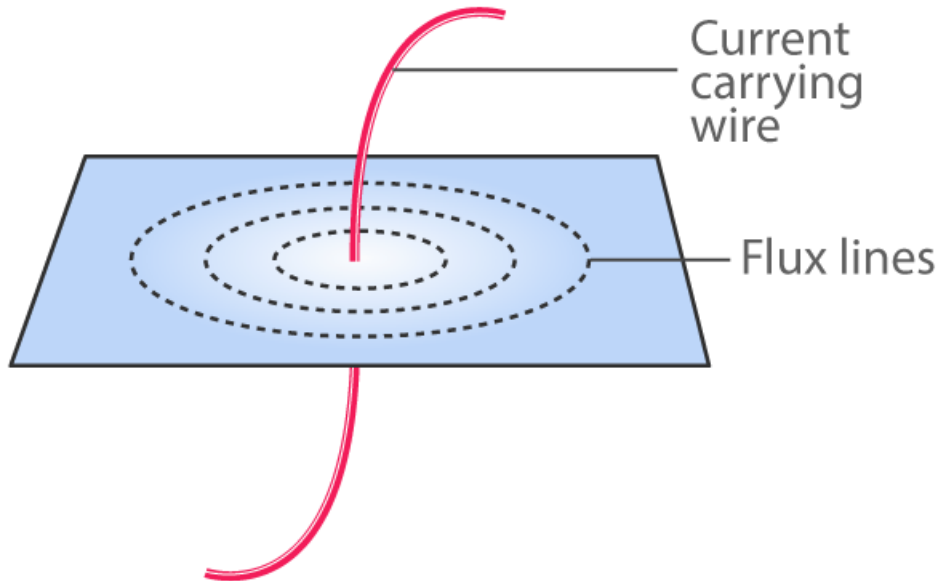

The figure shows the formation of magnetic flux lines around a current-carrying wire. The normal of the plane containing the flux lines are parallel to normal of a cross-section of a wire.

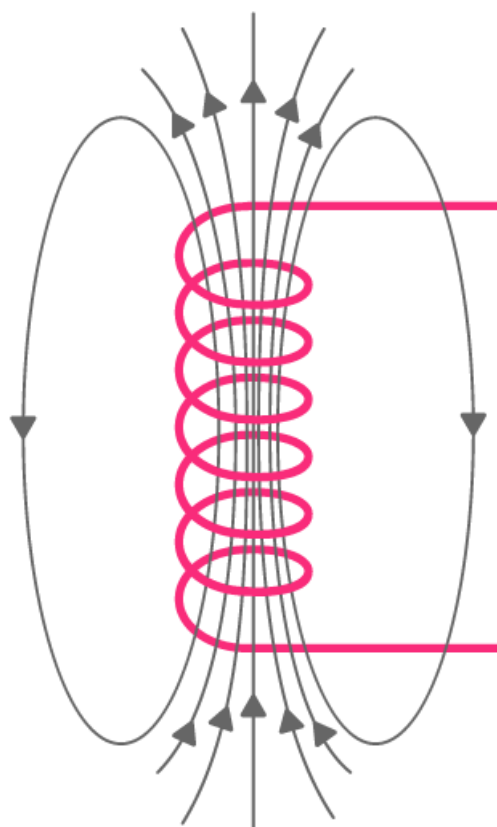

The figure shows the formation of varying magnetic flux lines around a wire-wound. The interesting part is that reverse is also true, when a magnetic flux line fluctuates around a piece of wire, a current will be induced in it. This was what Michael Faraday found in 1831 which is the fundamental working principle of electric generators as well as transformers.

Charging and Discharging of a Capacitor:

The instantaneous charge on a capacitor on charging at any instant of time t is given by

$$q = q_0 \left(1 - e^{-\frac{t}{RC}} \right)$$

where $RC = \tau$, is called time constant of a R – C circuit.

The instantaneous charge on a capacitor in discharging at any instant of time t is given by

$$q = q_0 e^{-\frac{t}{RC}}$$

Time constant of a R – C circuit is the time in which charge in the capacitor grows to 63.8% or decays to 36.8% of the maximum charge on capacitor.

Transient Current: An electric current which varies for a small finite time, while growing from zero to maximum or decaying from maximum to zero, is called a transient current.

Differences between Alternating Current and Direct Current:

Alternating Current	Direct Current
AC is safe to transfer longer distance even between two cities and maintain the electric power.	DC cannot travel for a very long distance. It loses electric power.
The rotating magnets cause the change in direction of electric flow.	The steady magnetism makes DC flow in a single direction.
The frequency of AC is dependent upon the country. But generally, the frequency is 50 Hz or 60 Hz.	DC has no frequency of zero frequency.
In AC the flow of current changes its direction backwards periodically.	It flows in a single direction steadily.
Electrons in AC keep changing its directions – backward and forward	Electrons only move in one direction – that is forward.

Use of Transformers in Transmission:

- **In electric power** transmission, transformers allow transmission of electric power at high voltages, which reduces the loss due to heating of the wires.
- In many **electronic devices**, a transformer is used to convert voltage from the distribution wiring to convenient values for the circuit requirements.
- **Signal and audio** transformers are used to couple stages of amplifiers and to match devices such as microphones and record players to the input of amplifiers.
- **Audio transformers** allowed telephone circuits to carry on a two-way conversation over a single pair of wires.
- **Resonant transformers** are used for coupling between stages of radio receivers, or in high-voltage Tesla coils.

Class : 12th Physics
Chapter - 7 : Alternating Current

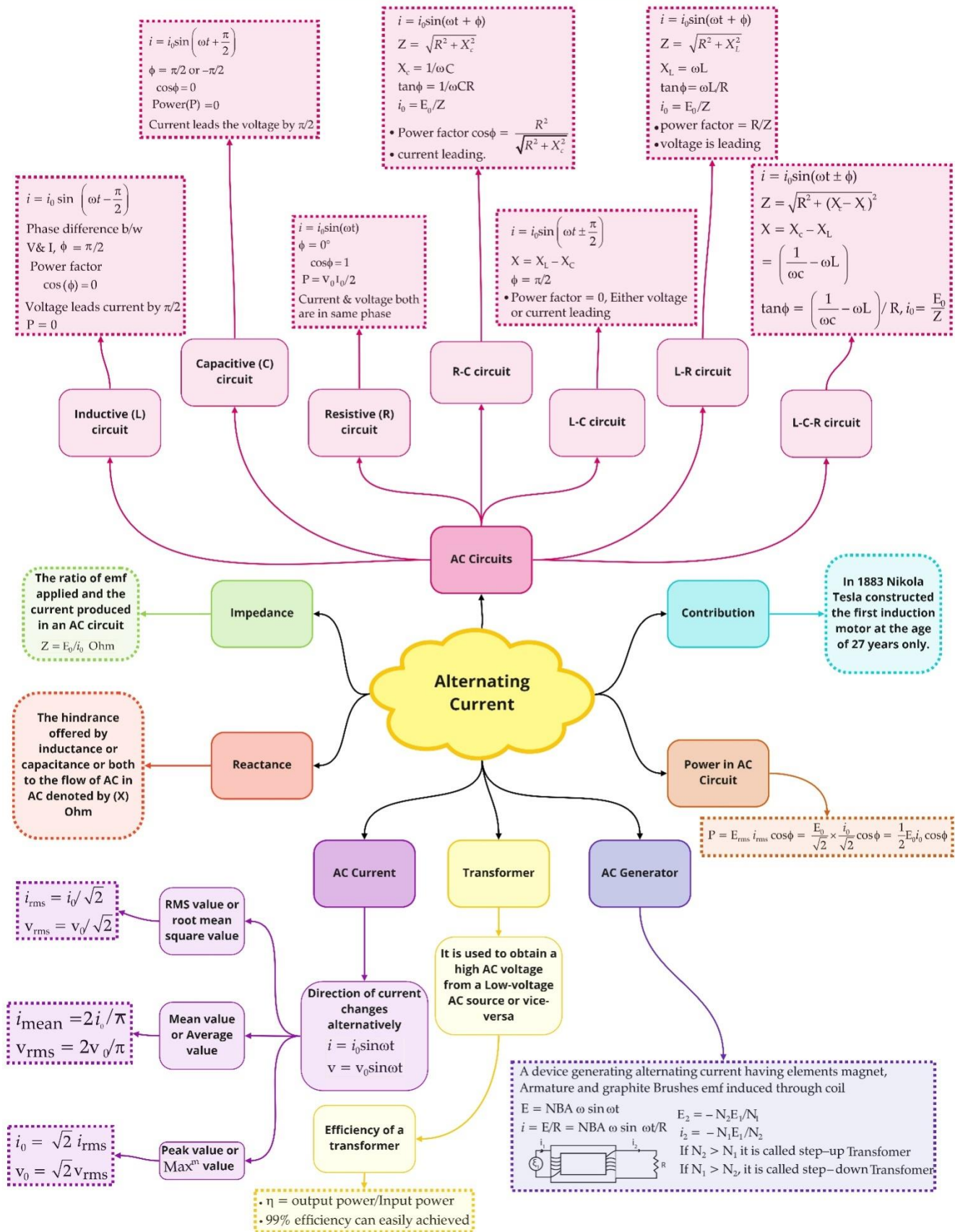

Important Questions

Multiple Choice questions-

1. Alternating voltage (V) is represented by the equation

- (a) $V(t) = V_m e^{\omega t}$
- (b) $V(t) = V_m \sin \omega t$
- (c) $V(t) = V_m \cot \omega t$
- (d) $V(t) = V_m \tan \omega t$

2. The rms value of potential difference V shown in the figure is

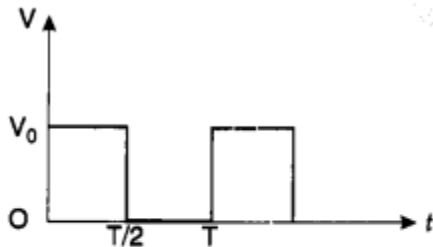

- (a) $\frac{V_0}{\sqrt{3}}$
- (b) V_0
- (c) $\frac{V_0}{\sqrt{2}}$
- (d) $\frac{V_0}{2}$

3. The phase relationship between current and voltage in a pure resistive circuit is best represented by

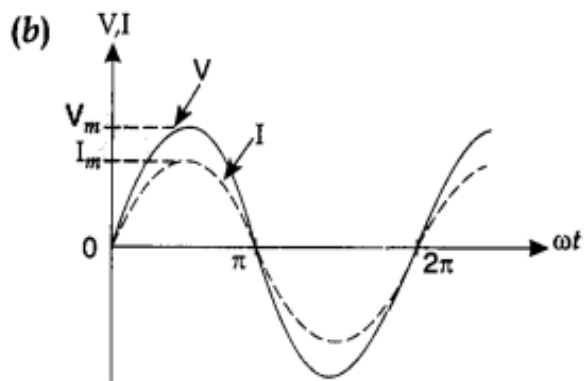
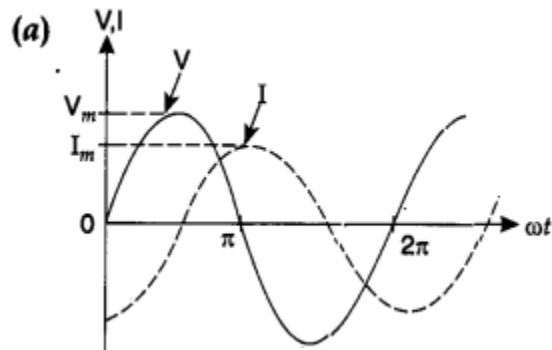

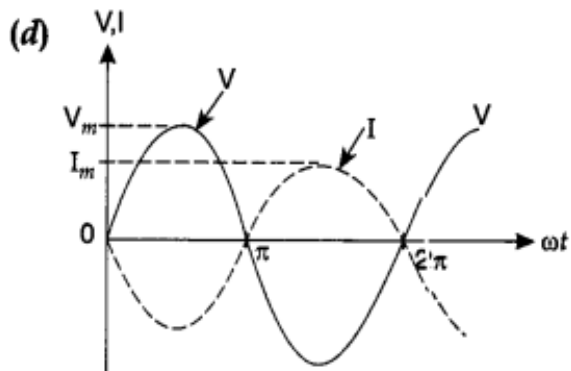
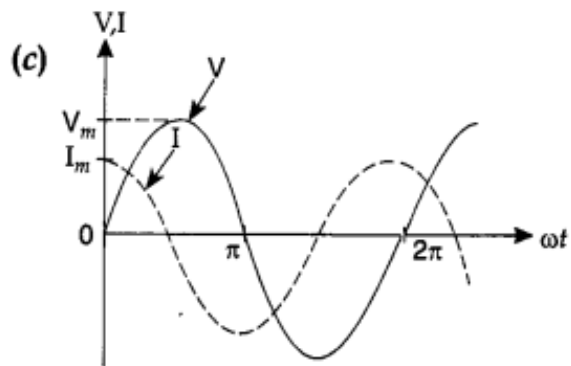

4. In the case of an inductor

- (a) voltage lags the current by $\frac{\pi}{2}$
- (b) voltage leads the current by $\frac{\pi}{2}$
- (c) voltage leads the current by $\frac{\pi}{3}$
- (d) voltage leads the current by $\frac{\pi}{4}$

5. Which of the following graphs represents the correct variation of inductive reactance X_L with frequency ν ?

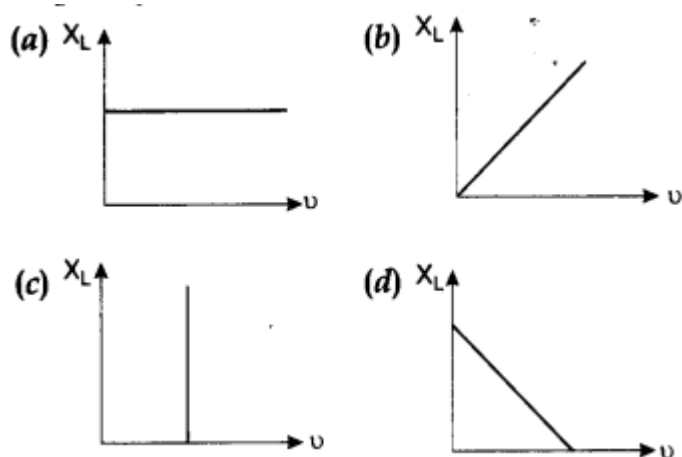

6. In a pure capacitive circuit if the frequency of ac source is doubled, then its capacitive reactance will be

- (a) remains same
- (b) doubled
- (c) halved
- (d) zero

7. Which of the following graphs represents the correct variation of capacitive reactance X_c with frequency ν u?

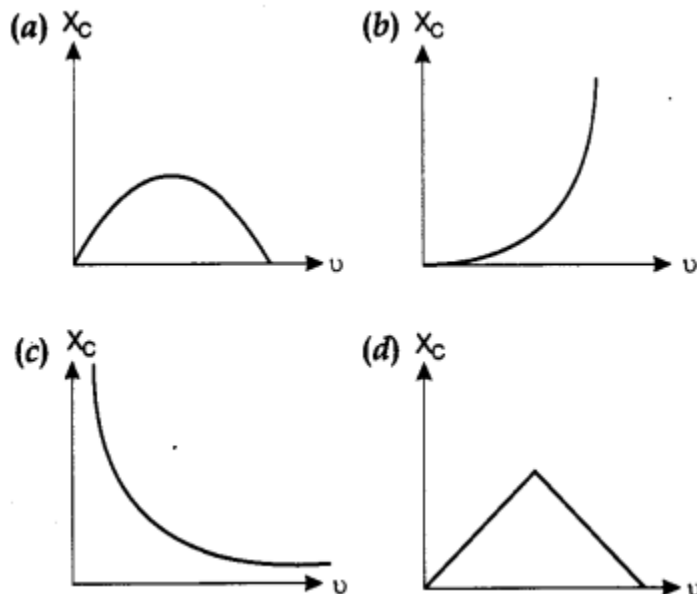

8. In an alternating current circuit consisting of elements in series, the current increases on increasing the frequency of supply. Which of the following elements are likely to constitute the circuit?

- (a) Only resistor
- (b) Resistor and inductor
- (c) Resistor and capacitor
- (d) Only inductor

9. In which of the following circuits the maximum power dissipation is observed?

- (a) Pure capacitive circuit
- (b) Pure inductive circuit
- (c) Pure resistive circuit
- (d) None of these

10. In series LCR circuit, the phase angle between supply voltage and current is

- (a) $\tan \phi = \frac{X_L - X_C}{R}$
- (b) $\tan \phi = \frac{R}{X_L - X_C}$
- (c) $\tan \phi = \frac{R}{X_L + X_C}$
- (d) $\tan \phi = \frac{X_L + X_C}{R}$

Very Short:

1. The instantaneous current flowing from an ac source is $I = 5 \sin 314 t$. What is the rms value of current?
2. The instantaneous emf of an ac source is given by $E = 300 \sin 314 t$. What is the rms value of emf?
3. Give the phase difference between the applied ac voltage and the current in an LCR circuit at resonance.
4. What is the phase difference between the voltage across the inductor and the capacitor in an LCR circuit?
5. What is the power factor of an LCR series circuit at resonance?
6. In India, the domestic power supply is at 220 V, 50 Hz, while in the USA it is 110 V, 50 Hz. Give one advantage and one disadvantage of 220 V supply over 110 V supply.
7. Define the term 'wattless current'. (CBSE Delhi 2011)
8. In a series LCR circuit, $V_L = V_C \neq V_R$. What is the value of the power factor? (CBSE AI 2015)
9. Define capacitor reactance. Write its SI units. (CBSE Delhi 2015)
10. Define quality factor in series LCR circuit. What is its SI unit? (CBSE Delhi 2016)

Short Questions:

1. State the phase relationship between the current flowing and the voltage applied in an ac circuit for (i) a pure resistor (ii) a pure inductor.
2. A light bulb is in turn connected in a series (a) across an LR circuit, (b) across an RC circuit, with an ac source. Explain, giving the necessary mathematical formula, the effect on the brightness of the bulb in case (a) and (b), when the frequency of the ac source is increased. (CBSE 2019C)
3. An air-core solenoid is connected to an ac source and a bulb. If an iron core is inserted in the solenoid, how does the brightness of the bulb change? Give reasons for your answer.
4. A bulb and a capacitor are connected in series to an ac source of variable frequency. How will the brightness of the bulb change on increasing the frequency of the ac source? Give reason.
5. An ideal inductor is in turn put across 220 V, 50 Hz, and 220 V, 100 Hz supplies. Will the current flowing through it in the two cases be the same or different?
6. State the condition under which the phenomenon of resonance occurs in a series LCR circuit, plot a graph showing the variation of current with a frequency of ac source in a series LCR circuit.

7. Give two advantages and two disadvantages of ac over dc.
8. In a series, LCR circuit connected to an ac source of variable frequency and voltage $v = v_m \sin \omega t$, draw a plot showing the variation of current (I) with angular frequency (ω) for two different values of resistance R_1 and R_2 ($R_1 > R_2$). Write the condition under which the phenomenon of resonance occurs. For which value of the resistance out of the two curves, a sharper resonance is produced? Define the Q-factor of the circuit and give its significance. (CBSE Delhi 2013C)

Long Questions:

1. Prove mathematically that the average power over a complete cycle of alternating current through an Ideal inductor is zero.
2. Draw the phasor diagram of a series LCR connected across an ac source $V = V_0 \sin \omega t$. Hence, derive the expression for the impedance of the circuit. Obtain the conditions for the phase angle under which the current is
 - (i) maximum and
 - (ii) minimum. (CBSE AI 2019)

Assertion and Reason Question:

1. For two statements are given-one labelled Assertion (A) and the other labelled Reason (R). Select the correct answer to these questions from the codes (a), (b), (c) and (d) as given below.

- a) Both A and R are true and R is the correct explanation of A.
- b) Both A and R are true but R is not the correct explanation of A.
- c) A is true but R is false.
- d) A is false and R is also false.

Assertion: A bulb connected in series with a solenoid is connected to A.C. source. If a soft iron core is introduced in the solenoid, the bulb will glow brighter.

Reason: On introducing soft iron core in the solenoid, the inductance decreases.

2. For two statements are given-one labelled Assertion (A) and the other labelled Reason (R). Select the correct answer to these questions from the codes (a), (b), (c) and (d) as given below.

- a) Both A and R are true and R is the correct explanation of A.
- b) Both A and R are true but R is not the correct explanation of A.
- c) A is true but R is false.
- d) A is false and R is also false.

Assertion: An alternating current shows magnetic effect.

Reason: Magnitude of alternating current varies with time.

Case Study Questions:

1. Step-down transformers are used to decrease or step-down voltages. These are used when voltages need to be lowered for use in homes and factories. A small town with a demand of 800kW of electric power at 220V is situated 15km away from an electric plant generating power at 440V. The resistance of the two wire line carrying power is 0.5Ω per km. The town gets power from the line through a 4000 - 220V step-down transformer at a sub-station in the town.

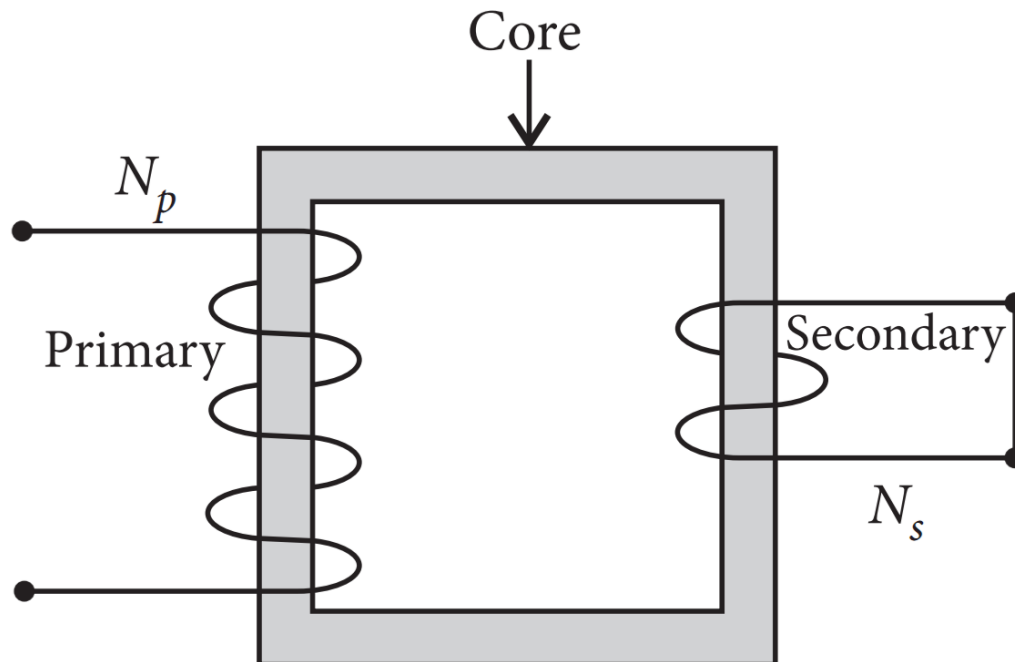

(i) The value of total resistance of the wires is:

- a) 25Ω
- b) 30Ω
- c) 35Ω
- d) 15Ω

(ii) The line power loss in the form of heat is:

- a) 550kW
- b) 650kW
- c) 600kW
- d) 700kW

(iii) How much power must the plant supply, assuming there is negligible power loss due to leakage?

- a) 600kW
- b) 1600kW
- c) 500W
- d) 1400kW

(iv) The voltage drop in the power line is:

- a) 1700V
- b) 3000V
- c) 2000V
- d) 2800V

(v) The total value of voltage transmitted from the plant is:

- a) 500V
- b) 4000V
- c) 3000V
- d) 7000V

2. When the frequency of ac supply is such that the inductive reactance and capacitive reactance become equal, the impedance of the series LCR circuit is equal to the ohmic resistance in the circuit. Such a series LCR circuit is known as resonant series LCR circuit and the frequency of the ac supply is known as resonant frequency. Resonance phenomenon is exhibited by a circuit only if both L and C are present in the circuit. We cannot have resonance in a RL or RC circuit.

A series LCR circuit with $L = 0.12\text{H}$, $C = 480\text{nF}$, $R = 23\Omega$ is connected to a 230V variable frequency supply.

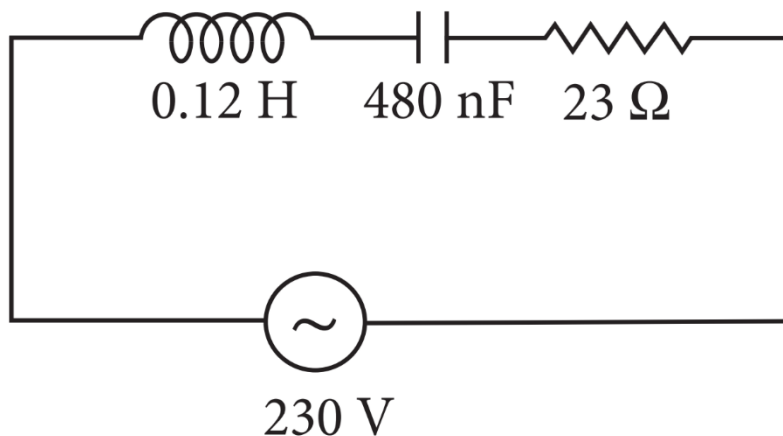

(i) Find the value of source frequency for which current amplitude is maximum.

- a) 222.32Hz
- b) 550.52Hz
- c) 663.48Hz
- d) 770Hz

(ii) The value of maximum current is:

- a) 14.14A
- b) 22.52A
- c) 50.25A
- d) 47.41A

(iii) The value of maximum power is:

- a) 2200W
- b) 2299.3W
- c) 5500W
- d) 4700W

(iv) What is the Q-factor of the given circuit?

- a) 25
- b) 42.21
- c) 35.42
- d) 21.74

(v) At resonance which of the following physical quantity is maximum?

- a) Impedance
- b) Current
- c) Both (a) and (b)
- d) Neither (a) nor (b)

✓ Answer Key:

Multiple Choice Answers-

1. Answer: b
2. Answer: c
3. Answer: b
4. Answer: b
5. Answer: b
6. Answer: c
7. Answer: c
8. Answer: c
9. Answer: c
10. Answer: a

Very Short Answers:

1. Answer:

The rms value of current is $\frac{5}{\sqrt{2}}$.

2. Answer:

The rms value of voltage is $\frac{300}{\sqrt{2}}$

3. Answer:

The applied ac voltage and the current in an LCR circuit at resonance are in phase.

Hence phase difference = 0.

4. Answer: The phase difference is 180° .

5. Answer: The power factor is one.

6. Answer:

Advantage: less power losses

Disadvantage: more fatal.

7. Answer: It is the current at which no power is consumed.

8. Answer: One.

9. Answer: It is the opposition offered to the flow of current by a capacitor. It is measured in ohm.

10. Answer: The quality factor is defined as the ratio of the voltage developed across the capacitor or inductor to the applied voltage. It does not have any unit.

Short Questions Answers:

1. Answer:

(i) Electric current and voltage applied in a pure resistor are in same phase, i.e. $\Phi = 0^\circ$

(ii) Applied voltage leads electric current flowing through pure-inductor in an ac circuit by phase angle of $\pi/2$.

2. Answer:

a) The current in LR circuit is given by

$$I = \frac{V}{\sqrt{R^2 + \omega^2 L^2}}$$

When the frequency of ac source ω increases, I decreases, and hence brightness decreases.

(b) The current in RC circuit is given by

$$I = \frac{V}{\sqrt{R^2 + \frac{1}{\omega^2 C^2}}}$$

When the frequency of ac source ω increases, I increases, and hence brightness increases.

3. Answer: Insertion of an iron core in the solenoid increases its inductance. This in turn increases the value of inductive reactance. This decreases the current and hence the brightness of the bulb.

4. Answer:

When the frequency of the ac is increased, it will decrease the impedance of the circuit as $Z = \sqrt{R^2 + (1/2\pi fC)^2}$. As a result, the current and hence the brightness of the bulb will increase.

5. Answer:

The current through the inductor is given by $I = \frac{V}{X_L} = \frac{V}{2\pi fL}$. The current is inversely proportional to the frequency of applied ac.

6. Answer: The phenomenon occurs when the inductive reactance becomes equal to the capacitive reactance., i.e., $X_L = X_C$

$$\Rightarrow \omega L = \frac{1}{\omega C}$$

$$\Rightarrow \omega = \frac{1}{\sqrt{LC}}$$

The graph is as shown below.

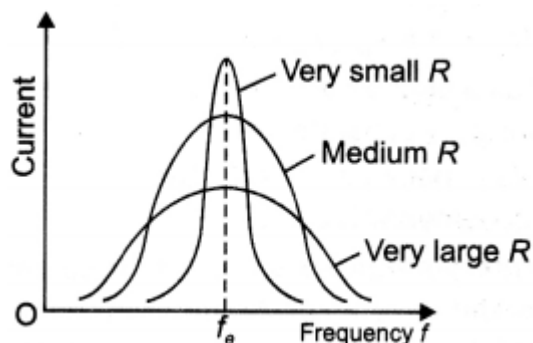

7. Answer:

Advantages of ac:

- The generation and transmission of ac are more economical than dc.
- The alternating voltage may be easily stepped up or down as per need by using suitable transformers.

Disadvantages of ac:

- It is more fatal than dc.
- It cannot be used for electrolysis.

8. Answer:

The plot is as shown.

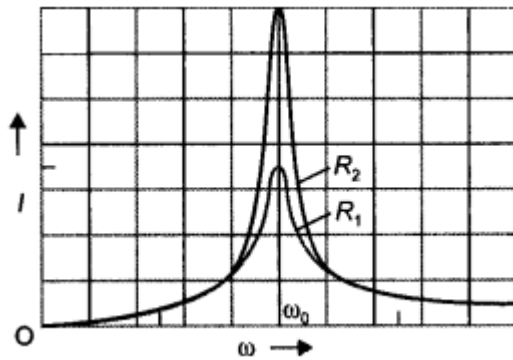

Resonance occurs in an LCR circuit when

$$X_L = X_C.$$

The smaller the value of R sharper is the resonance. Therefore, the curve will be sharper for R_2 . It determines the sharpness of the resonance. The larger the value of Q sharper is the resonance.

Long Questions Answers:

1. Answer:

Let the instantaneous value of voltage and current in the ac circuit containing a pure inductor are

$$V = V_m \sin \omega t \text{ and}$$

$$I = I_m \sin (\omega t - \pi/2) = -I_m \cos \omega t$$

where $\pi/2$ is the phase angle by which voltage leads current when ac flows through an inductor. Suppose the voltage and current remain constant for a small-time dt . Therefore, the electrical energy consumed in the small-time dt is

$$dW = V I dt$$

The total electrical energy consumed in one time period of ac is given by

$$W = \int_0^T VI dt = -\int_0^T V_m \sin \omega t \cdot I_m \cos \omega t dt$$

$$= -V_m I_m \int_0^T \sin \omega t \cos \omega t dt$$

$$\text{or } W = -\frac{I_m V_m}{2} \int_0^T 2 \sin \omega t \cos \omega t dt$$

$$\text{or } W = -\frac{I_m V_m}{2} \int_0^T \sin 2\omega t dt$$

$$\text{or } W = -\frac{I_m V_m}{2} \left[-\frac{\cos(2\omega t)}{2\omega} \right]_0^T = 0$$

Therefore, the total electrical energy consumed in an ac circuit by a pure inductor is $W = 0$

Now average power is defined as the ratio of the total electrical energy consumed over the entire cycle to the time period of the cycle, therefore

$$P_{av} = \frac{W}{T} = 0$$

Hence, the average power consumed in an ac circuit by a pure inductor is $P_{av} = 0$

Thus, a pure inductor does not consume any power when ac flows through it. Whatever energy is used in building up current is returned during the decay of current.

2. Answer:

The voltages across the various elements are drawn as shown in the figure below.

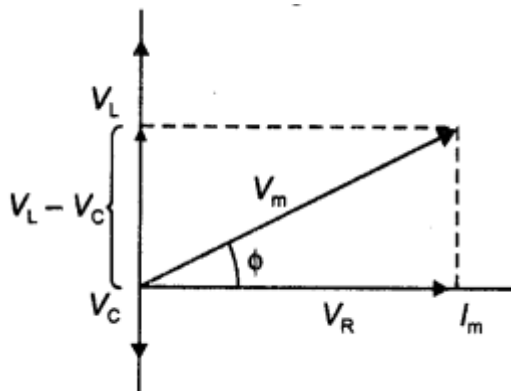

From the diagram, we observe that the vector sum of the voltage amplitudes V_R , V_L , and V_C equals a phasor whose length is the maximum applied voltage V_m ,

where the phasor V_m makes an angle ϕ with the current phasor I_m . Since the voltage phasors, V_L and V_C are in opposite direction, therefore, a difference phasor ($V_L - V_C$) is drawn which is perpendicular to the phasor V_R . Adding vectorially we have

$$V_m = \sqrt{V_R^2 + (V_L - V_C)^2}$$

$$= \sqrt{(I_m R)^2 + (I_m X_L - I_m X_C)^2}$$

$$\text{or } V_m = I_m \sqrt{R^2 + (X_L - X_C)^2}$$

where $X_L = \omega L$ and $X_C = 1 / \omega C$, therefore, we can express the maximum current as

$$I_m = \frac{V_m}{\sqrt{R^2 + (X_L - X_C)^2}}$$

The impedance Z of the circuit is defined as $Z = \sqrt{R^2 + (X_L - X_C)^2}$

For maximum I_m , Z should be minimum ($Z = R$) or $X_C = X_L = 0$ and $\Phi = 0$

For $(I_m)_{\min}$ $\Phi \rightarrow 90^\circ$ ($|X_C - X_L| \gg R$) $Z \rightarrow \infty$

Assertion and Reason Answers:

1. (d) A is false and R is also false.

Explanation:

On introducing soft iron core, the bulb will glow dimmer. This is because on introducing soft iron core in the solenoid, its inductance L increases, the inductive reactance, $X_L = \omega L$ increases and hence the current through the bulb decreases.

2. (b) Both A and R are true but R is not the correct explanation of A.

Explanation:

Like direct current, an alternating current also produces magnetic field. But the magnitude and direction of the field goes on changing continuously with time.

Case Study Answers:

1. Answer :

(i) (d) 15Ω

Explanation:

Resistance of the two wire lines carrying power = $0.5 \frac{\Omega}{\text{Km}}$

$$\text{Total resistance} = (15 + 15)0.5 = 15\Omega$$

(ii) (c) 600kW

Explanation:

$$\text{Line power loss} = I^2R$$

RMS current in the coil,

$$I = \frac{P}{V_1} = \frac{800 \times 10^3}{4000} = 200\text{A}$$

$$\therefore \text{Power loss} = (200)^2 \times 15 = 600\text{kW}$$

(iii) (d) 1400kW

Explanation:

Assuming that the power loss is negligible due to the leakage of the current.

The total power supplied by the plant,

$$= 800\text{kW} + 600\text{kW} = 1400\text{kW}$$

(iv) (b) 3000V

Explanation:

$$\text{Voltage drop in the power line} = IR$$

$$= 200 \times 15 = 3000\text{V}$$

(v) (d) 7000V

Explanation:

Total voltage transmitted from the plant,

$$= 3000\text{V} + 4000\text{V} = 7000\text{V}$$

2. Answer :

i. (c) 663.48Hz

Explanation:

Here, $L = 0.12\text{H}$, $e = 480\text{nF} = 480 \times 10^{-9}\text{F}$

$$R = 23\Omega, v = 230\text{V}$$

$$V_0 = \sqrt{2} \times 230 = 325.22\text{V}$$

$$I_0 = \frac{V_0}{\sqrt{R^2 + \left(\omega L - \frac{1}{\omega C}\right)^2}}$$

$$\text{At resonance, } \omega L - \frac{1}{\omega C} = 0$$

$$\omega = \frac{1}{\sqrt{LC}} = \frac{1}{\sqrt{0.12 \times 480 \times 10^9}} = 4166.67 \text{ rad s}^{-1}$$

$$v_R = \frac{4166.67}{2 \times 3.14} = 663.48\text{Hz}$$

ii. (a) 14.14A

Explanation:

$$\text{Current, } I_0 = \frac{V_0}{R} = \frac{325.22}{23} = 14.14\text{A}$$

iii. (b) 2299.3W

Explanation:

$$\begin{aligned} \text{Maximum power, } P_{\max} &= \frac{1}{2} (I_0)^2 R \\ &= \frac{1}{2} \times (14.14)^2 \times 23 = 2299.3\text{W} \end{aligned}$$

iv. (d) 21.74

Explanation:

$$\begin{aligned} \text{Quality factor, } Q &= \frac{X_R}{R} = \frac{\omega_r L}{R} \\ &= \frac{4166.67 \times 0.12}{23} = 21.74 \end{aligned}$$

v. (b) Current



C V RAMAN
P U C O L L E G E
I N D I

CHAPTER 8: ELECTROMAGNETIC WAVES

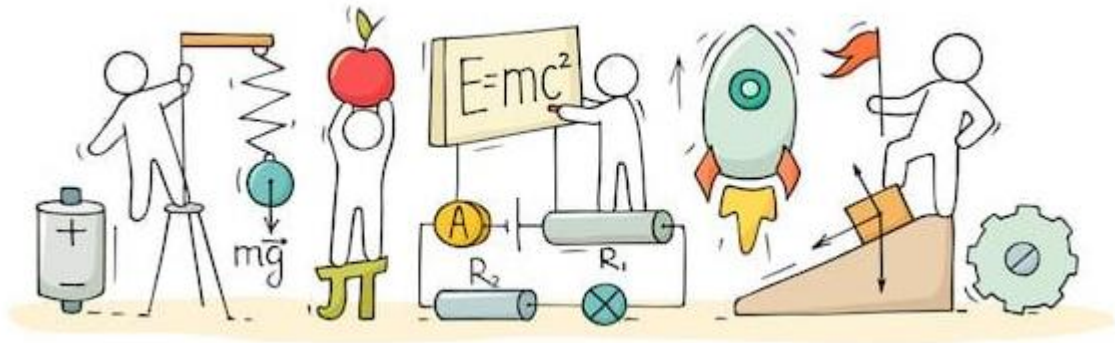

ELECTROMAGNETIC WAVES

Displacement Current:

The current which comes into play in the region in which the electric field and the electric flux is changing with time. It is given by

$$I_D = \epsilon_0 \frac{d\phi_E}{dt}$$

Ampere-Maxwell Law:

$$\oint \mathbf{B} \cdot d\mathbf{l} = \mu_0 (I + I_D)$$

Where, μ_0 = Permeability

$$= 4\pi \times 10^{-7} \text{ V / Am}$$

Maxwell's Equations:

Maxwell's equations relate electric field E and magnetic field B and their sources which are electric charges and current. In free space Maxwell's equations are as follows.

$$1. \oint \vec{E} \cdot d\vec{s} = \frac{q}{\epsilon_0}$$

This equation represents Gauss's law in electrostatics.

$$2. \oint \vec{B} \cdot d\vec{s} = 0$$

This equation is considered as Gauss's law in magnetism. It states that net magnetic flux passing through a closed surface is zero.

$$3. \oint \vec{E} \cdot d\vec{l} = \frac{d\phi}{dt}$$

This equation is Faraday's law of electromagnetic induction. This law relates electric field with changing magnetic flux.

$$4. \oint \vec{B} \cdot d\vec{l} = \mu_0 (I_c + I_d)$$

This equation represents Ampere-Maxwell's law or generalized form of Ampere's law.

Electromagnetic Waves:

An electromagnetic wave is a wave radiated by an accelerated or oscillatory charge in which varying magnetic field is the source of electric field and varying electric field is the source of magnetic field. Thus, two fields become source of each other, and the wave propagates in a direction perpendicular to both the fields.

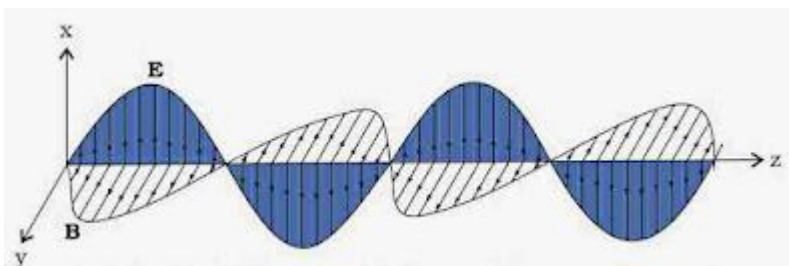

Electromagnetic waves are transverse in nature, i.e., electric and magnetic fields are perpendicular to each other and to the direction of wave propagation. Electromagnetic waves are not deflected by electric and magnetic fields.

Sources of electromagnetic waves:

1. An electric charge at rest produces only electrostatic field around it.
2. A charge moving with uniform velocity produces both electric and magnetic field, here magnetic field does not change with time hence it does not produce time varying electric field.
3. An accelerating charge produces both electric field and magnetic field which varies with space and time which forms electromagnetic wave.
4. An accelerating charge emits electromagnetic wave of same frequency as frequency of accelerating charge.
5. An electron orbiting around its nucleus in a stationary orbit does not emit electromagnetic wave. It will emit only during transition from higher energy orbit to lower energy orbit.
6. Electromagnetic wave (X-ray) is produced when high speed electron enters into target of high atomic weight.
7. Electromagnetic wave (γ -rays) is produced during de-excitation of nucleus in radioactivity.

Electromagnetic Spectrum:

The orderly distribution of electromagnetic radiations according to their frequency (or wavelength) is called electromagnetic spectrum. Maxwell predicted the existence of electromagnetic wave. Electromagnetic wave experimentally discovered by Hertz.

At the end of nineteenth century, visible light, ultraviolet, infrared, X-rays and γ -rays

had also been discovered.

We now know that electromagnetic waves include:

- γ -rays
- X-ray
- Ultraviolet rays
- Visible light
- Infrared
- Microwaves
- Radio waves.

Greenhouse Effect:

The greenhouse effect is a natural process that warms the Earth's surface. When the Sun's energy reaches the Earth's atmosphere, some of it is reflected to space and the rest is absorbed and re-radiated by greenhouse gases. Greenhouse gases include water vapour, carbon dioxide, methane, nitrous oxide, ozone, and some artificial chemicals such as chlorofluorocarbons (CFCs).

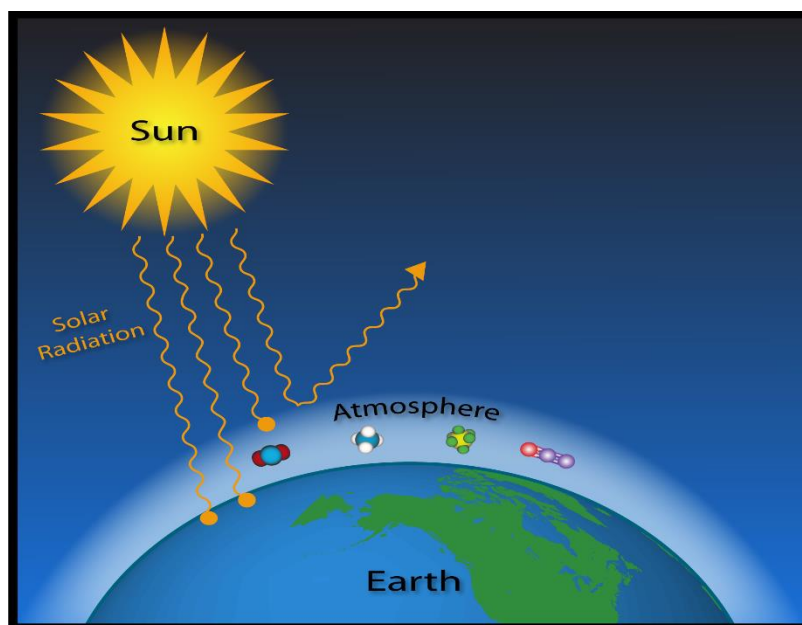

Maxwell's Experiments:

- Maxwell claimed that time-varying electric fields can generate magnetic fields.
- On the other hand, Faraday-Lenz law claims that a time varying magnetic field generates an electric field.
- According to Faraday-Lenz law, an EMF is induced in a circuit whenever the amount of magnetic flux linked with that circuit changes.

- As a result, electric current gets generated in the circuit which has an electric field associated with it.
- Now, when Maxwell came across this, he claimed that the vice-versa must also be true, i.e., a time varying electric field must also be able to generate a magnetic field.

Class : 12th Physics
Chapter- 8 : Electromagnetic Waves

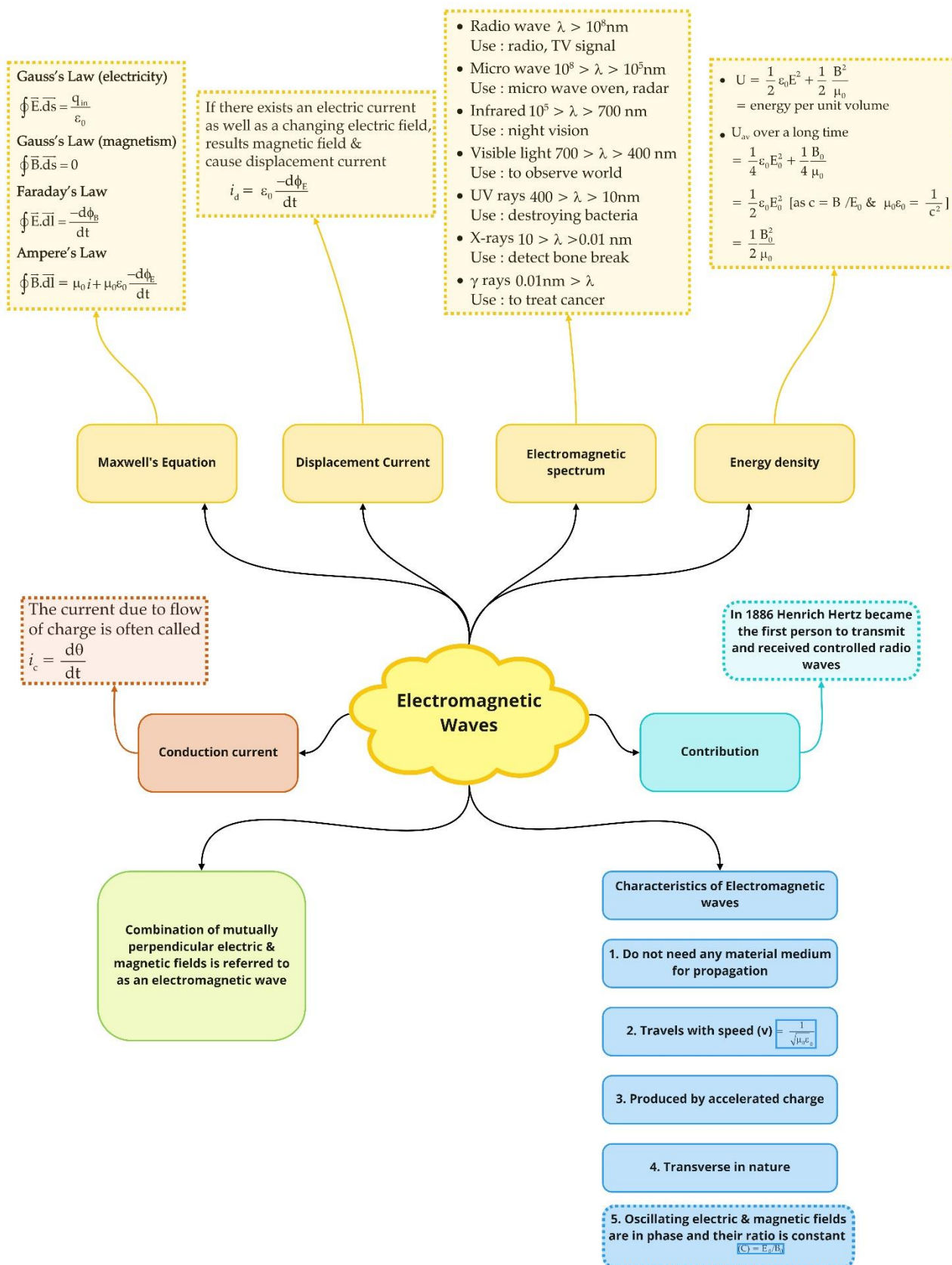

Important Questions

Multiple Choice questions-

- Maxwell in his famous equations of electromagnetism introduced the concept of
 - ac current
 - displacement current
 - impedance
 - reactance
- The conduction current is same as displacement current when source is
 - ac only
 - dc only
 - either ac or dc
 - neither dc nor ac
- If a variable frequency ac source is connected to a capacitor, then with decrease in frequency the displacement current will
 - increase
 - decrease
 - remains constant
 - first decrease then increase
- An electromagnetic wave can be produced, when charge is
 - moving with a constant velocity
 - moving in a circular orbit
 - falling in an electric field
 - both (b) and (c)
- Which of the following statement is false for the properties of electromagnetic waves?
 - Both electric and magnetic field vectors attain the maxima and minima at the same place and same time.
 - The energy in electromagnetic waves is divided equally between electric and magnetic field vectors.
 - Both electric and magnetic field vectors are parallel to each other and perpendicular to the direction of propagation of wave.

(d) These waves do not require any material medium for propagation.

6. Which of the following has/have zero average value in a plane electromagnetic wave?

(a) Both magnetic and electric fields

(b) Electric field only

(c) Magnetic field only

(d) None of these

7. A charged particle oscillates about its mean equilibrium position with a frequency of 10^9 Hz. The frequency of electromagnetic waves produced by the oscillator is

(a) 10^6 Hz

(b) 10^7 Hz

(c) 10^8 Hz

(d) 10^9 Hz

8. If E and B denote electric and magnetic fields respectively, which of the following is dimensionless?

(a) $\sqrt{\mu_0 \epsilon_0} \frac{E}{B}$

(b) $\mu_0 \epsilon_0 \frac{E}{B}$

(c) $\mu_0 \epsilon_0 \left(\frac{B}{E}\right)^2$

(d) $\frac{E \mu_0}{\epsilon_0 B}$

9. The ultra-high frequency band of radio waves in electromagnetic wave is used as in

(a) television waves

(b) cellular phone communication

(c) commercial FM radio

(d) both (a) and (c)

10. The waves used by artificial satellites for communication is

(a) microwaves

(b) infrared waves

(c) radio waves

(d) X-rays

Very Short:

1. Name the part of the electromagnetic spectrum which has the longest wavelength and write its one use. (CBSE 2019C)

2. The small ozone layer on the top of the stratosphere is crucial for human survival. Why?
3. Name the part of the electromagnetic spectrum which is used in the “greenhouse” to keep plants warm.
4. How are radio waves produced? (CBSE AI 2011)
5. How are X-rays produced? (CBSE AI 2011)
6. How are microwaves produced? (CBSE AI 2011)
7. A plane electromagnetic wave travels in a vacuum along the z-direction. What can you say about the direction of electric and magnetic field vectors? (CBSE Delhi 2011)
8. What is the frequency of electromagnetic waves produced by the oscillating charge of frequency ν ? (CBSE Delhi 2011C)
9. What are the directions of electric and magnetic field vectors relative to each other and relative to the direction of propagation of electromagnetic waves? (CBSE AI 2012)
10. Welders wear special goggles or face masks with glass windows to protect their eyes from electromagnetic radiation. Name the radiations and write the range of their frequency. (CBSE AI 2013)

Short Questions:

1. Radio waves and gamma rays both are transverse in nature and electromagnetic in character and have the same speed in a vacuum. In what respect are they different?
2. Show that the average energy density of the electric field equals the average density of the magnetic field.
3. State four properties of electromagnetic waves.
4. Electromagnetic radiations with wavelength
 - (a) λ_1 are used to kill germs in water purifiers.
 - (b) λ_2 are used in TV communication systems.
 - (c) λ_3 plays an important role in maintaining the earth’s warmth.

Name the part of the electromagnetic spectrum to which these radiations belong. Arrange these wavelengths in decreasing order of their magnitude.

5. Name the constituent radiation of the electromagnetic spectrum which
 - (a) is used in satellite communication.
 - (b) is used for studying crystal structure.

- (c) is similar to the radiations emitted during the decay of a radioactive nucleus.
- (d) is absorbed from sunlight by the ozone layer.
- (e) produces an intense heating effect.
- (f) has its wavelength range between 390 nm and 770 nm.

6. Name the radiations of the electromagnetic spectrum which are used in

- (a) warfare to look through the haze.
- (b) radar and geostationary satellites
- (c) studying the structure and properties of atoms and molecules.

7. Why are microwaves used in RADAR?

8. Electromagnetic waves with wavelength

- (a) λ_1 are used to treat muscular strain.
- (b) λ_2 are used by an FM radio station for broadcasting.
- (c) λ_3 are used to detect fractures in bones.
- (d) λ_4 are absorbed by the ozone layer of the atmosphere.

Identify and name the part of the electromagnetic spectrum to which these radiations belong. Arrange

these wavelengths in decreasing order of magnitude.

Long Questions:

1. Answer the following:

- (a) Name the em waves which are used for the treatment of certain forms of cancer. Write their frequency
- (b) Thin ozone layer on top of the stratosphere is crucial for human survival. Why?
- (c) An em wave exerts pressure on the surface on which it is incident. Justify. (CBSE Delhi 2014)

2. Answer the following questions:

- (a) Why is the thin ozone layer at the top of the stratosphere crucial for human survival? Identify to which part of the electromagnetic spectrum does this radiation belong and write one important application of the radiation.
- (b) Why are infrared waves referred to as heat rays? How are they produced? What role do they play in maintaining the earth's warmth through the greenhouse effect? (CBSE Delhi 2015C)

Assertion and Reason Questions-

1. Two statements are given-one labelled Assertion (A) and the other labelled Reason (R). Select the correct answer to these questions from the codes (a), (b), (c) and (d) as given below.

- a) Both A and R are true and R is the correct explanation of A.
- b) Both A and R are true but R is not the correct explanation of A.
- c) A is true but R is false.
- d) A is false and R is also false.

Assertion: Electromagnetic waves exert pressure called radiation pressure.

Reason: Electromagnetic waves carries energy.

2. Two statements are given-one labelled Assertion (A) and the other labelled Reason (R). Select the correct answer to these questions from the codes (a), (b), (c) and (d) as given below.

- a) Both A and R are true and R is the correct explanation of A.
- b) Both A and R are true but R is not the correct explanation of A.
- c) A is true but R is false.
- d) A is false and R is also false.

Assertion: When a charged particle moves in a circular path. It produces electromagnetic wave.

Reason: Charged particle has acceleration.

Case study Questions-

1. Radio waves are produced by the accelerated motion of charges in conducting wires. Microwaves are produced by special vacuum tubes. Infrared waves are produced by hot bodies and molecules also known as heat waves. UV rays are produced by special lamps and very hot bodies like Sun.

(i) Solar radiation is:

- a) Transverse electromagnetic wave.
- b) Longitudinal electromagnetic waves.
- c) Both longitudinal and transverse electromagnetic waves.
- d) None of these.

(ii) What is the cause of greenhouse effect?

- a) Infrared rays.
- b) Ultraviolet rays
- c) X-rays.

- d) Radiowaves.
- (iii) Biological importance of ozone layer is:
 - a) It stops ultraviolet rays.
 - b) It layer reduces greenhouse effect.
 - c) It reflects radiowaves.
 - d) None of these.
- (iv) Ozone is found in.
 - a) Stratosphere.
 - b) Ionosphere.
 - c) Mesosphere.
 - d) Troposphere.
- (v) Earth's atmosphere is richest in.
 - a) Ultraviolet.
 - b) Infrared.
 - c) X-rays.
 - d) Microwave.

2. Electrons oscillating in a circuit give rise to radiowaves. A transmitting antenna radiates most effectively the radiowaves of wavelength equal to the size of the antenna. The infrared waves incident on a substance set into oscillation all its electrons, atoms and molecules. This increases the internal energy and hence the temperature of the substance.

- (i) If v_g , v_x and v_m are the speeds of gamma rays, X-rays and microwaves respectively in vacuum, the
 - a) $v_g > v_x > v_m$
 - b) $v_g < v_x < v_m$
 - c) $v_g > v_x > v_m$
 - d) $v_g = v_x = v_m$
- (ii) Which of the following will deflect in electric field?
 - a) X-rays.
 - b) γ -rays.
 - c) Cathode rays.
 - d) Ultraviolet rays.

- (iii) γ -rays are detected by:
- Point contact diodes.
 - Thennopiles.
 - Ionization chamber.
 - Photocells.
- (iv) The frequency of electromagnetic wave, which best suited to observe a particle of radius 3×10^{-4} cm is the order of,
- 10^{15} Hz
 - 10^{14} Hz
 - 10^{13} Hz
 - 10^{12} Hz
- (v) We consider the radiation emitted by the human body. Which one of the following statements is true?
- The radiation emitted is in the infrared region.
 - The radiation is emitted only during the day.
 - The radiation is emitted during the summers and absorbed during the winters.
 - The radiation emitted lies in the ultraviolet region and hence it is not visible.

Answer Key:

Multiple Choice Answers-

- Answer: b
- Answer: c
- Answer: b
- Answer: d
- Answer: c
- Answer: a
- Answer: d
- Answer: a
- Answer: b
- Answer: a

Very Short Answers:

- Answer:
 - In the electromagnetic spectrum, long radio waves have the longest wavelength.
 - Radio waves are used in communication systems.
- Answer: The ozone layer absorbs the ultraviolet rays, emitted by the sun, which are harmful to the living tissues of human beings.
- Answer: Infrared rays.
- Answer: They are produced by rapid acceleration and decelerations of electrons in aerials.
- Answer: By the transition of inner-shell electrons.
- Answer: By using a magnetron.
- Answer: The electric and magnetic field vectors will be along the x and y directions.
- Answer: The frequency of electromagnetic waves produced by the oscillating charge of frequency ν is also ν .
- Answer: The three are mutually perpendicular to one other.
- Answer: UV radiations, 10^{15} to 10^{17} Hz.

Short Questions Answers:

- Answer: The radio waves have an atomic origin, while gamma rays have a nuclear origin. Further owing to their very small wavelength, gamma rays are highly penetrating in comparison to radio waves.
- Answer: The average density of the electric field is given by

$$U_E = \frac{1}{2}\epsilon_0 E^2 \text{ and the average energy density of the magnetic field is given by } U_B = \frac{B^2}{2\mu_0}.$$

$$\text{But } B = \frac{E}{c} \text{ and } c = \frac{1}{\sqrt{\mu_0\epsilon_0}}, \text{ hence the above equation becomes } U_B = \frac{B^2}{2\mu_0} = \frac{E^2}{2\mu_0 c^2}$$

$$U_B = \frac{E^2}{2\mu_0 \times \frac{1}{\mu_0\epsilon_0}} = \frac{1}{2}\epsilon_0 E^2. \text{ Hence the result.}$$

- Answer:
 - They do not require any material medium to travel.

(b) They are transverse in nature, i.e. electric and magnetic fields are perpendicular to each other and also to the direction of the propagation of the wave.

(c) The energy of the wave is divided equally amongst the electric and the magnetic field.

(d) They travel, in free space, with a velocity of $3 \times 10^8 \text{ m s}^{-1}$.

4. Answer:

(a) λ_1 – Ultraviolet radiations.

(b) λ_2 – Microwaves

(c) λ_3 – Infrared rays

Their order is $\lambda_1 < \lambda_3 < \lambda_2$.

5. Answer:

(a) Microwaves.

(b) X-rays

(c) Gamma rays

(d) UV rays

(e) Infrared rays

(f) Visible light.

6. Answer:

(a) Infrared rays

(b) Microwaves.

(c) Gamma rays.

7. Answer: Microwaves are electromagnetic waves of very short wavelength. Such waves are used in RADAR due to the reason that they can travel in a particular direction in the form of a beam without being deflected.

8. Answer:

(a) Infrared radiations are used to treat muscular strain.

(b) Radio and microwave radiations are used for FM transmission.

(c) X-rays are used to detect fractures in bones.

(d) Ultraviolet radiation is absorbed by the ozone layer of the atmosphere.

The decreasing order of their wavelength is

$\lambda_2 > \lambda_1 > \lambda_4 > \lambda_3$.

Long Questions Answers:

1. Answer:

(a) Gamma rays.

Frequency range $> 3 \times 10^{20}$ Hz

(b) The thin ozone layer on top of the stratosphere is crucial for human survival because it absorbs most of the ultraviolet rays coming from the sun. If the ozone layer had not been there, then ultraviolet rays would have entered the earth and caused danger to the survival of the human race.

(c) An em wave carries a linear momentum with it. The linear momentum carried by a portion of a wave having energy U is given by $p = U/c$.

Thus, if the wave incident on a material surface is completely absorbed, it delivers energy U and momentum $p = U/c$ to the surface. If the wave is totally reflected, the momentum delivered is $p = 2U/c$ because the momentum of the wave changes from p to $-p$. Therefore, it follows that an em wave incident on a surface exerts a force and hence a pressure on the surface.

2. Answer:

(a) The thin ozone layer on top of the stratosphere is crucial for human survival because it absorbs most of the ultraviolet rays coming from the sun. If the ozone layer had not been there, then ultraviolet rays would have entered the earth and caused danger to the survival of the human race. This radiation is UV radiation. It is used in sterilization.

(b) Infrared radiations heat up the material on which they fall, hence they are also called heat rays. They are produced by the vibration of atoms and molecules. After falling on the earth, they are reflected back into the earth's atmosphere. The earth's atmosphere does not allow these radiations to pass through as such they heat up the earth's atmosphere.

Assertion and Reason Answers-

1. (b) Both A and R are true but R is not the correct explanation of A.

Explanation:

Electromagnetic waves transport linear momentum as well as energy. When electromagnetic waves strike a surface, a pressure is exerted on the surface. If the intensity of wave is I , the radiation pressure P (force per unit area) exerted on the

perfectly absorbing surface is $p = \frac{I}{c}$.

2. (a) Both A and R are true and R is the correct explanation of A.

Explanation:

Accelerated charges radiate electromagnetic waves.

Case Study Answers-

1. Answer :

(i) (a) Transverse electromagnetic wave.

(ii) (a) Infrared rays.

Explanation:

Greenhouse effect is due to infrared rays.

(iii) (a) It stops ultraviolet rays.

Explanation:

Ozone layer absorbs the harmful ultraviolet radiations coming from the sun.

(iv) (a) Stratosphere.

Explanation:

Ozone layer lies in stratosphere.

(v) (b) Infrared.

Explanation:

Heatmosphere of earth is richest in infrared radiation.

2. Answer :

(i) (d) $v_g = v_x = v_m$

Explanation:

All electromagnetic waves travel in vacuum with the same speed.

(ii) (c) Cathode rays.

Explanation:

Cathode rays (beam of electrons) get deflected in an electric field.

(iii) (c) Ionization chamber.

Explanation:

γ -rays are detected by ionization chamber.

(iv) (b) 10^{14}Hz

Explanation:

$$\text{Size of particle} = \lambda = \frac{c}{\nu}$$

$$\nu = \frac{c}{\lambda} = \frac{3 \times 10^{10} \text{cm s}^{-1}}{3 \times 10^{-4} \text{cm}} = 3 \times 10^{14} \text{Hz}$$

(v) (a) The radiation emitted is in the infrared region.

Explanation:

Every body at a temperature $T > 0$ K emits radiation in the infrared region.



C V RAMAN
P U C O L L E G E
I N D I

CHAPTER 9: RAY OPTICS AND OPTICAL INSTRUMENTS

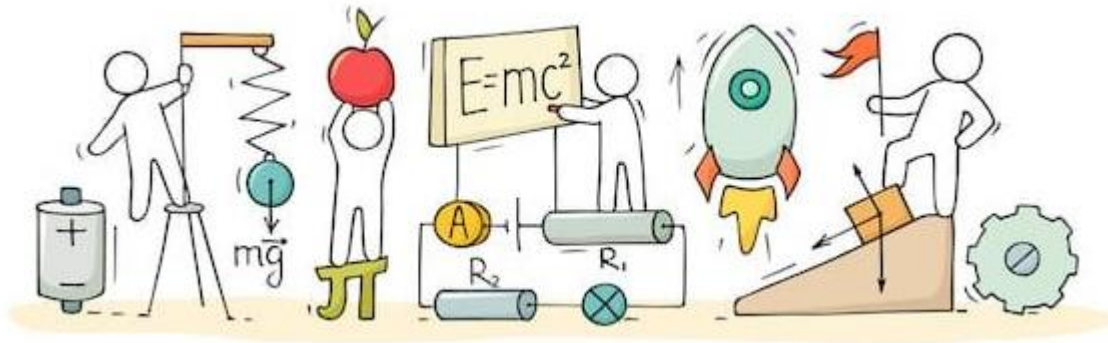

RAY OPTICS AND OPTICAL INSTRUMENTS

Ray Optics or Geometrical Optics:

In this optics, the light is considered as a ray which travels in a straight line. It states that for each and every object, there is an image.

Reflection of Light:

The phenomenon in which a light ray is sent back into the same medium from which it is coming, on interaction with a boundary, is called reflection. The boundary can be a rigid surface or just an interface between two media.

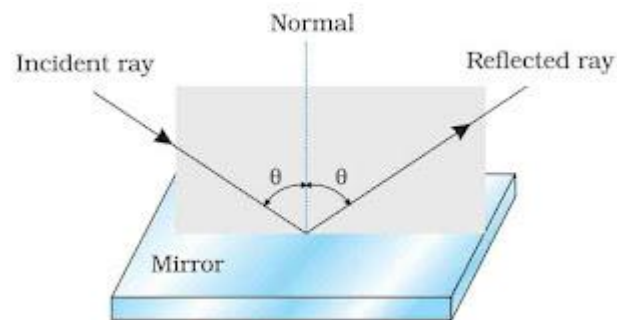

Law of reflection:

The angle of reflection equals the angle of incidence $\angle i = \angle r$.

The incident ray reflected ray and the normal to the reflecting surface at the point of incidence lie in the same plane.

Formation of Image by the Plane Mirror:

The formation of image of a point object O by a plane mirror is represented in figure.

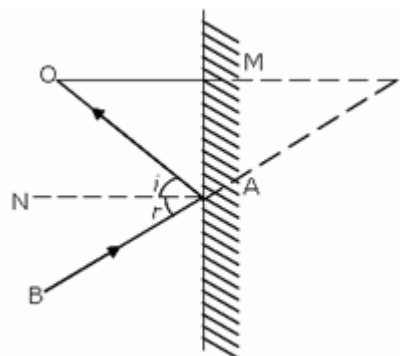

The image formed I has the following characteristics:

- The size of image is equal to the size of object.
- The object distance = Image distance i.e., $OM = MI$.
- The image is virtual and erect.
- When a mirror is rotated through a certain angle, the reflected ray is rotated through twice this angle.

Spherical Mirrors:

A spherical mirror is a part of sphere. If one of the surfaces is silvered, the other surface acts as the reflecting surface. When convex face is silvered, and the reflecting surface is concave, the mirror is called a concave mirror. When its concave face is silvered and convex face is the reflecting face, the mirror is called a convex mirror.

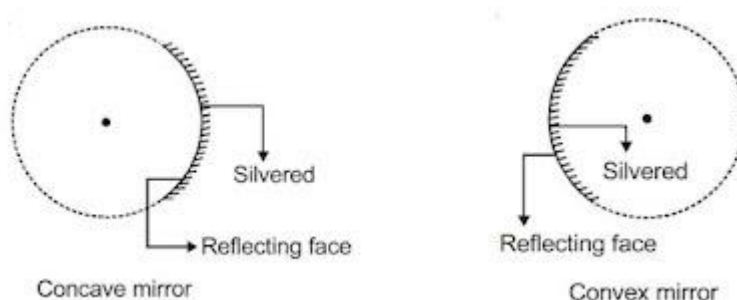

- **Centre of curvature:** Centre of curvature is the center of sphere of which, the mirror is a part.
- **Radius of curvature:** Radius of curvature is the radius of sphere of which, the mirror is a part.
- **Pole of mirror:** Pole is the geometric center of the mirror.
- **Principal axis:** Principal axis is the line passing through the pole and center of curvature.
- **Normal:** Any line joining the mirror to its center of curvature is normal.

Reflection of Light from Spherical Mirror:

1. A spherical mirror is a part cut from a hollow sphere.
2. They are generally constructed from glass.
3. The reflection at spherical mirror also takes place in accordance with the laws of reflection.

Refraction of light:

Refraction is the bending of a wave when it passes from one medium to another. The bending is caused due to the differences in density between the two substances.

“Refraction is the change in the direction of a wave passing from one medium to another.”

Laws of Refraction:

Two laws of refraction are given as below:

- The incident ray, refracted ray and the normal to the refracting surface at the point of incidence lie in the same plane.
- The ratio of the sine of the angle of incidence to the sine of the angle of refraction is constant for the two-given media. This constant is denoted by n and is called the relative refractive index.

$$n = \frac{\sin i}{\sin r} \text{ (Snell's law)}$$

where, n is refractive index of the second medium when first medium is air.

Sign Convention:

Following sign conventions are the new cartesian sign convention:

- All distances are measured from the pole of the mirror & the distances measured in the direction of the incident light is taken as positive. In other words, the distances measured toward the right of the origin are positive.
- The distance measured against the direction of the incident light are taken as negative. In other words, the distances measured towards the left of origin are taken as negative.
- The distance measured in the upward direction, perpendicular to the principal axis of the mirror, are taken as positive & the distances measured in the downward direction are taken as negative.

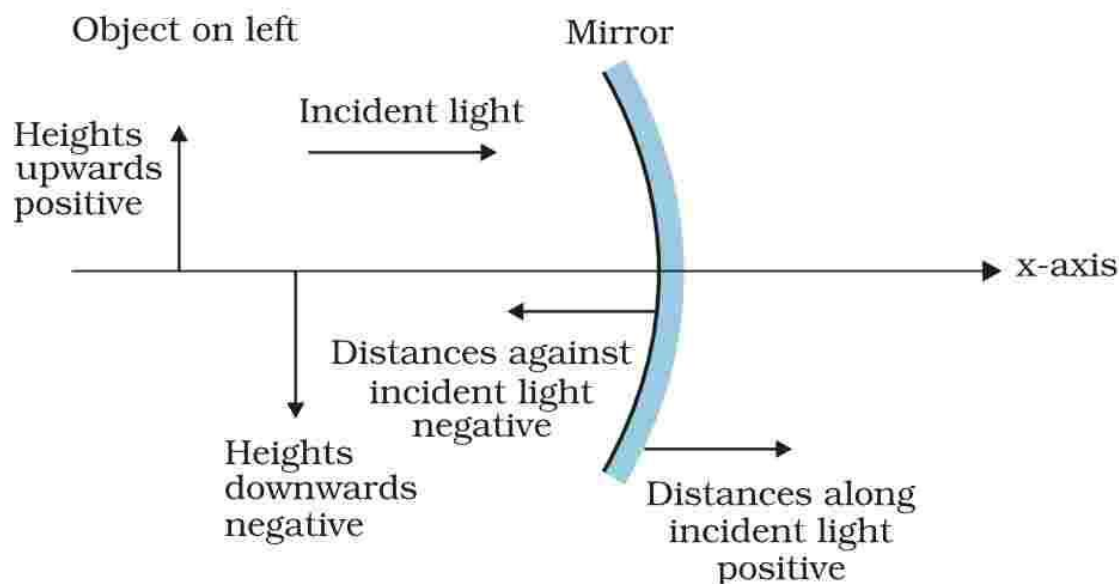

Focal Length of Spherical Mirrors:

When a parallel beam of light is incident on a concave mirror, and a convex mirror. The rays are incident at points close to the pole P of the mirror and make small angles with the principal axis. The reflected rays converge at a point F on the principal axis of a concave mirror. For a convex mirror, the reflected rays appear to diverge from a point F on its principal axis.

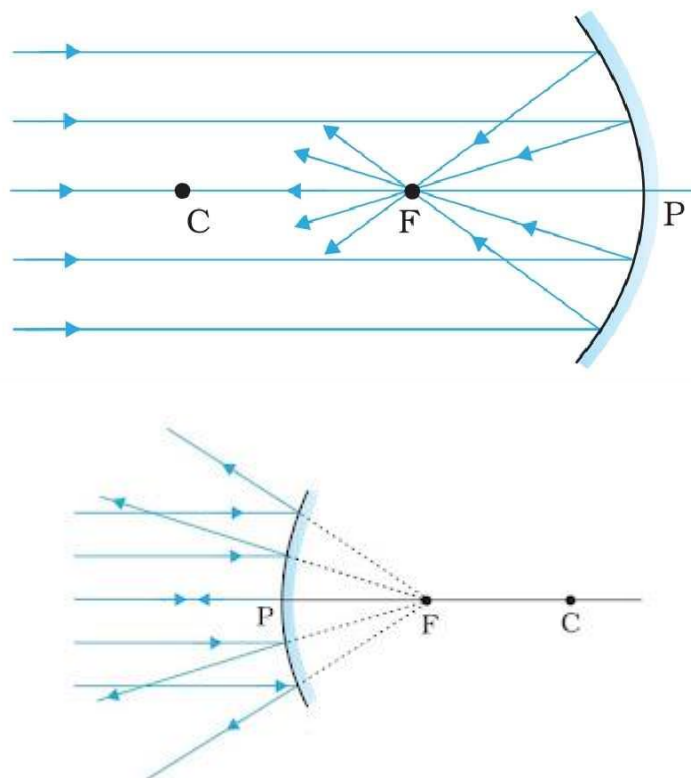

The point F is called the principal focus of the mirror. The distance between the focus F

and the pole P of the mirror is called the focal length of the mirror, denoted by f .

If, R be the radius of curvature of the mirror then relation between R and f is given by

$$f = \frac{R}{2}$$

Principal Axis of the Mirror:

The straight line joining the pole and the centre of curvature of spherical mirror extended on both sides is called principal axis of the mirror.

Mirror Formula:

$$\frac{1}{f} = \frac{1}{u} + \frac{1}{v}$$

Where u = distance of the object from the pole of mirror

v = distance of the image from the pole of mirror

f = focal length of the mirror

$f = \frac{R}{2}$ Where R is the radius of curvature of the mirror.

Lens:

Lens is a transparent medium bounded by two surfaces of which one or both surfaces are spherical.

Lens Formula:

Lens formula relates the distance of object from the lens with distance of image from the lens. It is given by.

$$\frac{1}{f} = \frac{1}{v} - \frac{1}{u}$$

Where, u = object distance

v = image distance

f = focal length

Lens Maker's Formula:

Lens Maker's formula gives the focal length of a lens in terms of the nature of the surfaces by which the lens is bounded and the nature of material of the lens.

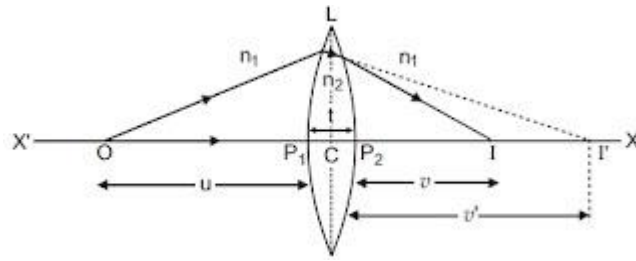

Let us consider the situation shown in figure. C_1 and C_2 are the centers of curvature of two spherical surfaces of the thin lens. O is the object and I' is the image due to first refraction. Let radii of curvature be R_1 and R_2 .

For the first refraction at image distance is v_1 . From the formula for refraction at a curved surface, we get

$$\frac{n_2}{v_1} = \frac{n_1}{u} = \frac{n_2 - n_1}{R_1} \dots (i)$$

Final image position is I , which is also the image due to second refraction. Let this image distance be v . For the second refraction, v_1 becomes the object distance. Hence we get,

$$\frac{n_1}{v} = \frac{n_2}{v_1} = \frac{n_1 - n_2}{R_2} \dots (ii)$$

Adding (i) and (ii), we get

$$\left(\frac{n_1}{v} - \frac{n_1}{u}\right) = (n_2 - n_1) \left(\frac{1}{R_1} - \frac{1}{R_2}\right)$$

$$\frac{1}{v} - \frac{1}{u} = \left(\frac{n_2}{n_1} - 1\right) \left(\frac{1}{R_1} - \frac{1}{R_2}\right)$$

$$\frac{1}{v} - \frac{1}{u} = (n - 1) \left(\frac{1}{R_1} - \frac{1}{R_2}\right)$$

According to the definition of the focal length f

$$\frac{1}{f} = (n - 1) \left(\frac{1}{R_1} - \frac{1}{R_2}\right)$$

This is called the "Lens Maker's formula".

Power of Lens:

The ability of a lens to converge or diverge the rays of light incident on it is called the power of the lens.

$$P = \frac{1}{f(\text{in m})}$$

SI unit of power lens = dioptre (D) = m^{-1}

Prism:

prism, in optics, piece of glass or other transparent material cut with precise angles and plane faces, useful for analyzing and reflecting light. An ordinary triangular prism can separate white light into its constituent colors, called a spectrum. Each color, or wavelength, making up the white light is bent, or refracted, a different amount; the shorter wavelengths (those toward the violet end of the spectrum) are bent the most, and the longer wavelengths (those toward the red end of the spectrum) are bent the least. Prisms of this kind are used in certain spectrosopes, instruments for analyzing light and for determining the identity and structure of materials that emit or absorb light.

Dispersion: When white light is incident on a prism, different colors having different wavelengths suffer different deviations. The phenomenon of splitting of light into its component colors is known as dispersion. The pattern of color components of light (VIBGYOR) is called the spectrum of light. The deviation produced by a thin prism depends on the refractive index.

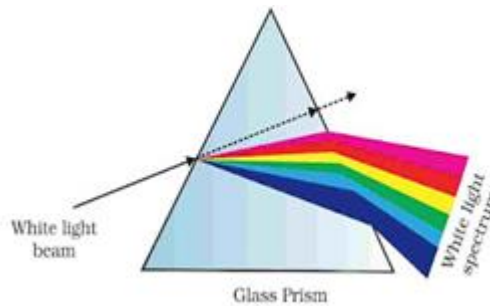

Angular Dispersion: Angular dispersion produced by a prism for white light is the difference in the angles of deviation for two extreme colors i.e., violet and red. It is given by.

$$\theta = \delta_V - \delta_R$$

$$\theta = (n_V - n_R)A$$

Dispersive Power: Dispersive power of a prism is defined as the ratio of angular dispersion to the mean deviation produced by the prism.

$$\omega = \frac{\delta_V - \delta_R}{\delta_Y}$$

Optical Instruments:

Optical instruments are the devices which help human eye in observing highly magnified images of tiny objects, for detailed examination and in observing very far objects whether terrestrial or astronomical.

The Eye: Light enters the eye through cornea a curved front surface. It passes through the pupil which is the central hole in the iris. The size of pupil can change under control of muscles. The light is further focused by the eye lens on the retina. The retina is a film of nerve fibers covering the curved black surface of the eye. The retina contains rods and cones which sense light intensity and color respectively and transmit electrical signals via the optic nerve to the brain.

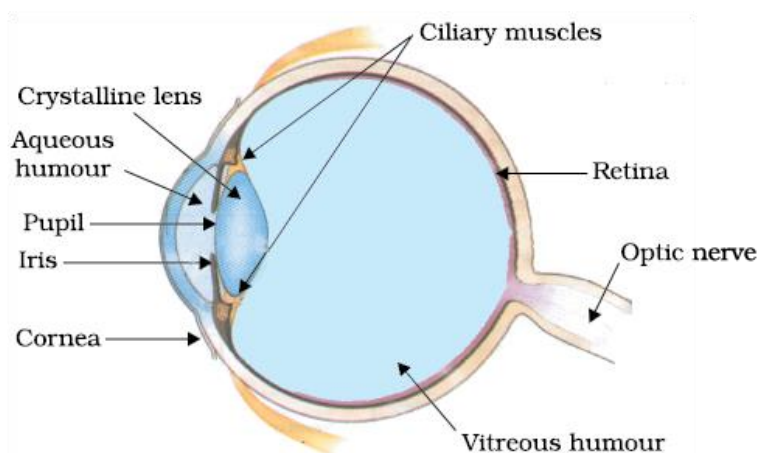

The shape (curvature) and therefore the focal length of the lens can be modified somewhat by ciliary muscles. So, images are formed at the retina for objects at all distances. This property of the eye is called accommodation.

The closest distance for which the eye lens can focus light on the retina is called the least distance of distinct vision or the near point. The standard value for normal vision is taken as 25cm (Symbol D). If the object is too close to eye; the lens cannot curve enough to focus the image on the retina, and the image is blurred.

The microscope: A simple magnifier or microscope is a converging lens of small focal length. The lens nearest the object, called the objective, forms a real, inverted, magnified image of the object. This serves as the object for the second lens, the eyepiece, which functions essentially like a simple microscope or magnifier, producing an enlarged virtual final image.

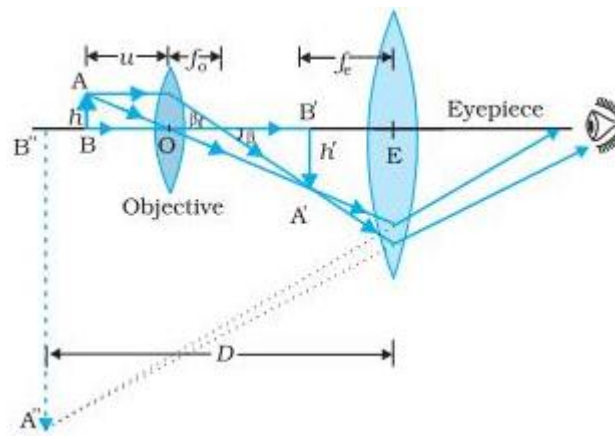

The first inverted image is thus near (at or within) the focal point of the eyepiece, at a distance appropriate for final image formation at infinity, or a little closer for image formation at the near point. Clearly, the final image is inverted with respect to the original object.

Magnification power is given by

$$m = \frac{v_0}{u_0} \left[\frac{D}{v} + \frac{D}{f_e} \right]$$

Telescope: This device is used to observe objects which are far away. However, a telescope has an objective lens of large aperture and considerable focal length and eye lens that with a small aperture and focal length.

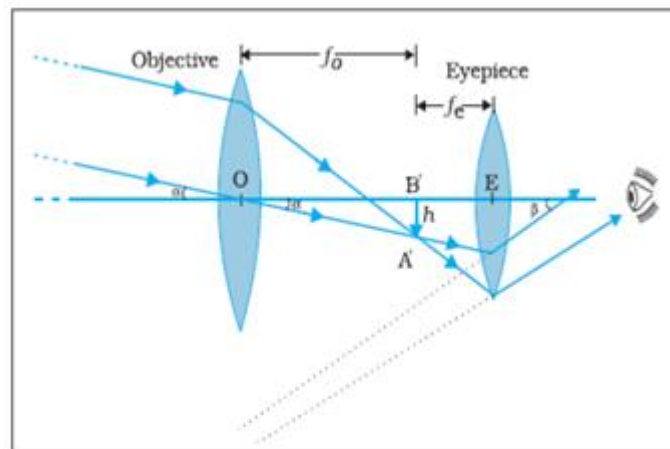

Magnifying power is given by

$$m = -f_0 \left[\frac{1}{f_e} + \frac{1}{v} \right]$$

Reflecting Telescope (Cassegrain telescope):

In such telescope, one objective lens is replaced by a concave parabolic mirror of large aperture, which is free from chromatic and spherical aberrations.

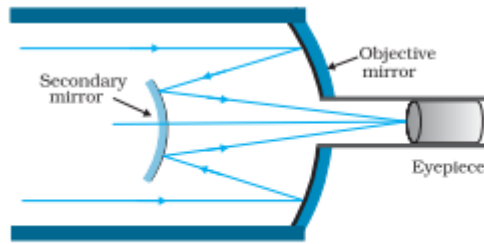

Schematic diagram of a reflecting telescope (Cassegrain).

In normal adjustment, magnifying power

$$m = \frac{f_0}{f_e} = \frac{R}{2f_e}$$

Advantages of taking mirror objectives are:

- There is no chromatic aberration in a mirrors.
- If a parabolic reflecting surface is chosen, spherical aberration is also removed.
- Mechanical support is much less of a problem since a mirror weighs much less than a lens of equivalent optical quality and can be supported over.
- Entire back surface not just over rim unlike lens.

Class : 12th Physics
Chapter- 9 : Ray Optics and Optical Instruments

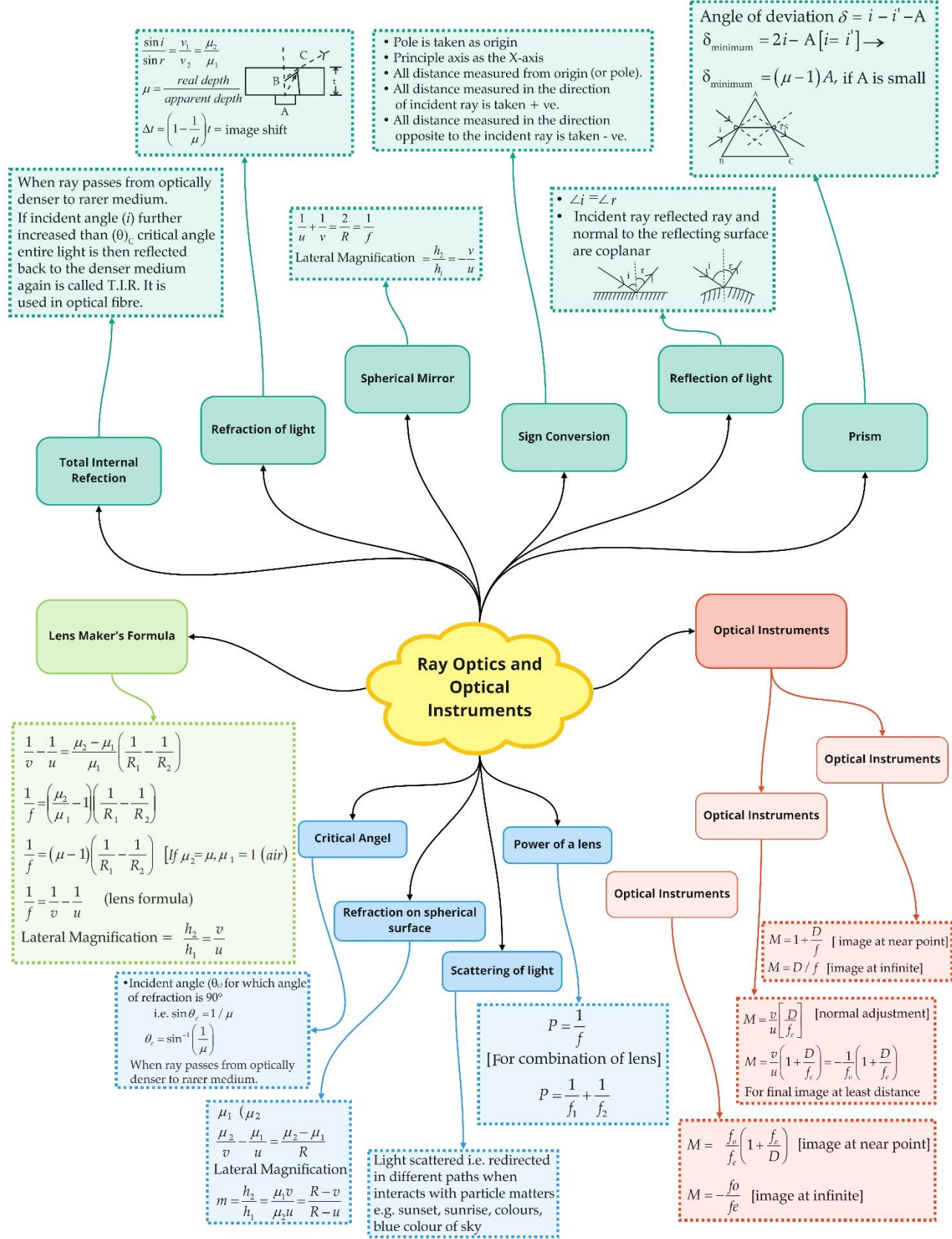

Important Questions

Multiple Choice questions-

- For a total internal reflection, which of the following is correct?
 - Light travels from rarer to denser medium.
 - Light travels from denser to rarer medium.
 - Light travels in air only.
 - Light travels in water only.
- Critical angle of glass is θ_1 and that of water is θ_2 . The critical angle for water and glass surface would be ($\mu_g = 3/2$, $\mu_w = 4/3$).
 - less than θ_2
 - between θ_1 and θ_2
 - greater than θ_2
 - less than θ_1
- Mirage is a phenomenon due to
 - refraction of light
 - reflection of light
 - total internal reflection of light
 - diffraction of light.
- A convex lens is dipped in a liquid whose refractive index is equal to the refractive index of the lens. Then its focal length will
 - become zero
 - become infinite
 - become small, but non-zero
 - remain unchanged
- Which of the following forms a virtual and erect image for all positions of the object?
 - Concave lens
 - Concave mirror
 - Convex mirror
 - Both (a) and (c)
- Two lenses of focal lengths 20 cm and -40 cm are held in contact. The image of an object at infinity will be formed by the combination at
 - 10 cm

- (b) 20 cm
- (c) 40 cm
- (d) infinity

7. Two beams of red and violet color are made to pass separately through a prism (angle of the prism is 60°). In the position of minimum deviation, the angle of refraction will be

- (a) 30° for both the colors
- (b) greater for the violet color
- (c) greater for the red color
- (d) equal but not 30° for both the colors

8. Which of the following colours of white light deviated most when passes through a prism?

- (a) Red light
- (b) Violet light
- (c) Yellow light
- (d) Both (a) and (b)

9. An under-water swimmer cannot see very clearly even in absolutely clear water because of

- (a) absorption of light in water
- (b) scattering of light in water
- (c) reduction of speed of light in water
- (d) change in the focal length of eye lens

10. An astronomical refractive telescope has an objective of focal length 20 m and an eyepiece of focal length 2 cm. Then

- (a) the magnification is 1000
- (b) the length of the telescope tube is 20.02 m
- (c) the image formed of inverted
- (d) all of these

Very Short:

1. When light undergoes refraction at the surface of separation of two media, what happens to its frequency/wavelength?
2. Define the refractive index.
3. What is the distance between the objective and eyepiece of an astronomical telescope in its normal adjustment?
4. Name the phenomenon responsible for the reddish appearance of the sun at sunrise and sunset.

5. What are the two main considerations that have to be kept in mind while designing the 'objective' of an astronomical telescope?
6. Under what condition does a biconvex lens of glass having a certain refractive index act as a plane glass sheet when immersed in a liquid? (CBSE Delhi 2012)
7. Write the relationship between the angle of incidence 'i', angle of prism 'A' and angle of minimum deviation for a triangular prism. (CBSE Delhi 2013)
8. Why can't we see clearly through the fog? Name the phenomenon responsible for it. (CBSE AI 2016)
9. How does the angle of minimum deviation of a glass prism vary if the incident violet light is replaced by red light? Give reason. (CBSE AI 2017)
10. The objective lenses of two telescopes have the same apertures but their focal lengths are in the ratio 1: 2. Compare the resolving powers of the two telescopes. (CBSE AI 2017C)

Short Questions:

1. The aperture of the objective lens of an astronomical telescope is doubled. How does it affect
 - (i) the resolving power of the telescope and
 - (ii) the intensity of the image? (CBSE Sample Paper 2018-19)
2. How does the resolving power of a compound microscope change on (a) decreasing the wavelength of light used, and (b) decreasing the diameter of the objective lens?
3. The layered lens shown in the figure is made of two kinds of glass. How many and what kinds of images will be produced by this lens with a point source placed on the optic axis? Neglect the reflection of light at the boundaries between the layers.
4. Monochromatic light is refracted from air into a glass of refractive index n . Find the ratio of wavelengths of the incident and refracted light.
5. Draw a labelled ray diagram to show the image formation in a compound microscope.
6. A ray of light while travelling from a denser to a rarer medium undergoes total internal reflection. Derive the expression for the critical angle in terms of the speed of light in the two media.
7. Draw a labelled diagram for a refracting type astronomical telescope. How will its magnifying power be affected by increasing for its eyepiece (a) the focal length and (b) the aperture? Justify your answer. Write two drawbacks of refracting type telescopes. (CBSE Sample Paper 2018-19)

8. Draw a labelled ray diagram of a Newtonian type reflecting telescope. Write any one advantage over refracting type telescope.

Long Questions:

1. Draw a labelled ray diagram to show the image formation in a refracting type of astronomical telescope. Obtain an expression for the angular magnifying power and the length of the tube of an astronomical telescope in its 'normal adjustment' position. Why should the diameter of the objective of a telescope be large?
2. Draw a ray diagram to show the formation of an erect image of an object kept in front of a concave mirror. Hence deduce the mirror formula. (CBSE 2019C)

Assertion and Reason Questions:

1. Two statements are given-one labelled Assertion (A) and the other labelled Reason (R). Select the correct answer to these questions from the codes (a), (b), (c) and (d) as given below.

- a) Both A and R are true and R is the correct explanation of A.
- b) Both A and R are true but R is not the correct explanation of A.
- c) A is true but R is false.
- d) A is false and R is also false.

Assertion: If optical density of a substance is more than that of water, then the mass density of substance can be less than water.

Reason: Optical density and mass density are not related.

2. Two statements are given-one labelled Assertion (A) and the other labelled Reason (R). Select the correct answer to these questions from the codes (a), (b), (c) and (d) as given below.

- a. Both A and R are true and R is the correct explanation of A.
- b. Both A and R are true but R is not the correct explanation of A.
- c. A is true but R is false.
- d. A is false and R is also false.

Assertion: A single lens produces a coloured image of an object illuminated by white light.

Reason: The refractive index of the material of lens is different for different wavelengths of light.

Case Study Questions:

1. An optical fibre is a thin tube of transparent material that allows light to pass through, without being refracted into the air or another external medium. It makes use of total internal reflection. These fibres are fabricated in such a way that light

reflected at one side of the inner surface strikes the other at an angle larger than critical angle. Even, if fibre is bent, light can easily travel along the length.

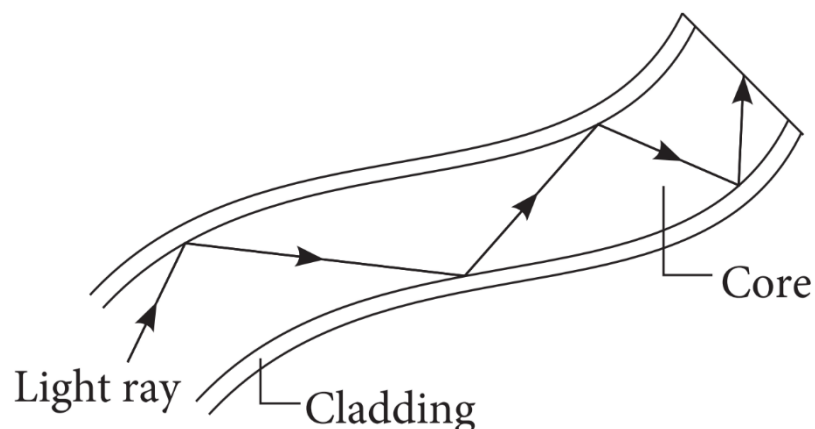

- (i) Which of the following is based on the phenomenon of total internal reflection of light?
- Sparkling of diamond.
 - Optical fibre communication.
 - Instrument used by doctors for endoscopy.
 - All of these.
- (ii) A ray of light will undergo total internal reflection inside the optical fibre, if it.
- Goes from rarer medium to denser medium.
 - Is incident at an angle less than the critical angle.
 - Strikes the interface normally.
 - Is incident at an angle greater than the critical angle.
- (iii) If in core, angle of incidence is equal to critical angle, then angle of refraction will be.
- 0°
 - 45°
 - 90°
 - 180°
- (iv) In an optical fibre (shown), correct relation for refractive indices of core and cladding is:

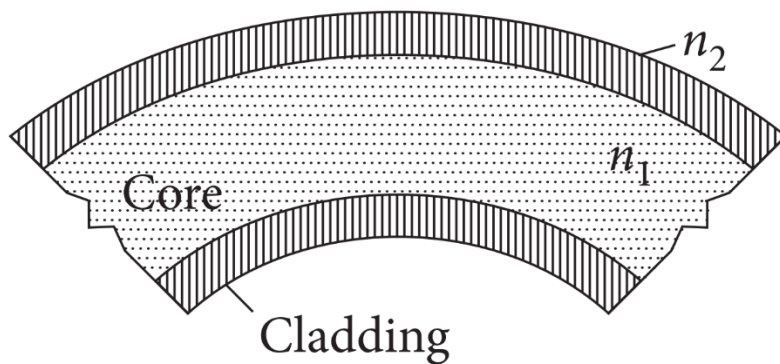

- a. $n_1 = n_2$
- b. $n_1 > n_2$
- c. $n_1 < n_2$
- d. $n_1 + n_2 = 2$

(v) If the value of critical angle is 30° for total internal reflection from given optical fibre, then speed of light in that fibre is:

- a. $3 \times 10^8 \text{ms}^{-1}$
- b. $1.5 \times 10^8 \text{ms}^{-1}$
- c. $6 \times 10^8 \text{ms}^{-1}$
- d. $4.5 \times 10^8 \text{ms}^{-1}$

2. An astronomical telescope is an optical instrument which is used for observing distinct images of heavenly bodies like stars, planets etc. It consists of two lenses. In normal adjustment of telescope, the final image is formed at infinity. Magnifying power of an astronomical telescope in normal adjustment is defined as the ratio of the angle subtended at the eye by the angle subtended at the eye by the final image to the angle subtended at the eye, by the object directly, when the final image and the object both lie at infinite distance from the eye. It is given by, $m = \frac{f_o}{f_g}$. To increase magnifying power of an astronomical telescope in normal adjustment, focal length of objective lens should be large and focal length of eye lens should be small.

- (i) An astronomical telescope of magnifying power 7 consists of the two thin lenses 40cm apart, in normal adjustment. The focal lengths of the lenses are
 - a) 5cm, 35cm
 - b) 7cm, 35cm
 - c) 17cm, 35cm
 - d) 5cm, 30cm
- (ii) An astronomical telescope has a magnifying power of 10. In normal adjustment, distance between the objective and eye piece is 22cm. The focal length of objective lens is:
 - a) 25cm

- b) 10cm
 - c) 15cm
 - d) 20cm
- (iii) In astronomical telescope compare to eye piece, objective lens has:
- a) Negative focal length.
 - b) Zero focal length.
 - c) Small focal length.
 - d) Large focal length.
- (iv) To see stars, use:
- a) Simple microscope.
 - b) Compound microscope.
 - c) Endoscope.
 - d) Astronomical telescope.
- (v) For large magnifying power of astronomical telescope.
- a) $f_0 \ll f_e$
 - b) $f_0 \ll f_e$
 - c) $f_0 \ll f_e$
 - d) None of these.

✓ Answer Key:

Multiple Choice Answers-

1. Answer: b
2. Answer: c
3. Answer: c
4. Answer: b
5. Answer: d
6. Answer: c
7. Answer: a
8. Answer: b
9. Answer: d

10. Answer: d

Very Short Answers:

1. Answer: There is no change in its frequency, but its wavelength changes.
2. Answer: The Refractive index of a medium is defined as the ratio of the speed of light in a vacuum to the speed of light in the given medium.
3. Answer: Distance between objective and eyepiece of telescope = $f_o + f_e$
4. Answer: Atmospheric refraction.
5. Answer: Two main considerations are
 - Large light gathering power
 - Higher resolution (or resolving power)
6. Answer: When the refractive index of the liquid is equal to the refractive index of a glass of which the lens is made.
7. Answer: $2i = A + \delta_m$
8. Answer: Because it scatters light. Scattering of light.
9. Answer: It decreases as $\delta_m \propto \frac{1}{\lambda}$
10. Answer: Same as resolving power does not depend upon the focal length of lenses.

Short Questions Answers:

1. Answer:

The resolving power of a telescope is given by the expression $\frac{D}{1.22\lambda}$.

(i) When the aperture of the objective lens is increased, the resolving power of the telescope increases in the same ratio.

(ii) The intensity of the image is given by the expression $\beta \propto D^2$, thus when the aperture is doubled, the intensity of the image becomes four times.

2. Answer:

The resolving power of a microscope is given by the expression $RP = \frac{2n\sin\theta}{\lambda}$

(a) If the wavelength of the incident light is decreased, the resolving power of the microscope increases.

(b) There is no effect of the decrease in the diameter of the objective on the resolving power of the microscope.

3. Answer: Two images will be formed as the lens may be thought of, as two separate lenses of different focal lengths. The images will be surrounded by bright halos.

4. Answer: Using the relation $\lambda_1 n_1 = \lambda_2 n_2$ we have

$$\frac{\lambda_1}{\lambda_2} = n$$

5. Answer: The labelled diagram is as shown.

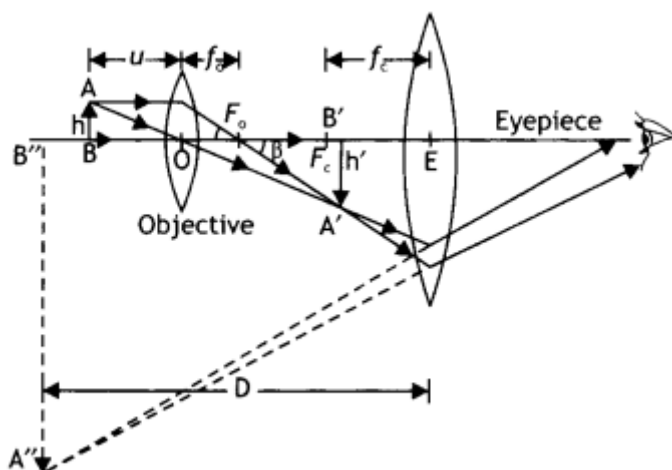

6. Answer:

Snell's law can be used to find the critical angle. Now Snell's law, when the ray moves from denser medium 'b' to rarer medium 'a', is given by

$${}_b n_a = \frac{\sin i_c}{\sin 90^\circ} \quad \dots(1)$$

$$\text{But } {}_a n_b = \frac{1}{{}_b n_a}$$

Therefore, the above equation can be

$$\text{written as } \frac{1}{{}_a n_b} = \frac{\sin i_c}{\sin 90^\circ} \quad \dots(2)$$

$${}_a n_b = \frac{1}{\sin i_c} \quad \dots(3)$$

Now we know that $n = \frac{c}{v}$, substituting in the above relation we have

$$\frac{c}{v} = \frac{1}{\sin i_c} \text{ or } \sin i_c = \frac{v}{c}$$

7. Answer: The labelled diagram of the telescope is as shown in the figure.

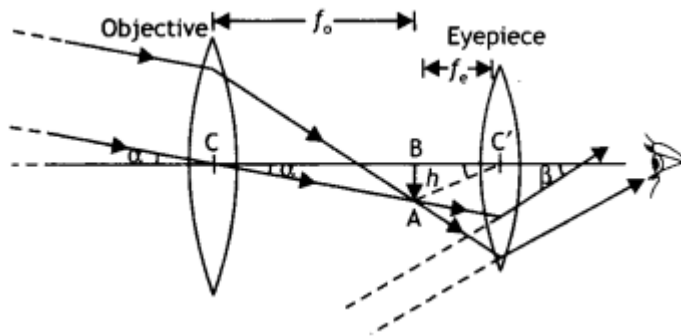

(a) The magnifying power of a telescope is given by $M = \frac{f_o}{f_e}$. If the focal length of the eyepiece is increased, it will decrease the magnifying power of the telescope.

(b) Magnifying power does not depend upon the aperture of the eyepiece. Therefore, there is no change in the magnifying power if the aperture of the eyepiece is increased.

Drawbacks:

- Large-sized lenses are heavy and difficult to support.
- Large-sized lenses suffer from chromatic and spherical aberration.

8. Answer: The labelled diagram is shown below.

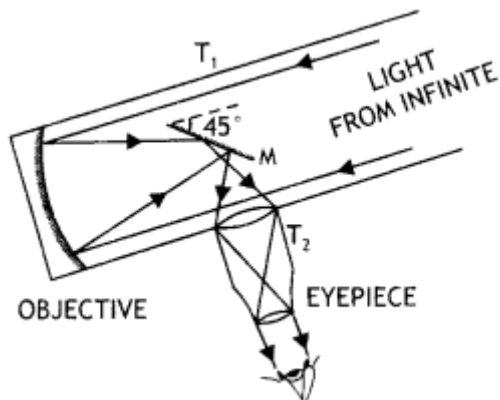

Due to the large aperture of the mirror as compared to a lens the image formed is much brighter than that formed by a refracting type of telescope.

Long Questions Answers:

1. Answer:

A labelled diagram of the telescope is shown in the figure.

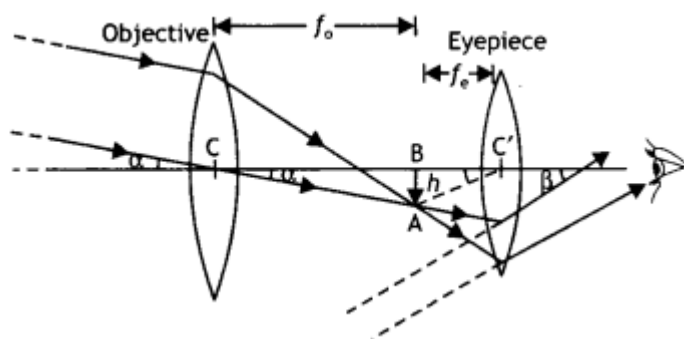

The object subtends an angle at the objective and would subtend essentially the same angle at the unaided eye. Also, since the observers' eye is placed just to the right of the focal point f'_2 , the angle subtended at the eye by the final image is very nearly equal to the angle β .

Therefore, $M = \frac{\beta}{\alpha} = \frac{\tan \beta}{\tan \alpha} \dots(1)$

From right triangles ABC and $A'B'C'$ as shown in figure, we have

$\tan \alpha = \frac{AB}{CB} = \frac{-h}{f_o}$ and

$\tan \beta = \frac{A'B'}{C'A} = \frac{-h'}{f_e}$

substituting the above two equations in equation (1), we have

$M = \frac{\beta}{\alpha} = \frac{-h'}{f_e} \times \frac{f_o}{-h} = \frac{f_o}{f_e}$

The length of the telescope is the distance between the two lenses which is $L = f_o + f_e$. The diameter of the objective of a telescope should be large so that it can collect more light and image of distant objects is formed clear.

2. Answer:

An object AB is placed between P and F . The course of rays for obtaining erect image A_1B_1 of object AB is shown in the figure.

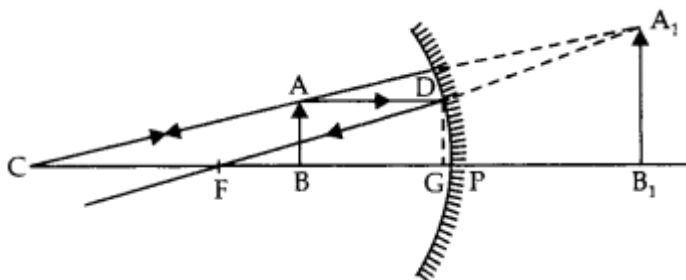

Draw $DG \perp$ on the principal axis.

Triangles DGF and A_1B_1C are similar

$$\therefore \frac{DG}{A_1B_1} = \frac{GF}{FB_1}$$

$$\text{or } \frac{AB}{A_1B_1} = \frac{GF}{FB_1} \quad [\because DG = AB] \quad \dots(i)$$

Again triangles ABC and A_1B_1C are similar

$$\therefore \frac{AB}{A_1B_1} = \frac{CB}{CB_1} \quad \dots(ii)$$

From Eqs. (i) and (ii), we have

$$\frac{GF}{FB_1} = \frac{CB}{CB_1}$$

Since Point G is close to P, so $GF = PF$

$$\therefore \frac{PF}{FB_1} = \frac{CB}{CB_1}$$

Using sign conventions, we get

$$\frac{PF}{PF + PB_1} = \frac{PC - PB}{PC + PB_1}$$

$$\text{or } \frac{-f}{-f + v} = \frac{-2f + u}{-2f + v}$$

Multiplying and dividing both sides by uvf , we get

$$\frac{1}{f} = \frac{1}{v} + \frac{1}{u}$$

Assertion and Reason Answers:

1. (a) Both A and R are true and R is the correct explanation of A.

Explanation:

Optical density and mass density are not related to each other. Mass density is mass per unit volume. It is possible that mass density of an optically denser medium be less than that of an optically rarer medium (optical density is the ratio of the speed of light in two media). e.g., turpentine and water. Mass density of turpentine is less than that of water but its optical density is higher.

2. (a) Both A and R are true and R is the correct explanation of A.

Explanation:

Due to the variation of the refractive index of the material of the lens, the focal length also varies accordingly. Now as white light is composed of different colours of light, each colour will produce its own image based on the focal length for that colour. This particular phenomenon for a single lens is known as chromatic aberration.

Case Study Answers:

1. Answer :

(i) (d) All of these.

Explanation:

Total internal reflection is the basis for following phenomenon:

- Sparkling of diamond.
- Optical fibre communication.
- Instrument used by doctors for endoscopy.

(ii) (d) Is incident at an angle greater than the critical angle.

Explanation:

Total internal reflection (TIR) is the phenomenon that involves the reflection of all the incident light off the boundary. TIR only takes place when both of the following two conditions are met: The light is in the more denser medium and approaching the less denser medium.

The angle of incidence is greater than the critical angle.

(iii) (c) 90°

Explanation:

If incidence of angle, $i =$ critical angle C , then angle of refraction, $r = 90^\circ$

(iv)(b) $n_1 > n_2$

Explanation:

In optical fibres, core is surrounded by cladding, where the refractive index of the material of the core is higher than that of cladding to bound the light rays inside the core.

(v) (b) $1.5 \times 10^8 \text{ms}^{-1}$

Explanation:

From Snell's law, $\sin C = {}_1n_2 = \frac{v_1}{v_2}$

Where, $C =$ critical angle $= 30^\circ$ and v_1 and v_2 are speed of light in medium and vacuum, respectively. We know that, $v_2 = 3 \times 10^8 \text{ms}^{-1}$

$$\therefore \sin 30^\circ = \frac{v_1}{3 \times 10^8}$$

$$\Rightarrow v_1 = 3 \times 10^8 \times \frac{1}{2}$$

$$\Rightarrow v_1 = 1.5 \times 10^8 \text{ms}^{-1}$$

2. Answer :

i. (a) 5cm, 35cm

Explanation:

$$m = \frac{f_0}{f_e} = 7$$

$$f_0 = 7f_e$$

In normal adjustment, distance between the lenses,

$$f_0 + f_e = 40$$

$$7f_0 + f_e = 40 \Rightarrow f_e = \frac{40}{8} = 5\text{cm}$$

$$f_0 = 7f_e = 7 \times 5 = 35\text{cm}$$

ii. (d) 20cm

Explanation:

$$m = -10; L = 22\text{cm}$$

$$\text{As, } m = \frac{-f_0}{f_e} \Rightarrow -10 = -\frac{f_0}{f_e}$$

$$f_0 = 10f_e$$

$$\text{As, } L = f_0 + f_e$$

$$22 = 10f_e + f_e = 11f_e$$

$$\text{or } f_e = \frac{22}{11} = 2\text{cm}$$

$$f_0 = 10f_e = 20\text{cm}$$

iii. (d) Large focal length.

Explanation:

Objective lens has larger focal length than eye-piece.

iv. (d) Astronomical telescope.

Explanation:

Astronomical telescope is used to see stars, sun etc.

v. (c) $f_0 \ll f_e$



C V RAMAN
P U C O L L E G E
INDI

CHAPTER 10: WAVE OPTICS

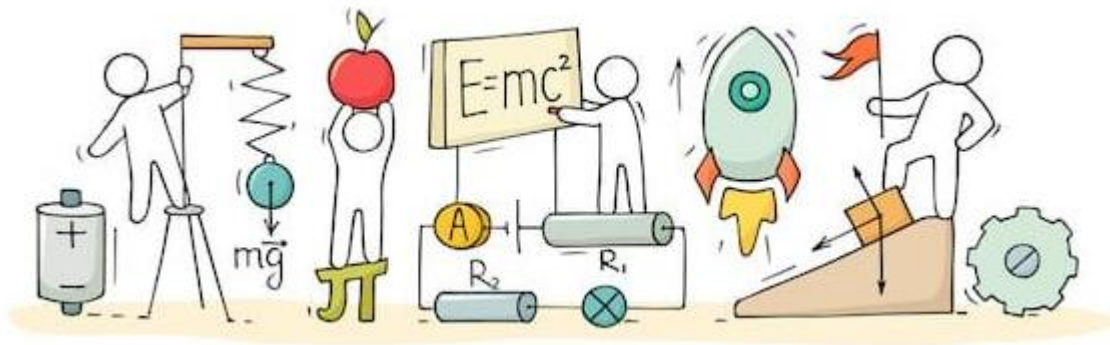

WAVE OPTICS

Wave Optics:

Wave optics also called Physical optics deals with the study of various phenomena such as polarization, diffraction, interference, and other occurrences where ray approximation of geometric optics cannot be done. Thus, the section of optics that deals with the behaviour of light and its wave characteristics is said to be wave optics.

Wave Front:

The locus of all those particles which are vibrating in the same phase at any instant is called wave front. Thus, wave front is a surface having same phase of vibrating particles at any instant at every point on it.

These are three types:

- Spherical wavefront
- Cylindrical wavefront
- Plane wavefront

Models of Light:

Corpuscular model: According to this model, a luminous body emits a stream of particles in all directions. The particles are assumed to be very-very tiny. It explained the laws of reflection and refraction of light at an interface using concepts of elastic collisions and momentum conservation. Although this law could explain reflection and refraction, this law could not satisfactorily explain phenomenon like interference, polarization, and diffraction. In 1637, Descartes gave the corpuscular model of light.

Wave model: The wave theory of light was first put forward by Christian Huygen in 1678. On the basis of his wave theory, Huygen explained satisfactorily the phenomenon of reflection, refraction and total internal reflection.

Huygens's Principle:

Huygens's principle is a geometrical construction, which can be used to obtain new position of a wave front at a later time from its given position at any instant. Or we can quote that this principle gives a method gives an idea about how light spreads out in the medium.

It is developed on the following assumptions:

- All the points on a given or primary wave front acts as a source of secondary wavelets, which sends out disturbance in all directions in a similar manner as the primary light source.
- The new position of the wave front at any instant (called secondary wave front) is the envelope of the secondary wavelets at that instant.

These two assumptions are known as Huygens principle or Huygens' construction.

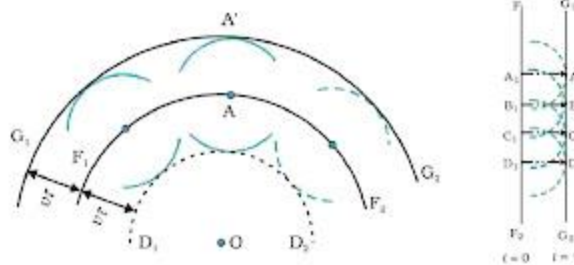

Maxwell's Electromagnetic Wave Theory:

- Light waves are electromagnetic waves which do not require a material medium for their propagation.
- Due to transverse nature, light wave undergo polarization.
- The velocity of electromagnetic wave in vacuum is $c = \frac{1}{\mu_0 \epsilon_0}$
- The velocity of electromagnetic waves in medium is less than that of light, $v < c$

$$v = \frac{1}{\sqrt{\mu_0 \epsilon_0 \epsilon_r \mu_r}} = \frac{c}{\sqrt{\mu_r \epsilon_r}}$$
- The velocity of electromagnetic waves in a medium depend upon the electric and magnetic properties of the medium.

where, μ_0 = absolute magnetic permeability and

ϵ_0 = absolute electrical permittivity of free space.

- It failed to explain the phenomenon of photoelectric effect, Compton effect and Raman effect.

Max Planck's Quantum Theory:

- Light emits from a source in the form of packets of energy called quanta or photon.
- The energy of a photon is $E = h\nu$, where h is Planck's constant and ν is the

frequency of light.

- Quantum theory could explain photoelectric effect, Compton effect and Raman effect.
- Quantum theory failed to explain interference, diffraction and polarization of light.

The Doppler's Effect:

When light producing source moves away from the observer the frequency as measured by the observer will be smaller than that is actually generated by the source. Astronomers call the increase in wavelength due to Doppler effect as red shift.

When observer moves towards the source or the source moves towards observer, then apparent wavelength decreases, and visible spectrum appear to be shifted towards shorter wavelength. Hence, we call this as blue shift.

Coherent and Incoherent Sources of Light:

- **Coherent sources:** Two sources of light which continuously emit light waves of same frequency (or wavelength) with a zero or constant phase difference between them, are called coherent sources. Ex- LASER.
- **Incoherent sources:** Two sources of light which do not emit light waves with a constant phase difference are called incoherent sources. Ex- Two different light sources produce incoherent waves.

Interference of Light Wave:

Interference is the phenomenon in which two waves superpose to form the resultant wave of the lower, higher or same amplitude. When the crest of one wave falls on the crest of another wave such that the amplitude is maximum then interference is called constructive interference. When the crest of one wave falls on the trough of another wave such that the amplitude is minimum then interference is called destructive interference.

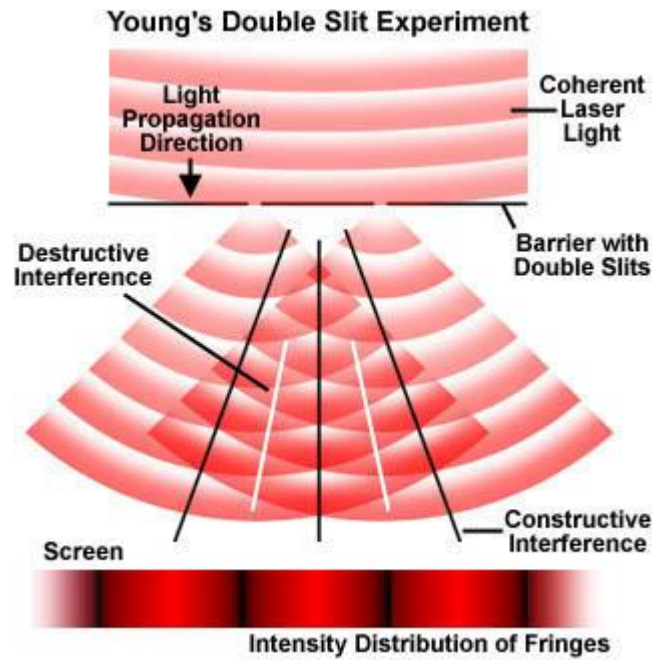

Conditions for sustained interference:

- Two sources of light must be coherent.
- The frequencies (or wavelength) of the two waves should be equal.
- The light must be monochromatic.
- The amplitudes of the interfering waves must be equal or nearly equal.
- The two sources must be narrow.

Diffraction: The phenomenon of bending of light around the corners of an obstacle is called the diffraction of light.

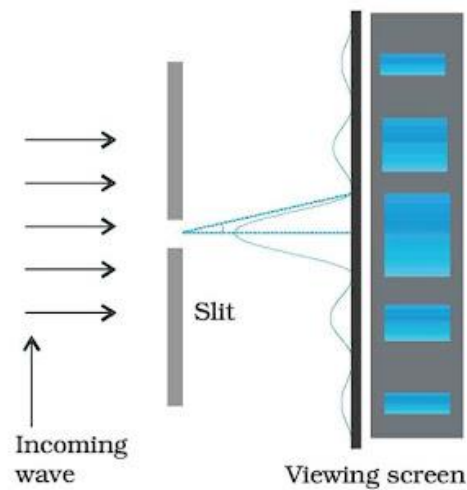

Difference between Diffraction and Interference:

S. No.	Interference	Diffraction
1.	Interference may be defined as waves emerging from two different sources, producing different wavefronts.	Diffraction, on the other hand, can be termed as secondary waves that emerge from the different parts of the same wave.
2.	The intensity of all the points on maxima is of similar intensity in interference.	In diffraction, there is a variance of the intensity of positions.
3.	It is absolutely dark in the region of minimum intensity, in the case of interference.	We see a variance in the intensity of interference in diffraction.
4.	The width of the fringes in interference is equal in interference.	The width of the fringes is not equal in interference.
5.	The sources are referred to as interference sources if the number of sources is as few as two sources.	If the number of sources is more than to the sources are referred to as diffraction sources.

Polarization: If the vibrations of a wave are present in just one direction in a plane perpendicular to the direction of propagation, the wave is said to be polarized or plane polarised. The phenomenon of restricting the oscillations of a wave to just one direction in the transverse plane is called polarization of waves.

Malus' Law: It states that the intensity of plane-polarized light that passes through an analyzer varies directly with the square of the cosine of the angle between the plane of the polarizer and the transmission axes of the analyzer.

$$I = I_0 \cos^2 \theta$$

Polarizer: A device that polarizes the unpolarized light passed through it is called a polarizer.

Optical Activity: When plane polarized light passes through a certain substances, the plane of polarization of the light is rotated about the direction of propagation of light through a certain angle. This phenomenon is called optical activity or optical rotation and the substances optically active.

Brewster's Law:

According to Brewster's law, when an unpolarized light is incident on a transparent substance surface, it experiences maximum plan polarization at the angle of incidence whose tangent is the refractive index of the substance for the wavelength.

$$n = \tan i \text{ (where, } i = \text{incident angle)}$$

Double Refraction:

When unpolarized light is incident on a calcite or quartz crystal it splits up into two refracted rays. one of which follows laws of refraction. called ordinary ray (O-ray) and other do not follow laws of refraction. called extraordinary ray (E-ray). This phenomenon is called double refraction.

Dichroism:

Few double refracting crystals have a property of absorbing one of the two refracted rays and allowing the other to emerge out. This property of crystal is called dichroism.

Polaroid:

It is a polarizing film mounted between two glass plates. It is used to produce polarized light.

A polaroid is used to avoid glare of light in spectacles.

Uses of Polaroid:

- Polaroids are used in sunglasses. They protect the eyes from glare.
- The polaroid's are used in window panes of a train and especially of an aero plane. They help to control the light entering through the window.
- The windshield of an automobile is made of polaroid. Such a wind shield protects the eyes of the driver of the automobile from the dazzling light of the approaching vehicles.
- The pictures taken by a stereoscopic camera. When seen with the help of polarized spectacles, create three-dimensional effect.

Nicol Prism: A Nicol prism is an optical device which is used for producing plane polarised light and analyzing light the same.

The Nicol prism consists of two calcite crystal cut at 68° with its principal axis joined by a glue called Canada balsam.

Validity of Ray Optics: By diffraction of light travels, a parallel beam of light travels up to distances as large as few meters can be broadened.

Fresnel Distance: The minimum distance a beam of light can travel before its deviation from straight line path becomes significant/ noticeable is known as Fresnel distance.

$$Z_F = \frac{a^2}{\lambda}$$

As the wavelength of light is very small, the deviation will be also very small, and light can be assumed as travelling in a straight line.

So, we can neglect broadening of beam due to diffraction up to distances as large as a few meters, i.e., we can assume that light travels along straight lines and ray optics can be taken as a limiting case of wave optics.

Therefore, Ray optics can be considered as a limiting case of wave optics.

Resolving Power:

If two point objects are close to each other, images diffraction patterns of those objects will also be close and overlap each other.

Limit of resolution of the instrument is the minimum distance between two objects which can be seen separately by the object instrument.

$$\text{Resolving Power (R.P)} = \frac{1}{\text{Limit of Revolution}}$$

Resolving power of Microscope:

$$\text{R.P. of microscope} = \frac{2\mu \sin \theta}{\lambda}$$

Where D is the aperture of the telescope.

Class : 12th Physics
Chapter- 10 : Wave Optics

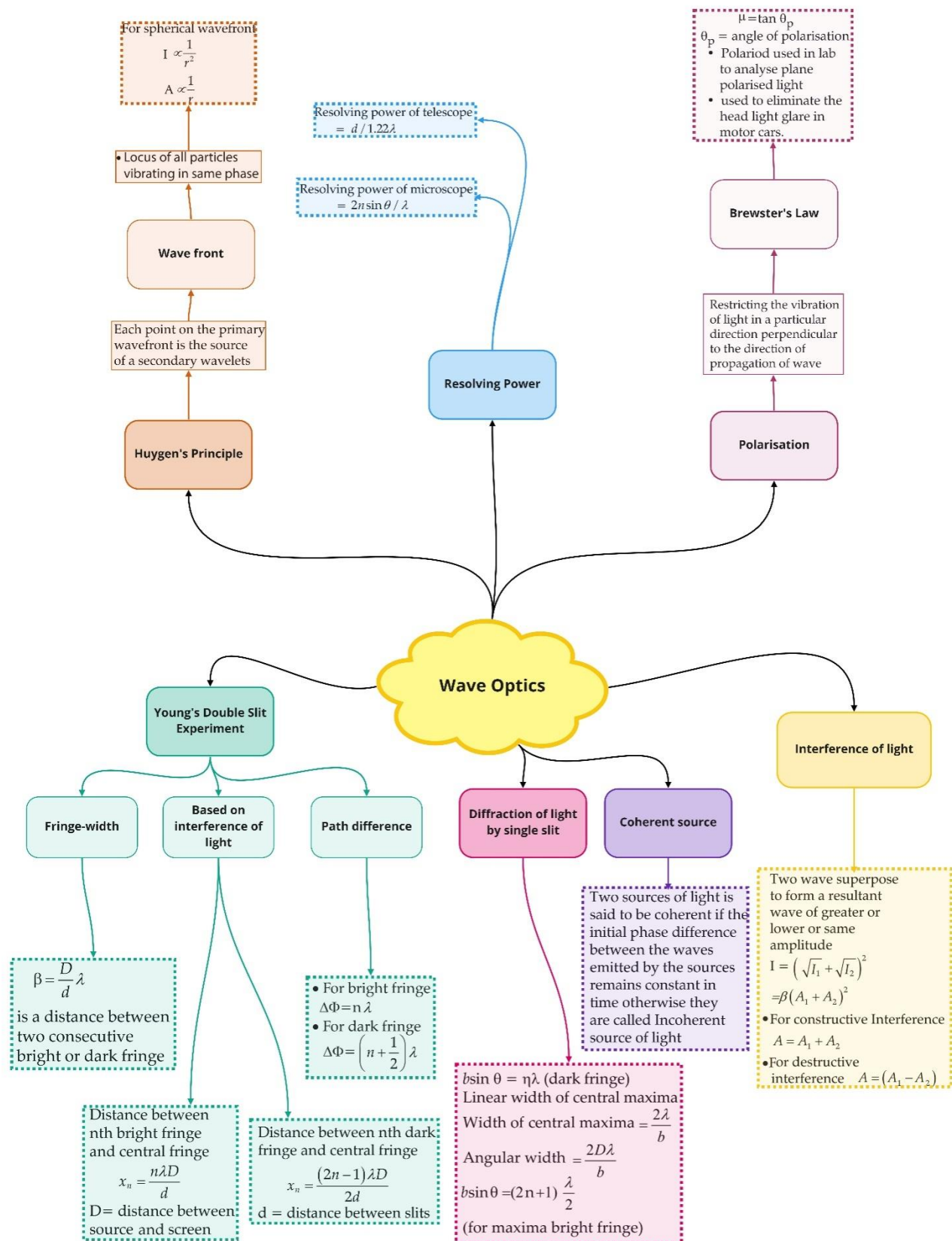

Important Questions

Multiple Choice questions-

- The idea of secondary wavelets for the propagation of a wave was first given by
 - Newton
 - Huygens
 - Maxwell
 - Fresnel
- Light propagates rectilinearly, due to
 - wave nature
 - wavelengths
 - velocity
 - frequency
- Which of the following is correct for light diverging from a point source?
 - The intensity decreases in proportion with the distance squared.
 - The wavefront is parabolic.
 - The intensity at the wavelength does not depend on the distance.
 - None of these.
- The refractive index of glass is 1.5 for light waves of $\lambda = 6000 \text{ \AA}$ in vacuum. Its wavelength in glass is
 - 2000 \AA
 - 4000 \AA
 - 1000 \AA
 - 3000 \AA
- The phenomena which is not explained by Huygen's construction of wavefront
 - reflection
 - diffraction
 - refraction
 - origin of spectra
- A laser beam is used for locating distant objects because
 - it is monochromatic
 - it is not chromatic
 - it is not observed
 - it has small angular spread.
- Two slits in Young's double slit experiment have widths in the ratio 81 :1. The ratio of the amplitudes of light waves is

- (a) 3 :1
- (b) 3 : 2
- (c) 9 :1
- (d) 6:1

8. When interference of light takes place

- (a) energy is created in the region of maximum intensity
- (b) energy is destroyed in the region of maximum intensity
- (c) conservation of energy holds good and energy is redistributed
- (d) conservation of energy does not hold good

9. In a double slit interference pattern, the first maxima for infrared light would be

- (a) at the same place as the first maxima for green light
- (b) closer to the center than the first maxima for green light
- (c) farther from the center than the first maxima for green light
- (d) infrared light does not produce an interference pattern

10. To observe diffraction, the size of the obstacle

- (a) should be $X/2$, where X is the wavelength.
- (b) should be of the order of wavelength.
- (c) has no relation to wavelength.
- (d) should be much larger than the wavelength.

Very Short:

1. Sketch the refracted wavefront emerging from convex lens, if a plane wavefront is incident normally on it.
2. How would you explain the propagation of light on the basis of Huygen's wave theory?
3. Draw the shape of the reflected wavefront when a plane wavefront is incident on a concave mirror.
4. Draw the shape of the refracted wavefront when a plane wavefront is incident on a prism.
5. Draw the type of wavefront that corresponds to a beam of light diverging from a point source.
6. Draw the type of wavefront that corresponds to a beam of light coming from a very far off source.
7. Name two phenomena that establish the wave nature of light.
8. State the conditions which must be satisfied for two light sources to be coherent.

9. Draw an intensity distribution graph for diffraction due to a single slit.
10. Name one device for producing plane polarised light. Draw the graph showing the variation of intensity of polarised light transmitted by an analyser.

Short Questions:

1. How can one distinguish between an unpolarised and linearly polarised light beam using polaroid? (CBSE Delhi 2019)
2. What is meant by plane polarised light? What type of waves shows the property of polarisation? Describe a method of producing a beam of plane polarised light?
3. Write the Important characteristic features by which the Interference can be distinguished from the observed diffraction pattern. (CBSE AI 2015)
4. State Brewster's law. The value of Brewster's angle for the transparent medium is different for the light of different colours. Give reason. (CBSE Delhi 2016)
5. Discuss the intensity of transmitted light when a polaroid sheet is rotated between two crossed polaroid's.
6. Is energy conserved in interference? Explain.
7. An incident beam of light of intensity I_0 is made to fall on a polaroid A. Another polaroid B is so oriented with respect to A that there is no light emerging out of B. A third polaroid C is now introduced midway between A and B and is so oriented that its axis bisects the angle between the axis of A and B. What is the intensity of light now between (i) A and C (ii) C and B? Give reasons for your answers.
8. One of the slits of Young's double-slit experiment is covered with a semi-transparent paper so that it transmits lesser light. What will be the effect on the interference pattern?

Long Questions:

1. Define the term wavefront. Using Huygen's wave theory, verify the law of reflection.

Or

Define the term, "refractive index" of a medium. Verify Snell's law of refraction when a plane wavefront is propagating from a denser to a rarer medium. (CBSE Delhi 2019)

2.

(a) Sketch the refracted wavefront for the incident plane wavefront of the light from a distant object passing through a convex lens.

(b) Using Huygens's principle, verify the laws of refraction when light from a denser medium is incident on a rarer medium.

(c) For yellow light of wavelength 590 nm incident on a glass slab, the refractive index of glass is 1.5. Estimate the speed and wavelength of yellow light inside the glass slab. (CBSE 2019C)

Assertion and Reason Questions-

1. For question two statements are given-one labelled Assertion (A) and the other labelled Reason (R). Select the correct answer to these questions from the codes (a), (b), (c) and (d) as given below.

- a) Both A and R are true and R is the correct explanation of A.
- b) Both A and R are true but R is NOT the correct explanation of A.
- c) A is true but R is false.
- d) A is false and R is also false.

Assertion (A): When tiny circular obstacle is placed in the path of light from some distance, a bright spot is seen at the centre of the shadow of the obstacle.

Reason (R): Destructive interference occurs at the centre of the shadow.

2. For question two statements are given-one labelled Assertion (A) and the other labelled Reason (R). Select the correct answer to these questions from the codes (a), (b), (c) and (d) as given below.

- a) Both A and R are true and R is the correct explanation of A.
- b) Both A and R are true but R is NOT the correct explanation of A.
- c) A is true but R is false.
- d) A is false and R is also false.

Assertion (A): One of the conditions for interference is that the two sources should be very narrow.

Reason (R): One broad source is equal to a large number of narrow sources.

Case Study Questions-

1. The phenomenon of bending of light around the sharp corners and the spreading of light within the geometrical shadow of the opaque obstacles is called diffraction of light. The light thus deviates from its linear path. The deviation becomes much more pronounced, when the dimensions of the aperture or the obstacle are comparable to the wavelength of light.

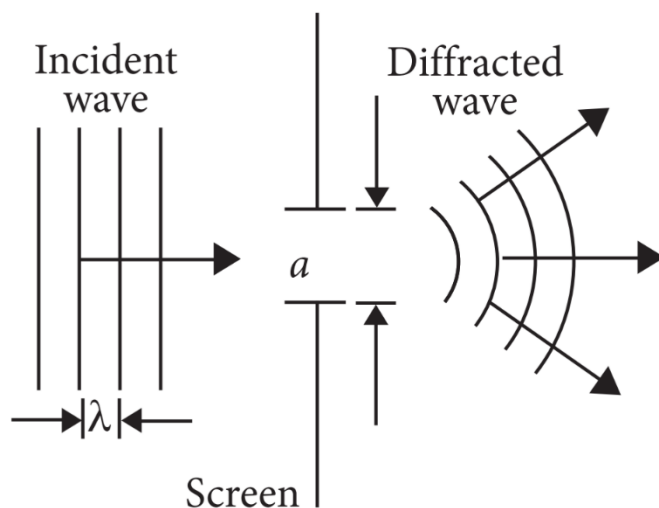

- (i) Light seems to propagate in rectilinear path because.
- Its spread is very large.
 - Its wavelength is very small.
 - Reflected from the upper surface of atmosphere.
 - It is not absorbed by atmosphere.
- (ii) In diffraction from a single slit the angular width of the central maxima does not depends on:
- λ of light used.
 - Width of slit.
 - Distance of slits from the screen.
 - Ratio of λ and slit width.
- (iii) For a diffraction from a single slit, the intensity of the central point is:
- Infinite.
 - Finite and same magnitude as the surrounding maxima.
 - Finite but much larger than the surrounding maxima.
 - Finite and substantially smaller than the surrounding maxima.
- (iv) Resolving power of telescope increases when:
- Wavelength of light decreases.
 - Wavelength of light increases.
 - Focal length of eye-piece increases.
 - Focal length of eye-piece decreases.
- (v) In a single diffraction pattern observed on a screen placed at D metre distance from the slit of width d metre, the ratio of the width of the central maxima to the width of other secondary maxima is:
- 2 : 1
 - 1 : 2

- c) 1 : 1
- d) 3 : 1

2. Huygen's principle is the basis of wave theory of light. Each point on a wavefront acts as a fresh source of new disturbance, called secondary waves or wavelets. The secondary wavelets spread out in all directions with the speed light in the given medium.

An initially parallel cylindrical beam travels in a medium of refractive index $\mu(I) = \mu_0 + \mu_2 I$, where μ_0 and μ_2 are positive constants and I is the intensity of the light beam. The intensity of the beam is decreasing with increasing radius.

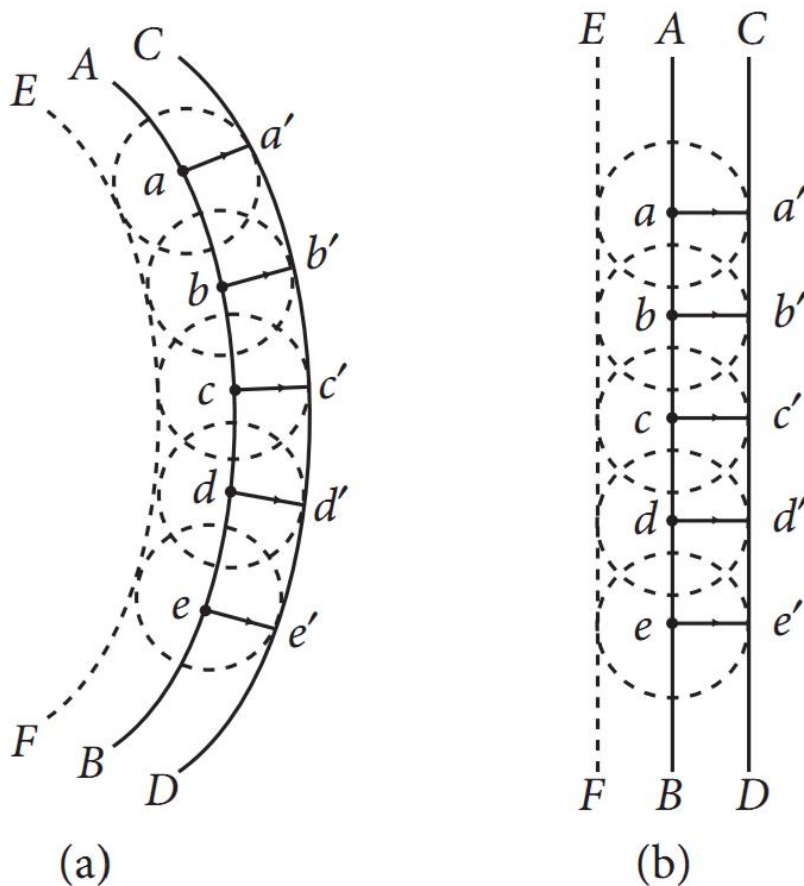

(i) The initial shape of the wavefront of the beam is:

- a) Planar.
- b) Convex.
- c) Concave.
- d) Convex near the axis and concave near the periphery.

(ii) According to Huygens Principle, the surface of constant phase is:

- a) Called an optical ray.
- b) Called a wave.
- c) Called a wavefront.

- d) Always linear in shape.
- (iii) As the beam enters the medium, it will:
- Travel as a cylindrical beam.
 - Diverge.
 - Converge.
 - Diverge near the axis and converge near the periphery.
- (iv) Two plane wavefronts of light, one incident on a thin convex lens and another on the refracting face of a thin prism. After refraction at them, the emerging wavefronts respectively become.
- Plane wavefront and plane wavefront.
 - Plane wavefront and spherical wavefront.
 - Spherical wavefront and plane wavefront.
 - Spherical wavefront and spherical wavefront.
- (v) Which of the following phenomena support the wave theory of light?
- Scattering.
 - Interference.
 - Diffraction.
 - Velocity of light in a denser medium is less than the velocity of light in the rarer medium.
- 1, 2, 3
 - 1, 2, 4
 - 2, 3, 4
 - 1, 3, 4

✓ Answer Key:

Multiple Choice Answers-

- Answer: b
- Answer: a
- Answer: a
- Answer: b
- Answer: d
- Answer: d
- Answer: c
- Answer: c
- Answer: c

10. Answer: b

Very Short Answers:

1. Answer: The figure is as shown.

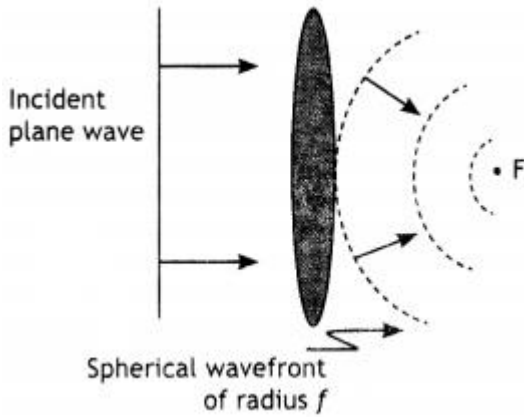

2. Answer: To explain the propagation of light we have to draw a wavefront at a later instant when a wavefront at an earlier instant is known. This can be drawn by the use of Huygen's principle.

3. Answer: The reflected wavefront is as shown.

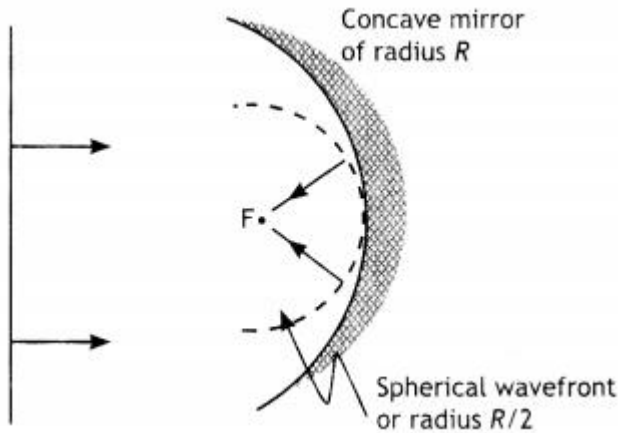

4. Answer: The shape of the wavefront is as shown.

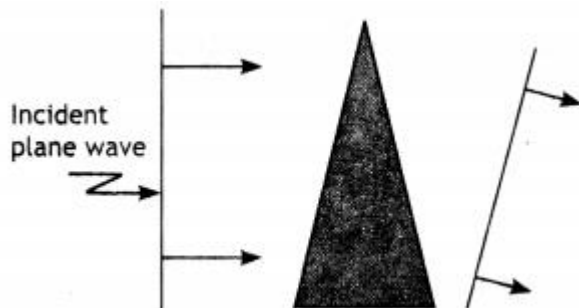

5. Answer: The wavefront formed by the light coming from a very far off source is a

plane and for a beam of light diverging from a point, a wavefront is a number of concentric circles.

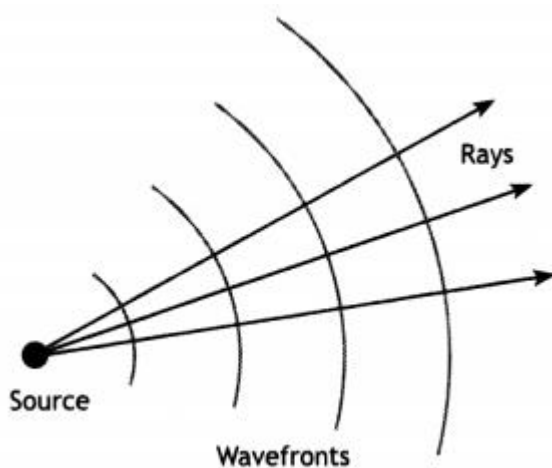

6. Answer: The wavefront is as shown.

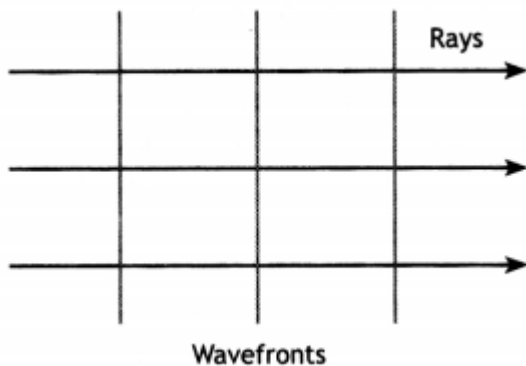

7. Answer: Interference and diffraction of light.

8. Answer:

(a) Two sources must emit light of the same wavelength (or frequency).

(b) The two light sources must be either in-phase or have a constant phase difference.

9. Answer:

The intensity distribution for a single-slit diffraction pattern is as shown.

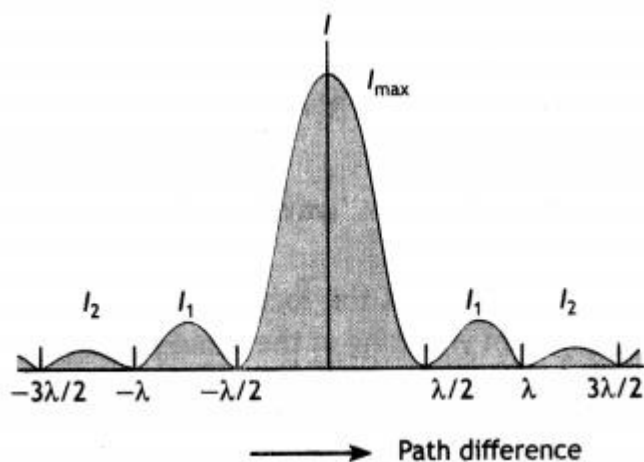

10. Answer: Nicol prism can be used to produce plane polarised light. The graph is as shown.

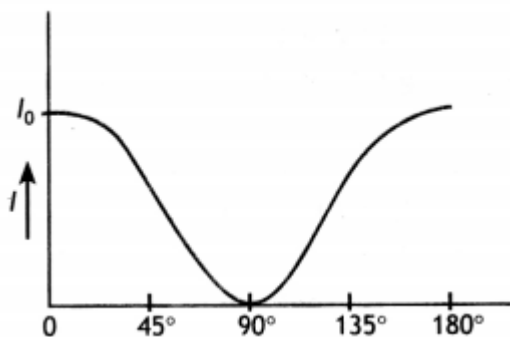

Short Questions Answers:

- Answer: The two lights will be allowed to pass through a polariser. When the polarizer is rotated in the path of these two light beams, the intensity of light remains the same in all the orientations of the polariser, then the light is unpolarised. But if the intensity of light varies from maximum to minimum then the light beam is a polarised light beam.
- Answer:
 - The light that has its vibrations restricted in only one plane is called plane polarised light.
 - Transverse waves show the phenomenon of polarization.
Light is allowed to pass through a polaroid. The polaroid absorbs those vibrations which are not parallel to its axis and allows only those vibrations to pass which are parallel to its axis.
- Answer:
 - In the interference pattern the bright fringes are of the same width, whereas in the diffraction pattern they are not of the same width.

(b) In interference all bright fringes are equally bright while in diffraction they are not equally bright.

4. Answer:

When the reflected ray and the refracted ray are perpendicular then $\mu = \tan i_p$ where i_p is the polarising angle or Brewster angle.

Brewster's angle depends upon the refractive index of the two media in contact. The refractive index in turn depends upon the wavelength of light used (different colours) hence Brewster's angle is different for different colours.

5. Answer:

Let I_0 be the intensity of polarised light after passing through the first polarizer P_1 . Then the intensity of light after passing through the second polarizer P_2 will be $I = I_0 \cos^2 2\theta$, where θ is the angle between pass axes of P_1 and P_2 . Since P_1 and P_3 are crossed the angle between the pass axes of P_2 and P_3 will be $(\pi/2 - \theta)$. Hence the intensity of light emerging from P_3 will be

$$I = I_0 \cos^2 \theta \cos^2 (90^\circ - \theta) = I_0 \cos^2 \theta \sin^2 \theta = (I_0 / 4) \sin^2 2\theta$$

Therefore, the transmitted intensity will be maximum when $\theta = \pi/4$

6. Answer:

Yes, energy is conserved in interference. Energy from the dark fringes is accumulated in the bright fringes. If we take

$I = 4a^2 \cos^2 \frac{\phi}{2}$, then intensity at bright points is $I_{\max} = 4a^2$ and intensity at the minima $I_{\min} = 0$. Hence average intensity in the pattern of the fringes produced due to interference is given by

$$\bar{I} = \frac{I_{\max} + I_{\min}}{2} = \frac{4a^2 + 0}{2} = 2a^2$$

But if there is no interference then total intensity at every point on the screen will be $I = a^2 + a^2 = 2a^2$, which is the same as the average intensity in the interference pattern.

7. Answer: Polaroids A and B are oriented at an angle of 90° , so no light is emerging out of B. On placing polaroid C between A and B such that its axis bisects the angle between axes of A and B, then the angle between axes of polaroids A and B is 45° and that of C and B also 45° .

(a) Intensity of light on passing through Polaroid A or between A and C is $I_1 = \frac{I_0}{2}$

(b) On passing through polaroid C, intensity of light between C and B becomes

$$I_2 = I_1 \cos^2 \theta = \frac{I_0}{2} \times \cos^2 45^\circ = \frac{I_0}{4}$$

8. Answer: There will be an interference pattern whose fringe width is the same as that of the original. But there will be a decrease in the contrast between the

maxima and the minima, i.e., the maxima will become less bright, and the minima will become brighter.

Long Questions Answers:

1. Answer:

The wavefront is a locus of points that oscillate in the same phase.

Consider a plane wavefront AB incident obliquely on a plane reflecting surface MM' . Let us consider the situation when one end A of wave front strikes the mirror at an angle i but the other end B has still to cover distance BC . The time required for this will be $t = BC/c$.

According to Huygen's principle, point A starts emitting secondary wavelets and in time t , these will cover a distance $ct = BC$ and spread. Hence, with point A as centre and BC as radius, draw a circular arc. Draw tangent CD on this arc from point C . Obviously, the CD is the reflected wavefront inclined at an angle ' r '. As incident wavefront and reflected wavefront, both are in the plane of the paper, the 1st law of reflection is proved.

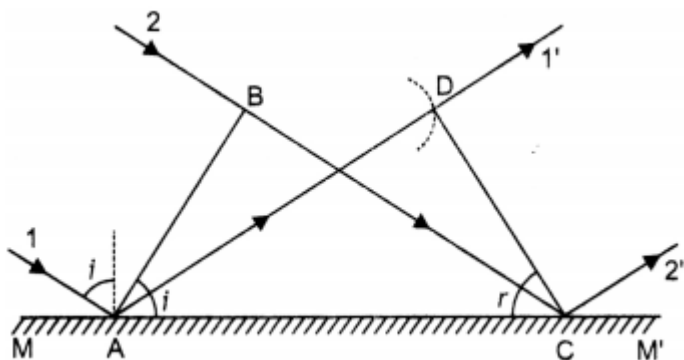

To prove the second law of reflection, consider $\triangle ABC$ and $\triangle ADC$. $BC = AD$ (by construction),

$\angle ABC = \angle ADC = 90^\circ$ and AC is common.

Therefore, the two triangles are congruent and, hence, $\angle BAC = \angle DCA$ or $\angle i = \angle r$, i.e. The angle of reflection is equal to the angle of incidence, which is the second law of reflection.

Or

The refractive index of medium 2, w.r.t. medium 1 equals the ratio of the sine of the angle of incidence (in medium 1) to the sine of the angle of refraction (in medium 2), The diagram is as shown.

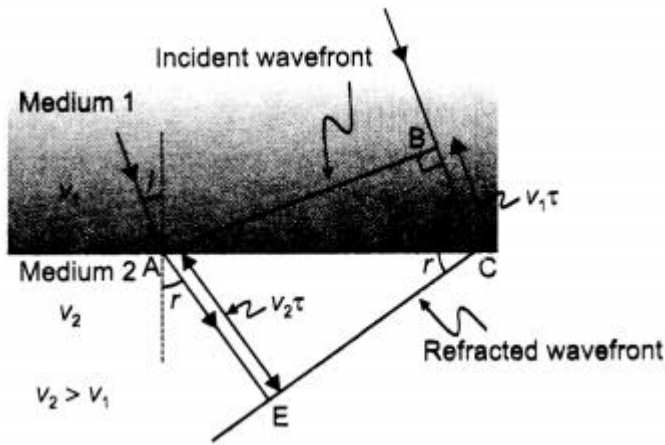

From the diagram

$$\sin i = \frac{BC}{AC} = \frac{v_1 \tau}{AC}$$

$$\text{And } \sin r = \frac{AE}{AC} = \frac{v_2 \tau}{AC}$$

$$\text{Therefore, } \frac{\sin i}{\sin r} = \frac{v_1}{v_2} = n_{12}$$

2. Answer:

(a) Refracted wavefront

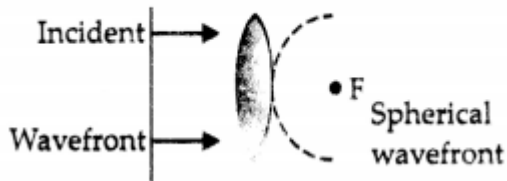

(b) Refraction from denser to the rarer medium: Let XY be plane refracting surface separating two media of refractive index μ_1 and μ_2 ($\mu_1 > \mu_2$)

Let a plane wavefront AB incident at an angle i . According to Huygen's principle, each point on the wavefront becomes a source of secondary wavelets and

Time is taken by wavelets from B to C = Time taken by wavelets from A to D

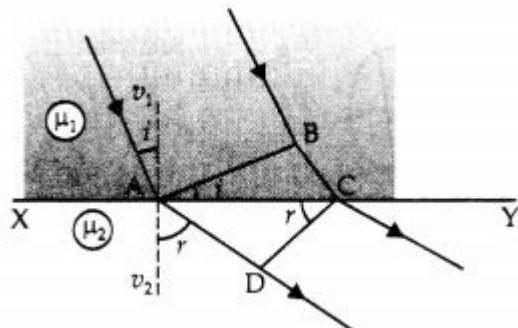

$$\text{i.e. } t = \frac{BC}{v_1} = \frac{AD}{v_2}$$

$$\text{or } \frac{BC}{AD} = \frac{v_1}{v_2} \quad \dots(i)$$

In right angle $\triangle ABC$

$$\frac{BC}{AC} = \sin i$$

$$\text{or } BC = AC \sin i \quad \dots(ii)$$

Similarly, in right angle $\triangle ADC$

$$AD = AC \sin r \quad \dots(iii)$$

From (ii) and (iii)

$$\frac{BC}{AD} = \frac{\sin i}{\sin r}$$

From (i) and (ii), we have

$$\frac{\sin i}{\sin r} = \frac{v_1}{v_2} = {}^1\mu_2$$

(c)

Given $\lambda = 590 \text{ nm}$, $\mu = 1.5$

Velocity of light inside glass slab.

$$\therefore v = \frac{C}{\mu} = \frac{3 \times 10^8}{1.5} = 2 \times 10^8 \text{ ms}^{-1}$$

Wavelength of yellow light inside the glass slab.

$$\lambda_1 = \frac{\lambda}{\mu} = \frac{290}{1.5} = 393.33 \text{ nm}$$

Assertion and Reason Answers-

1. (c) A is true but R is false.

Explanation:

The waves diffracted from the edges of circular obstacle, placed in the path of light, interfere constructively at the centre of the shadow resulting in the formation of a bright spot.

2. (a) Both A and R are true and R is the correct explanation of A.

Explanation:

As a broad source is equivalent to a large number of narrow sources lying side by side. Each set of these sources will produce an interference pattern of its own which will

overlap on another to such an extent that all traces of a fringe system is lost and results in general illumination. Because of this reason, for interference a narrow slit should be used.

Case Study Answers-

1. Answer :

(i) (b) Its wavelength is very small.

Explanation:

The wavelength of visible light is very small, that is hardly shows diffraction, so it seems to propagate in rectilinear path,

(ii) (c) Distance of slits from the screen.

Explanation:

Angular width of central maxima, $2\theta = \frac{2\lambda}{e}$.

Thus, θ does not depend on screen i.e., distance between the slit and the screen.

(iii) (c) Finite but much larger than the surrounding maxima.

Explanation:

diffraction pattern is shown in the figure. From the graph it is clear that the intensity of the central point is finite but much larger than the surrounding maxima.

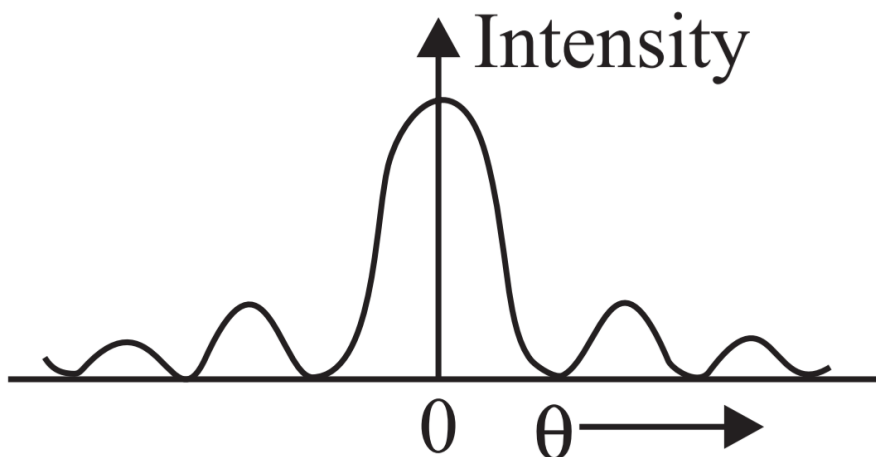

(iv) (a) Wavelength of light decreases.

Explanation:

Resolving power of telescope $= \frac{a}{1.22\lambda}$

\therefore It increases when wavelength of light decreases and/or objective lens of greater diameter is used.

(v) (a) 2 : 1

Explanation:

$$\text{Width of central maxima} = \frac{2\lambda D}{e}$$

$$\text{width of other secondary maxima} = \frac{\lambda D}{e}$$

∴ Width of central maxima: width of other secondary maxima
= 2 : 1

2. Answer :

(i) (a) Planar.

Explanation:

As the beam is initially parallel, the shape of wavefront is planar.

(ii) (c) Called a wavefront.

Explanation:

According to Huygens Principle, the surface of constant phase is called a wavefront.

(iii) (c) Converge.

(iv) (c) Spherical wavefront and plane wavefront.

Explanation:

After refraction, the emerging wavefronts respectively become spherical wavefront and plane wavefront as shown in figures (a) and (b).

Incident plane wavefront	Spherical wavefront	Incident plane wavefront	Plane wavefront
-----------------------------	------------------------	-----------------------------	--------------------

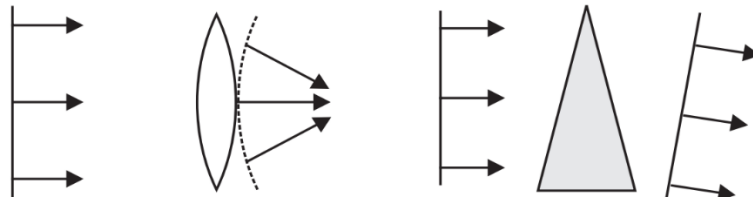

(a)

(b)

(v) (c) 2, 3, 4



C V RAMAN
P U C O L L E G E
I N D I

CHAPTER 11: DUAL NATURE OF RADIATION AND MATTER

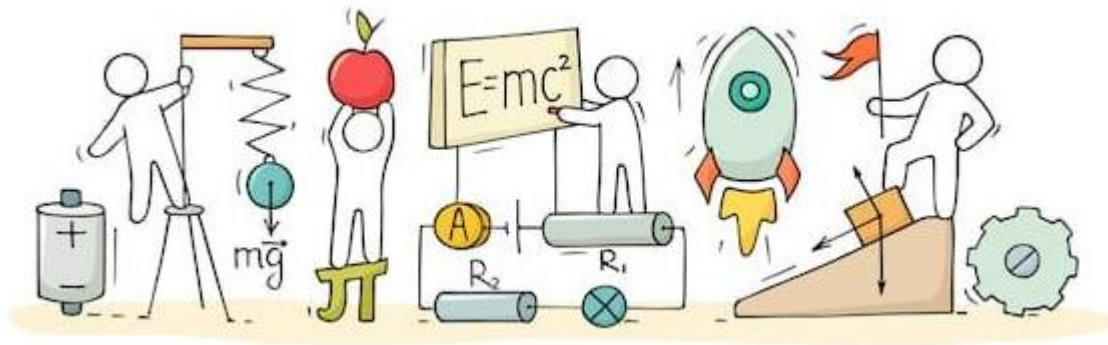

DUAL NATURE OF RADIATION AND MATTER

Electron emission:

The phenomenon of emission of electrons from the surface of a metal. The minimum energy needed by an electron to come out from a metal surface is known as “work function” of the metal. It is denoted by Φ_0 or W_0 and measured in electron volt (eV).

$$\text{Work function } W = hv = \frac{hc}{\lambda}$$

The electron emission can be obtained from the following physical processes:

Thermionic emission: It is the phenomenon of emission of electrons from the metal surface when heated suitably.

Photoelectric emission: It is the phenomenon of emission of electrons from the surface of metal when light radiations of suitable frequency fall on it.

Field emission or cold cathode emission: It is the phenomenon of emission of electrons from the surface of a metal under the application of a strong electric field.

Photoelectric effect: It is the phenomenon of emission of electrons from the surface of metals when light radiations of suitable frequency fall on them.

Work Function:

To pull out electron from the surface of the metal, a certain minimum amount of energy is required. This minimum energy required by the electron is called the work function of the metal. Work function is generally denoted by 'w' and measured in eV (electron volt).

Threshold Frequency:

The minimum frequency of light which can emit photoelectrons from a material is called threshold frequency or cut-off frequency of that material.

Threshold Wavelength:

The maximum wavelength of light which can emit photoelectrons from a material is called threshold wavelength or cut-off wavelength of that material.

Electron Volt: One electron volt is the energy acquired by an electron, when it has been accelerated by 1-volt potential difference. ($1 \text{ eV} = 1.602 \times 10^{-19} \text{ J}$).

Photoelectric Effect:

The phenomenon of emission of photoelectron from the surface of metal, when a light beam of suitable frequency is incident on it, is called photoelectric effect. The emitted electrons are called photoelectrons and the current so produced is called photoelectric current.

Laws of Photoelectric Effect:

- For a given metal and a radiation of fixed frequency, the number of photoelectrons emitted is proportional to the intensity of incident radiation.
- For every metal, there is a certain minimum frequency below which no photoelectrons are emitted, howsoever high is the intensity of incident radiation. This frequency is called threshold frequency.
- For the radiation of frequency higher than the threshold frequency, the maximum kinetic energy of the photoelectrons is directly proportional to the frequency of incident radiation and is independent of the intensity of incident radiation.
- The photoelectric emission is an instantaneous process.

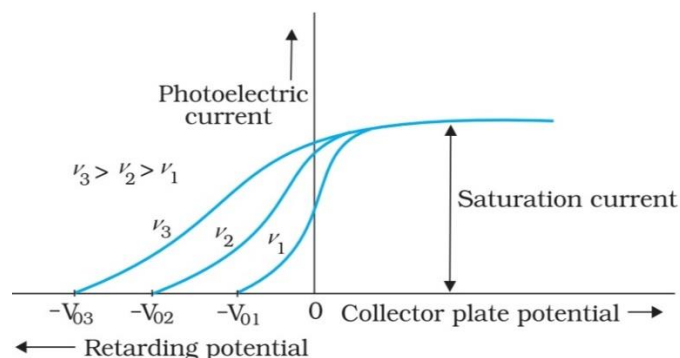
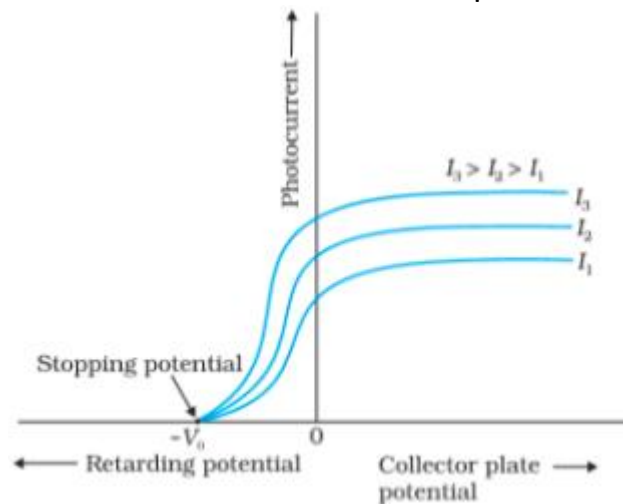

Hertz' Observation: The phenomenon of photo electric emission was discovered in 1887

by Heinrich Hertz during his electromagnetic wave experiment. In his experimental investigation on the production of electromagnetic waves by means of spark across the detector loop were enhanced when the emitter plate was illuminated by ultraviolet light from an arc lamp.

Lenard's Observation: Lenard observed that when ultraviolet radiation was allowed to fall on emitter plate of an evacuated glass tube enclosing two electrodes, current flows. As soon as, the ultraviolet radiations were stopped, the current flows also stopped.

These observations indicate that when ultraviolet radiations fall on the emitter plate, electrons are ejected from it which are attracted towards the positive plate by the electric field.

Cathode Rays:

Cathode rays are the stream of fast-moving electrons. These rays are produced in a discharge tube at a pressure below 0.01 mm of mercury.

Properties of Cathode Rays:

- Cathode rays are not electromagnetic rays.
- Cathode rays are deflected by electric field and magnetic field.
- Cathode rays produce heat in metals when they fall on them.
- Cathode rays can pass through thin aluminium or gold foils without puncturing them.
- Cathode rays can produce physical and chemical change.
- Cathode rays travel in straight line with high velocity momentum and energy and cast shadow of objects placed in their path.
- On striking the target of high atomic weight and high melting point, they produce X-rays.
- Cathode rays produce fluorescence and phosphorescence in certain substance and hence affect photographic plate.

Positive Rays:

Positive rays were discovered by Goldstein. Positive rays are moving positive ions of gas filled in the discharge tube. The mass of these particles is nearly equal to the mass of the atoms of gas.

- These consist of fast moving positively charged particles.
- These rays are deflected in magnetic and electric fields.
- These rays travel in straight line.

- Speed of positive rays is less than that of cathode rays.
- These rays can produce fluorescence and phosphorescence.

Dual nature of radiation:

Wave theory of electromagnetic radiation explains the phenomenon of interference, diffraction, and polarization. On the other hand, photoelectric effect is supported by particle nature of light. Hence, we assume dual nature of light.

Einstein's Photoelectric Equation:

To explain photoelectric effect in 1905, Albert Einstein proposed completely different picture of electromagnetic radiation. In this picture radiation energy is built up of discrete units and photoelectric emission does not take place by continuous absorption of energy from radiation. These discrete units are called quanta of energy of radiation. Each quantum of energy is $h\nu$, where ν is the frequency of light and h is Planck's constant.

In photoelectric effect, an electron absorbs a quantum of energy ($h\nu$) of radiation. If this absorbed energy exceeds the minimum energy (work function ' w ' of the metal), the most loosely bound electron will emerge with maximum kinetic energy, more tightly bound electron will emerge with kinetic energies less than the maximum value.

Einstein's photoelectric equation

$$E_k = h\nu - \omega$$

$$E_k = h\nu - h\nu_0$$

$$E_k = h(\nu - \nu_0)$$

X-rays:

When cathode rays strike on a heavy metal of high melting point. then a very small fraction of its energy converts into a new type of waves, called X-rays.

Properties of X-rays:

- X-rays were discovered by Roentgen.
- X-rays are electromagnetic waves of wavelengths ranging from 0.1 Å to 100 Å and frequencies ranging from 10^{16} Hz to 10^{18} Hz.
- Soft X-rays have greater wavelength and lower frequency.

- Hard X-rays have lower wavelength and higher frequency.
- X-rays are produced by Coolidge tube.
- Molybdenum and tungsten provide suitable targets. These elements have large atomic number and high melting point for the purpose.
- The intensity of X – rays depend on the heating voltage or filament current.

Moseley's Law:

The frequency of X-ray is given by

$$V = a (Z - b)^2$$

where a and b are constants and Z is atomic number of element.

Frequency of X-rays

$$\nu \propto Z^2$$

Wave Nature of Matter:

The wave nature of light shows up in the phenomena of interference, diffraction and polarization. De Broglie proposed that the wavelength λ associated with a particle of momentum p is given as.

$$\lambda = \frac{h}{p} = \frac{h}{mv}$$

Photocell:

- It is an arrangement which converts light energy into electric energy.
- It works on the principle of photoelectric effect.
- It is used in cinematography for the reproduction of sound.

Photoelectric current: Photoelectric current depends on the intensity of incident light and the potential difference applied between the two electrodes.

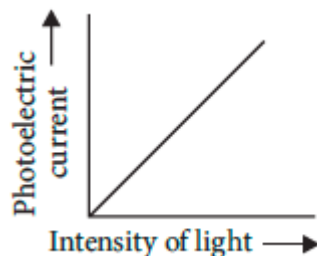

Particle Nature of Light:

Photoelectric effect thus gave evidence to the strange fact that light in interaction with matter behaved as if it was made of quanta or packets of energy, each of energy $h\nu$. A definite value of energy as well as momentum is associated with a particle. This particle was later named photon.

We can summaries the photon picture of electromagnetic radiation as follows:

- In interaction of radiation with matter, radiation behaves as if it is made up of particles called photons.
- Each photon has energy $E (= h\nu)$ and momentum $p \left(= \frac{h\nu}{c} \right)$, and speed c , the speed of light.
- All photons of light of a particular frequency ν , or wavelength λ , have the same energy $E \left(= h\nu = \frac{hc}{\lambda} \right)$ and momentum $p \left(= \frac{h\nu}{c} = \frac{h}{\lambda} \right)$. Photons are electrically neutral and are not deflected by electric and magnetic fields.
- In a photon-particle collision (such as photon-electron collision), the total energy and total momentum are conserved.

Davisson and Germer Experiment:

The wave nature of electrons was first experimentally verified independently by C. J. Davisson and L. H. Germer in 1927 and by G. P. Thomson in 1928 while observing diffraction effects with beams of electrons scattered by crystals. The experimental arrangement is schematically shown in figure.

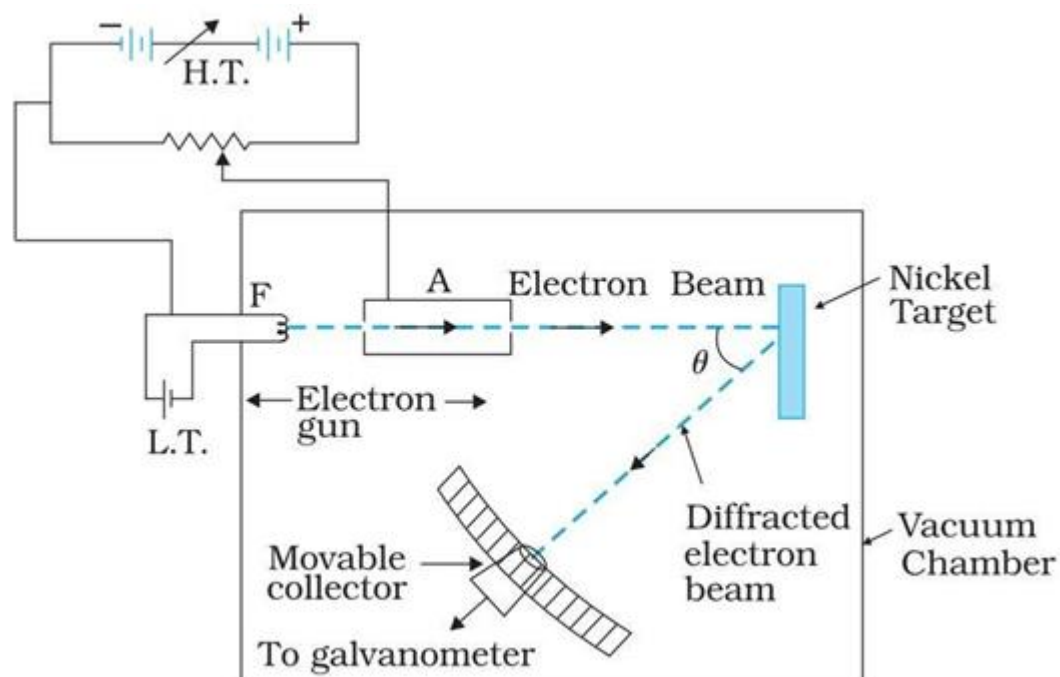

It has an electron gun made up of a tungsten filament F, heated by a low voltage battery and the filament is coated with barium oxide. Emitted electrons from filament are accelerated to a desired velocity by applying required potential/ voltage from a high-voltage power supply. C is a hollow metallic cylinder with a hole along the axis and is kept at negative potential to get a convergent beam of electrons emitted from filament. It acts as a cathode. A is a cylinder with fine hole along its axis acting as an anode.

The cathode and anode form an electron gun by which a fine beam of electrons can be obtained of different velocities by applying different accelerating potentials. N is a nickel crystal cut along cubical diagonal, D is an electron detector which can be rotated on a circular scale and is connected to a sensitive galvanometer which records the current.

Working: From electron gun a fine beam of accelerated electrons is made to fall normally on the surface of nickel crystal. The atoms of the crystal scatter the incident electrons in different directions. The detector detects the intensity of the electron beam scattered direction by rotating the electron detector on circular scale at different positions.

According to de Broglie hypothesis, the wavelength of the wave associated with electron is given by.

$$\lambda = \frac{12.27}{\sqrt{V}} \text{ \AA}$$

Class : 12th Physics
Chapter- 11 : Dual nature of radiation and matter

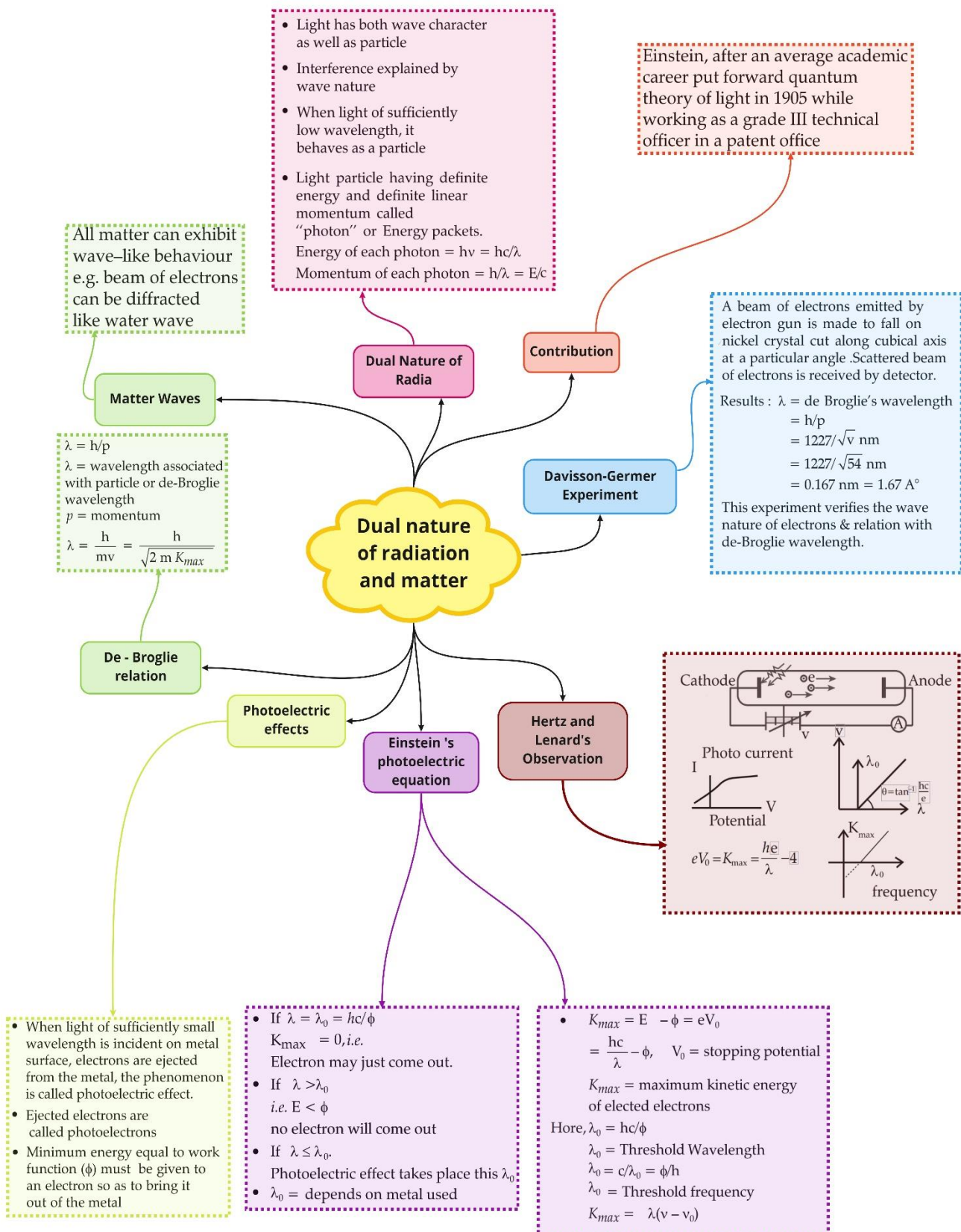

Important Questions

Multiple Choice questions-

Question 1. Photoelectrons are being obtained by irradiating zinc by a radiation of 3100 \AA . In order to increase the kinetic energy of ejected photoelectrons.

- (a) the intensity of radiation should be increased.
- (b) the wave length of radiation should be increased.
- (c) the wavelength of radiation should be decreased.
- (d) both wavelength and intensity of radiation should be increased.

Question 2. The de-Broglie wavelength of an electron moving with a speed of $6.6 \times 10^{15} \text{ ms}^{-1}$ is nearly equal to

- (a) 10^{-11} m
- (b) 10^{-9} m
- (c) 10^{-7} m
- (d) 10^{-5} m

Question 3. An electron accelerated through a potential difference of V volt has a wavelength λ associated with it, Mass of proton is nearly 2000 times that of an electron. In order to have the same λ for proton, it must be accelerated through a potential difference (in volt) of:

- (a) V
- (b) $\sqrt{2000} V$
- (c) $2000V$
- (d) $\frac{V}{2000}$

Question 4. An electron of mass m , when accelerated through a potential difference V , has de-Broglie wavelength λ . The de-Broglie wavelength associated with a proton of mass M and accelerated through the same potential difference will be

- (a) $\lambda \sqrt{\frac{m}{M}}$
- (b) $\lambda \frac{m}{M}$
- (c) $\lambda \sqrt{\frac{M}{m}}$
- (d) $\lambda \sqrt{\frac{m}{m}}$

Question 5. The energy E and momentum p of a photon is given by $E = h\nu$ and $p = \frac{h}{\lambda}$. The velocity of photon will be:

- (a) $\frac{E}{P}$
- (b) $(\frac{E}{P})^2$
- (c) $\sqrt{\frac{E}{P}}$
- (d) $(EP)^3$

Question 6. Ultra-violet radiation of 6.2 eV falls on an aluminium surface having work-function 4.2 eV. The kinetic energy (in J) of the fastest electron emitted is nearly.

- (a) 3×10^{-19}
- (b) 3×10^{-15}
- (c) 3×10^{-17}
- (d) 3×10^{-21}

Question 7. For light of wavelength 5000 Å, the photon energy is nearly 2.5 eV. For X-rays of wavelength 1 Å, the photon energy will be close to:

- (a) 2.5×5000 eV
- (b) $2.5 \div 5000$ eV
- (c) $2.5 \times (5000)^2$ eV
- (d) $2.5 \div (5000)^2$ eV.

Question 8. A photocell is illuminated by a small bright source placed 1 metre away. When the same source of light is placed 2 m away, the electrons emitted per sec. (i.e. saturation current in the photo cell is) are

- (a) $I \propto 2^2$
- (b) $I \propto \frac{1}{4}$
- (c) $I \propto 4$
- (d) $I \propto \frac{1}{2}$

Question 9. Which one of the following graph represent correctly the variation of maximum kinetic energy E_{\max} with the intensity of incident radiations having a constant frequency.

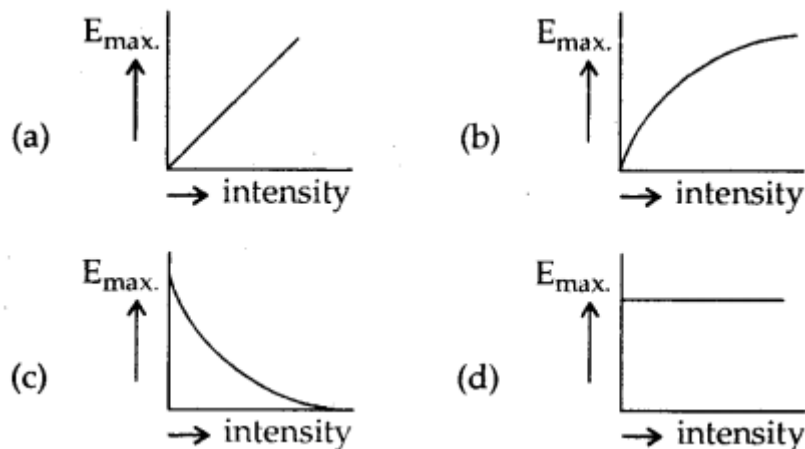

Question 10. The best metal to be used for photoemission is:

- (a) Potassium
- (b) Lithium
- (c) Sodium
- (d) Cesium

Question 11. The threshold frequency for a certain metal is ν_0 . When light of frequency $\nu = 2\nu_0$ is incident on it, the maximum velocity of photo electrons is $4 \times 10^6 \text{ ms}^{-1}$. If the frequency of incident radiation is increased to $5\nu_0$, then the maximum velocity of photo electrons (m/s) is:

- (a) 8×10^5
- (b) 2×10^6
- (c) 2×10^7
- (d) 8×10^6

Question 12. The frequency and the intensity of a beam of light falling on the surface of photoelectric material are increased by a factor of two. This will:

- (a) increase the maximum K.E. of photo-electron as well as photoelectric current by a factor of two.
- (b) increase maximum K.E. of photoelectrons and would increase the photo current by a factor of two.
- (c) increase the maximum K.E. of photo electrons by a factor of two and will not affect photoelectric current.
- (d) No effect on both maximum K.E. and photoelectric current.

Question 13. Which of the following is not the property of photons:

- (a) charge
- (b) rest mass
- (c) energy
- (d) momentum

Question 14. Dynamic mass of photon of wavelength λ is:

- (a) Zero
- (b) $\frac{hc}{\lambda}$
- (c) $\frac{h}{c\lambda}$
- (d) $\frac{h}{2\lambda}$

Question 15. The time required in emitting photo electrons is:

- (a) 10^{-8} s
- (b) 10^{-4} s
- (c) Zero
- (d) 1 sec

Very Short :

1. Calculate the energy associated in eV with a photon of wavelength 4000 \AA
2. Mention one physical process for the release of electrons from the surface of a metal.
3. The maximum kinetic energy of photoelectron is 2.8 eV. What is the value of stopping potential?
4. Calculate the threshold frequency of photon for photoelectric emission from a metal of work function 0.1 eV
5. Ultraviolet light is incident on two photosensitive materials having work function Φ_1 and Φ_2 ($\Phi_1 > \Phi_2$). In which of the case will K.E. of emitted electrons be greater? Why?
6. Show graphically how the stopping potential for a given photosensitive surface varies with the frequency of incident radiations.
7. How does the stopping potential applied to a photocell change if the distance between the light source and the cathode of the cell is doubled?
8. On what factor does the retarding potential of a photocell depend?
9. Electron and proton are moving with same speed, which will have more wavelength?
10. If the maximum kinetic energy of electrons emitted by photocell is 4 eV, what is the stopping potential?

Short Questions :

1. An α -particle and a proton of the same kinetic energy are in turn allowed to pass through a magnetic field B , acting normal to the direction of motion of the particles. Calculate the ratio of radii of the circular paths described by them. (CBSE Delhi 2019)
2. How will the photoelectric current change on decreasing the wavelength of incident radiation for a given photosensitive material?
3. Estimate the ratio of the wavelengths associated with the electron orbiting around the nucleus in the ground and first excited states of a hydrogen atom. (CBSE Delhi 2019C)
4. Show graphically how the stopping potential for a given photosensitive surface varies with the frequency of the incident radiation.
5. The de-Broglie wavelength associated with an electron accelerated through a potential difference V is λ . What will be its wavelength when accelerating potential is increased to $4V$?
6. Plot a graph showing the variation of de Broglie wavelength (λ) associated with a charged particle of mass m , versus $\frac{1}{\sqrt{V}}$ where V is the potential difference through which the particle is accelerated. How does this graph give us information regarding the magnitude of the charge of the particle? (CBSE Delhi 2019)
7. X-rays of wavelength ' λ ' fall on a photosensitive surface, emitting electrons. Assuming that the work function of the surface can be neglected, prove that the de-Broglie wavelength of the electrons emitted will be $\sqrt{\frac{h\lambda}{2mc}}$
8. Explain with the help of Einstein's photoelectric equation any two observed features in the photoelectric effect. cannot be explained by the wave theory. (CBSE Delhi 2019)
9. Why is the wave theory of electromagnetic radiation not able to explain the photoelectric effect? How does the photon picture resolve this problem? (CBSE Delhi 2019)
10. (a) Define the terms,
 - (i) threshold frequency and

(ii) stopping potential in the photoelectric effect.

(b) Plot a graph of photocurrent versus anode potential for radiation of frequency ν and intensities I_1 and I_2 . ($I_1 < I_2$). (CBSE Delhi 2019)

LongAnswersQuestions:

Question 1. What is the photoelectric effect? Write Einstein's photoelectric equation and use it to explain: (a) independence of maximum energy of emitted photoelectrons from the intensity of incident light and (b) existence of a threshold frequency for the emission of photoelectrons.

Question 2. An electron of mass m and charge q is accelerated from rest through a potential difference of V . Obtain the expression for the de-Broglie wavelength associated with it. If electrons and protons are moving with the same kinetic energy, which one of them will have a larger de-Broglie wavelength associated with it? Give reason.

Question 3. Sketch the graphs showing the variation of stopping potential with the frequency of incident radiations for two photosensitive materials A and B having threshold frequencies $\nu_0 > \nu'_0$ respectively.

- Which of the two metals A or B has a higher work function?
- What information do you get from the slope of the graphs?
- What does the value of the intercept of graph 'A' on the potential axis represent?

Question 4. When a given photosensitive material is irradiated with light of frequency ν , the maximum speed of the emitted photoelectrons equals V_{\max} . The graph shown in the figure gives a plot of V_{\max}^2 varying with frequency ν .

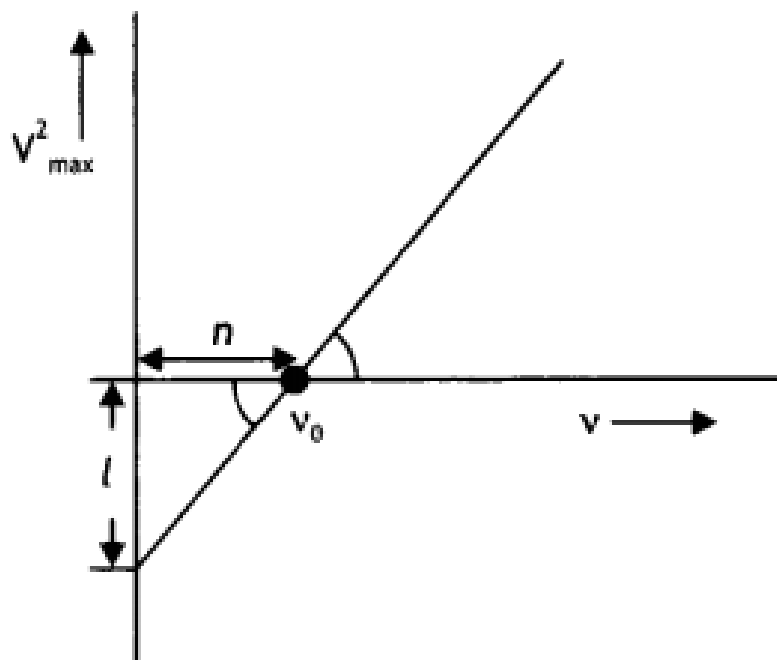

Obtain an expression for:

- Planck's constant, and
- The work function of the given photosensitive material in terms of the parameters T , ' n ' and the mass ' m ' of the electron.
- How is threshold frequency determined from the plot? (CBSE AI 2019)

Question 5. X-rays fall on a photosensitive surface to cause photoelectric emission. Assuming that the work function of the surface can be neglected, find the relation between the de-Broglie wavelength (λ) of the electrons emitted to the energy (E_v) of the incident photons. Draw the nature of the graph for λ as a function of E_v . (CBSE Delhi 2014C)

Question 6. Light of intensity ' I ' and frequency ' ν ' is incident on a photosensitive surface and causes photoelectric emission. What will be the effect on anode current when:

- the intensity of light is gradually increased,
- the frequency of incident radiation is increased and
- the anode potential is increased?

In each case, all other factors remain the same. Explain giving justification in each case. (CBSE AI 2015)

Question 7. The graphs, drawn here, are for the phenomenon of the photoelectric

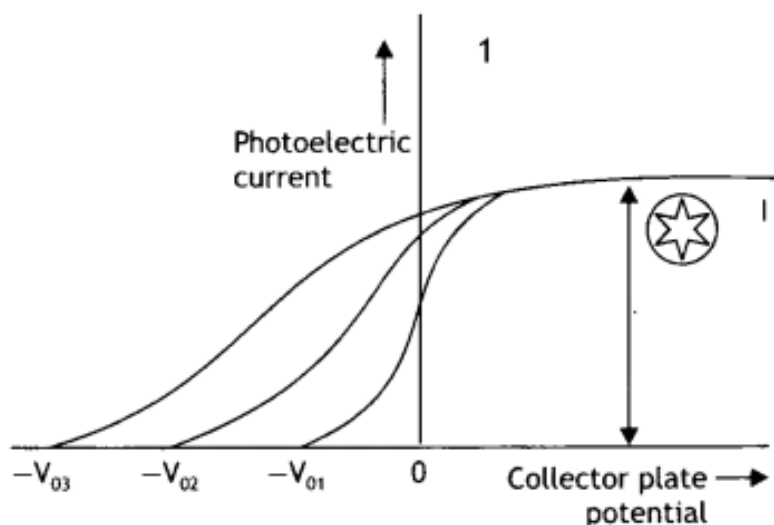

effect.

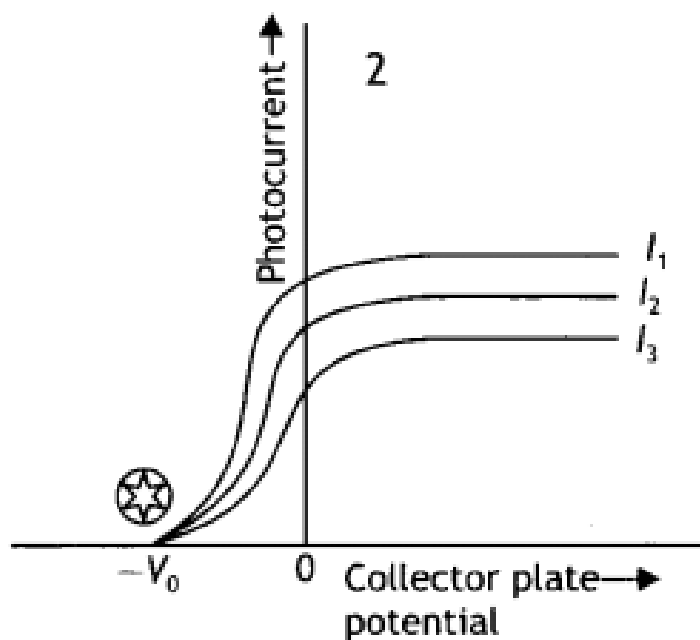

(a) Identify which of the two characteristics (intensity/frequency) of incident light is being kept constant in each case.

(b) Name the quantity, corresponding to the \odot mark, in each case.

(c) Justify the existence of a 'threshold frequency' for a given photosensitive surface. (CBSE Delhi 2016C)

Question 8. Draw a graph showing the variation of de-Broglie wavelength λ of a particle of charge q and mass, with the accelerating potential V . An alpha particle and a proton have the same de-Broglie wavelength equal to 1 \AA . Explain with calculations, which of the two has more kinetic energy. (CBSE Delhi 2017C)

Assertion and Reason Questions-

1. For question two statements are given-one labelled Assertion (A) and the other labelled Reason (R). Select the correct answer to these questions from the codes (a), (b), (c) and (d) as given below.

- a) Both A and R are true and R is the correct explanation of A.
- b) Both A and R are true but R is NOT the correct explanation of A.
- c) A is true but R is false.
- d) A is false and R is also false.

Assertion (A): Photoelectric effect demonstrates the wave nature of light.

Reason (R): The number of photoelectrons is proportional to the frequency of light.

2. For question two statements are given-one labelled Assertion (A) and the other labelled Reason (R). Select the correct answer to these questions from the codes (a), (b), (c) and (d) as given below.

- a) Both A and R are true and R is the correct explanation of A.
- b) Both A and R are true but R is NOT the correct explanation of A.
- c) A is true but R is false.
- d) A is false and R is also false.

Assertion (A): On increasing the frequency of light, larger number of photoelectrons are emitted.

Reason (R): The number of electrons emitted is directly proportional to the intensity of incident light.

Case Study Questions-

1. To study photoelectric effect, an emitting electrode C of a photosensitive material is kept at negative potential and collecting electrode A is kept at positive potential in an evacuated tube. When light of sufficiently high frequency falls on emitting electrode, photoelectrons are emitted which travel directly to collecting electrode and hence an electric current called photoelectric current starts flowing in the circuit, which is directly proportional to the number of photoelectrons emitted by emitting electrode C.

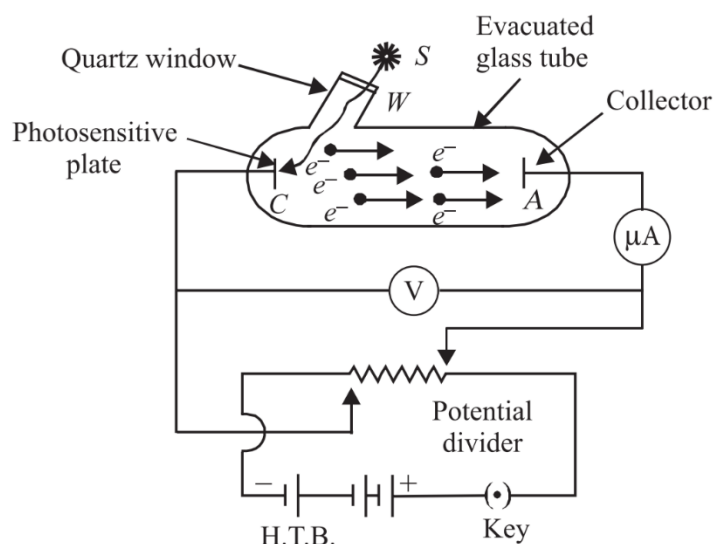

While demonstrating the existence of electromagnetic waves, Hertz found that high voltage sparks passed across the metal electrodes of the detector loop more easily when the cathode was illuminated by ultraviolet light from an arc lamp. The ultraviolet light falling on the metal surface caused the emission of negatively charged particles, which are now known to be electrons, into the surrounding space and hence enhanced the high voltage sparks.

(i) Cathode rays were discovered by:

- Maxwell Clerk James.
- Heinrich Hertz.
- William Crookes.
- J. J. Thomson.

(ii) Cathode rays consists of:

- Photons
- Electrons
- Pistons
- α -particles

(iii) Who discovered the charge on an electron for the first time?

- Millikan
- Thomson
- Kelvin
- Coulomb

(iv) The dual nature of light is exhibited by:

- a) Diffraction and photoelectric effect.
 - b) Photoelectric effect.
 - c) Refraction and interference.
 - d) Diffraction and reflection.
- (v) In the phenomenon of electric discharge through gases at low pressure, the coloured glow in the tube appears as a result of:
- a) Collisions between the charged particles emitted from the cathode and the atoms of the gas.
 - b) Collision between different electrons of the atoms of the gas.
 - c) Excitation of electrons in the atoms.
 - d) Collision between the atoms of the gas.

2. Photoelectric effect is the phenomenon of emission of electrons from a metal surface, when radiations of suitable frequency fall on them. The emitted electrons are called photoelectrons and the current so produced is called photoelectric current.

- (i) With the increase of intensity of incident radiations on photoelectrons emitted by a photo tube, the number of photoelectrons emitted per unit time is:
- a) Increases.
 - b) Decreases.
 - c) Remains same.
 - d) None of these.
- (ii) It is observed that photoelectron emission stops at a certain time t after the light source is switched on. The stopping potential (V) can be represented as:
- a) $2(K_{E_{\max}}/e)$
 - b) $(K_{E_{\max}}/e)$
 - c) $(K_{E_{\max}}/3e)$
 - d) $(K_{E_{\max}}/2e)$
- (iii) A point source of light of power 3.2×10^{-3} W emits monoenergetic photons of energy 5.0eV and work function 3.0eV. The efficiency of photoelectron emission is 1 for every 10^6 incident photons. Assume that photoelectrons are instantaneously swept away after emission. The maximum kinetic energy of photon is:
- a) 4eV
 - b) 5eV
 - c) 2eV

- d) Zero
- (iv) Which of the following device is the application of Photoelectric effect?
- Light emitting diode.
 - Diode.
 - Photocell.
 - Transistor.
- (v) If the frequency of incident light falling on a photosensitive metal is doubled, the kinetic energy of the emitted photoelectron is:
- Unchanged.
 - Halved.
 - Doubled.
 - More than twice its initial value.

Multiple Choice Question's Answers-

1. Answer: (c) the wavelength of radiation should be decreased.

2. Answer: (b) 10^{-9} m

3. Answer: (d) $\frac{V}{2000}$

4. Answer:

$$(a) \lambda \sqrt{\frac{m}{M}}$$

5. Answer: (a) $\frac{E}{P}$

6. Answer: (a) 3×10^{-19}

7. Answer: (a) 2.5×5000 eV

8. Answer: (b) $I \times \frac{1}{4}$

9. Answer: (d)

10. Answer: (d) Cesium

11. Answer: (d) 8×10^6

12. Answer: (b) increase maximum K.E. of photoelectrons and would increase the photo current by a factor of two.

13. Answer: (a) & (b)

14. Answer: (c) $\frac{h}{c\lambda}$

15. Answer: (c) Zero

Very Short Answers:

1. Ans: Given the wavelength of given photon is

$$\lambda = 4000 \overset{\circ}{\text{A}} = 4 \times 10^{-7} \text{ m}$$

Hence the energy associated is

$$E = \frac{hc}{\lambda} = \frac{6.6 \times 10^{-34} \times 3 \times 10^8}{4000 \times 10^{-10}}$$

$$E = 4.95 \times 10^{-19} \text{ J}$$

$$E = \frac{4.95 \times 10^{-19} \text{ J}}{1.6 \times 10^{-19}} \text{ eV} = 3.09 \text{ eV}$$

2. Photoelectric emission.

The phenomenon in which the electrons from the surface of a metal are given energy in form of electromagnetic waves and they are ejected out, this phenomenon is called the photoelectric emission.

3. Given an electron that is moving with a kinetic energy. For it to be not ejected, it has to be held back using a stopping potential

V_0

. The relation between the two is:

$$KE = eV_o = 2.8eV$$

$$\Rightarrow V_o = 2.8V$$

4. Given is the work function

$$0.1 eV$$

$$\phi_o = h\nu_0$$

$$\Rightarrow \nu_0 = \frac{\phi_o}{h} = \frac{0.1eV}{6.6 \times 10^{-34} Js}$$

$$\Rightarrow \nu_0 = \frac{0.1 \times 1.6 \times 10^{-19} J}{6.6 \times 10^{-34} Js} = 2.4 \times 10^{14} Hz$$

And hence the threshold frequency is $2.4 \times 10^{14} Hz$.

5. According to the energy balance equation of the photoelectric effect $h\nu = \Phi_o + K.E$

If $\Phi_1 > \Phi_2$ thus K.E. will be more for second surface whose work function is less.

6. Suppose

ν_o is the threshold of frequency or cut off frequency;

V_o is the corresponding stopping potential

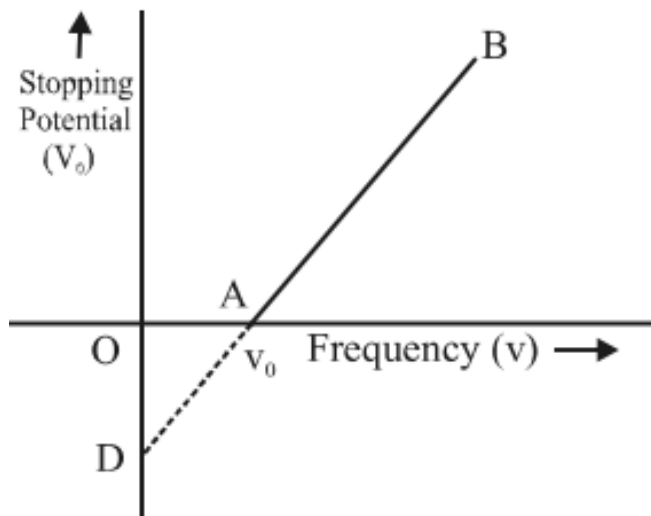

7. Intensity of light drops quadratically with distance. However, the stopping

potential does not depend on the intensity of the light. Hence it is independent of distance as well.

8. The retarding photocell depends upon the frequency of the incident light.
9. Since the wavelength is inversely proportional to the square root of the mass of the body, $\lambda \propto \frac{1}{\sqrt{m}}$. So, electrons being lighter will have more wavelengths.
10. The stopping potential is 4 V.

Short Answers :

1. Given $q_\alpha = 2e$, $q_p = e$, $K_\alpha = K_p$, $m_\alpha = 4m_p$, $r_\alpha/r_p = ?$

Using the expression

$$r = \frac{\sqrt{2mK}}{qB} \text{ we have}$$

$$\frac{r_\alpha}{r_p} = \left(\sqrt{\frac{m_\alpha}{m_p}} \times \frac{q_p}{q_\alpha} \right) = \sqrt{\frac{4m_p}{m_p}} \times \frac{e}{2e} = 1$$

2. Photoelectric current is independent of the wavelength of the incident radiation. Therefore there will be no change in the photoelectric current.
3. Since De Brogue's hypothesis is related to

Bohr's atomic model as

$$n\lambda = 2\pi r$$

Since $r \propto n^2$

$$\therefore r = a_0 n^2$$

$$\therefore n\lambda = 2\pi a_0 n^2$$

$$\therefore \lambda = 2\pi a_0 n$$

$$\frac{\lambda_1}{\lambda_2} = \frac{2\pi a_0 1}{2\pi a_0 2} = \frac{1}{2}$$

4. The required graph is as shown

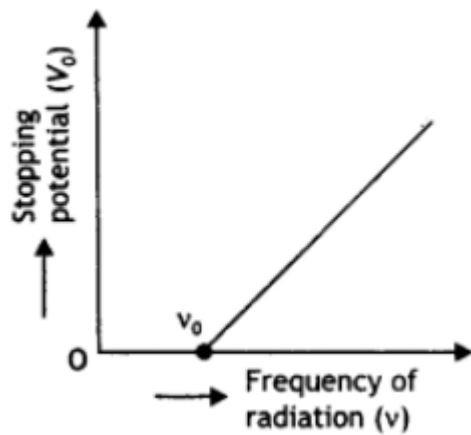

5. The de-Broglie wavelength is inversely proportional to the square root of potential, therefore =

$$\frac{\lambda_2}{\lambda_1} = \frac{\sqrt{V}}{\sqrt{4V}} = \frac{1}{2} . \text{ Thus wavelength}$$

wilt become half of its previous value.

6. The plot is as shown.

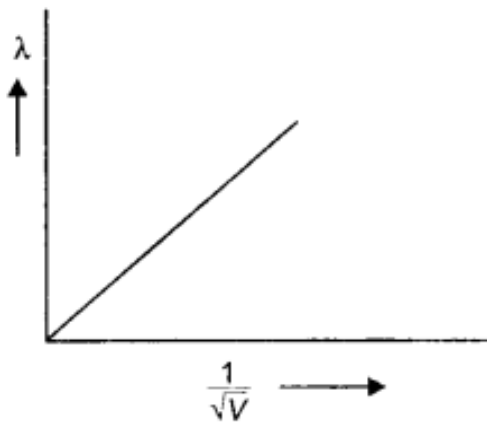

We know that $\lambda = \frac{h}{\sqrt{2mE}} = \frac{h}{\sqrt{2mqV}}$

Now $\frac{\lambda}{1/\sqrt{V}} = \frac{h}{\sqrt{2mq}} = \text{slope of the graph}$

Or $q = \frac{h^2}{2m(\text{slope})^2}$

7. The energy possessed by X-rays of wavelength λ is given by $E=hc / \lambda$.

Consider an electron of mass charge e to be accelerated the potential difference of V volts the velocity gained by it.

Then kinetic energy of electron is

$$E = \frac{1}{2}mv^2 = eV$$

or

$$v = \sqrt{\frac{2eV}{m}} = \sqrt{\frac{2E}{m}}$$

If λ is the de-Broglie wavelength associated with an electron, then

$$\lambda = \frac{h}{mv} = \frac{h}{m\sqrt{\frac{2eV}{m}}} = \frac{h}{\sqrt{2meV}} = \frac{h}{\sqrt{2mE}}$$

Substituting for e , we have

$$\lambda = \frac{h}{\sqrt{2mE}} = \frac{h}{\sqrt{2mhc / \lambda}} = \sqrt{\frac{h\lambda}{2mc}}$$

8. According to Einstein's equation, we have

$$\frac{1}{2}mv_{\max}^2 = h(\nu - \nu_0)$$

Two features

(a) Maximum energy is directly proportional to the frequency

(b) Existence of threshold frequency Explanation of two features:

1. The energy of the photon is directly proportional to the frequency
2. No photoelectric emission is possible if $h\nu < h\nu_0$.

9. According to the wave theory, the more intense a beam, more is the kinetic energy it will impart to the photoelectron. This does not agree with the experimental observations (max K.E. of the emitted photoelectron is independent of intensity) on the photoelectric effect. Also according to the wave theory photoemission can occur at all frequencies.

The photon picture resolves this problem by saying that light in interaction with matter behaves as if it is made of quanta or packets of energy, each of energy $h\nu$. This picture enables us to get a correct explanation of all the observed experimental features of the photoelectric effect.

10.(a) Threshold frequency: It is the frequency of the incident radiation below which photoelectric effect does not take place.

Stopping potential: It is the minimum negative (retarding) potential, given to the anode (collector plate) for which the photocurrent stops or becomes zero.

(b) The plot is as shown.

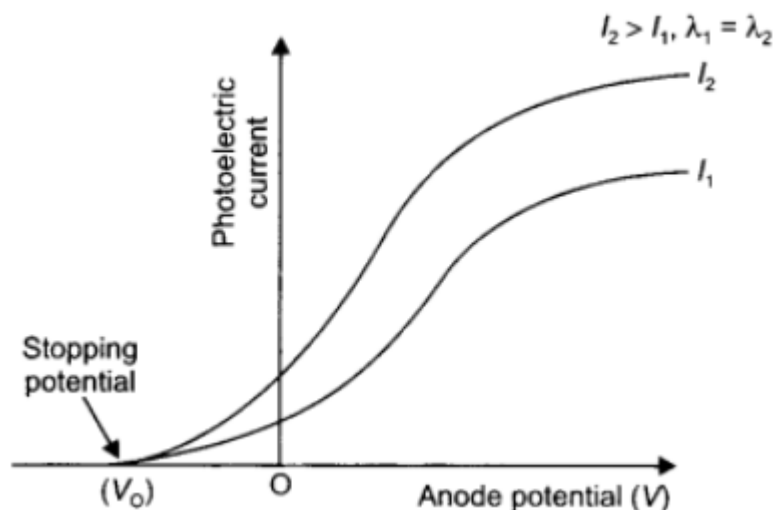

LongAnswers:

1. Answer: The ejection of photoelectrons from a metal surface when light of suitable frequency is incident on it is called photoelectric effect.

Einstein's equation of photoelectric effect is $\frac{1}{2}mv^2 = h\nu - \omega_0$

(a) In accordance with Einstein's equation, the kinetic energy of the photoelectrons is independent of the intensity of the incident radiation.

(b) In accordance with Einstein's equation, the kinetic energy will be positive and hence photoelectrons will be ejected if $\nu > \nu_0$. Thus below a certain frequency called threshold frequency, photoelectrons are not ejected from a metal surface (if $\nu < \nu_0$).

2. Answer: Consider an electron of mass m and charge e to be accelerated through a potential difference of V volts. Let v be the velocity gained by it. Then kinetic energy of the electron is

$$E = \frac{1}{2}mv^2 = eV$$

$$\text{or } v = \sqrt{\frac{2eV}{m}} = \sqrt{\frac{2E}{m}}$$

If λ is the de-Broglie wavelength associated with an electron, then

$$\lambda = \frac{h}{mv} = \frac{h}{m\sqrt{\frac{2ev}{m}}} = \frac{h}{\sqrt{2meV}} = \frac{h}{\sqrt{2mE}}$$

Since de-Broglie wavelength is inversely proportional to the square root of mass, the lesser the mass, the more is the de-Broglie wavelength. Since the mass of an electron is lesser than that of the proton, the electron has a greater de-Broglie wavelength than a proton.

3. Answer: The graphs are as shown below.

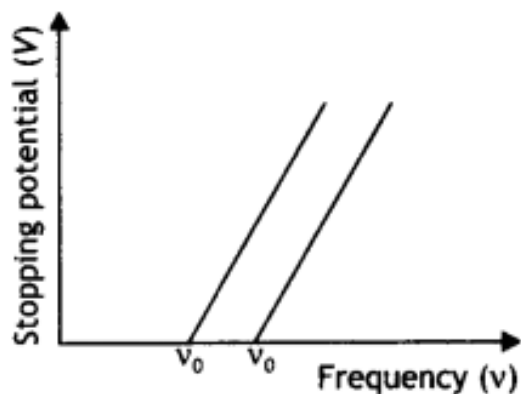

- (a) The work function is directly proportional to the threshold frequency. The threshold frequency of metal A is greater than that of metal B; therefore A has a greater work function than B.
- (b) The slope of the graphs gives the value of Planck's constant.
- (c) The intercept on the potential axis is negative ($-W_0/e$) w.r.t. stopping potential, i.e. Work function = $e \times$ magnitude of the intercept on the potential axis. We may infer it to give the voltage which, when applied with opposite polarity to the stopping voltage, will just pull out electrons from the metallic atom's outermost orbit.

4. Answer: (a) By Einstein's photoelectric equation we have

$$K_{\max} = \frac{1}{2}mv_{\max}^2 = h\nu - \phi_0$$

$$\text{or } v_{\max}^2 = \left(\frac{2h}{m}\right)\nu - \frac{2\phi_0}{m}$$

$$\text{Slope of the graph} = \frac{2h}{m} = \frac{c}{n}$$

(b)

The intercept on V_{\max}^2 axis is $= \frac{2\phi_0}{m} = l$

Therefore, work function $\phi_0 = \frac{ml}{2}$

(c) The threshold frequency is the intercept on the ν axis i.e. $\nu_0 = n$

5. Answer:

Consider an electron of mass m and charge e to be accelerated through a potential difference of V volt. Let v be the velocity gained by it. Then kinetic energy of the electron is

$$E_v = \frac{1}{2}mv^2 \quad \text{or} \quad v = \sqrt{\frac{2E_v}{m}}$$

If λ is the de-Broglie wavelength associated with an electron, then

$$\lambda = \frac{h}{mv} = \frac{h}{\sqrt{2mE_v}}$$

The nature of the graph is as shown.



6. Answer:(a) Anode current will increase with the increase of intensity as the more the intensity of light, the more is the number of photons and hence more number

of photoelectrons are ejected.

(b) No effect as the frequency of light affects the maximum K.E. of the emitted photoelectrons.

(c) Anode current will increase with anode potential as more anode potential will accelerate the more electrons till it attains a saturation value and gets them collected at the anode at a faster rate.

7. Answer: (a) Graph 1: Intensity, Graph 2: Frequency

(b) Graph 1: Saturation current, Graph 2: stopping potential

(c) The electrons require minimum energy to set themselves free. This is called the work function. As the energy of the photon depends upon its frequency, the photons must possess a minimum frequency so that their energy becomes equal to or greater than the work function. This is called threshold frequency and is given by

$$\nu_0 = \frac{\omega_0}{h}$$

8. Answer: The graph is as shown.

The de-Broglie wavelength of a particle is given by the expression $\lambda = \frac{h}{\sqrt{2mqV}}$

Since the alpha particle and the proton have the same de- Broglie wavelength, we have

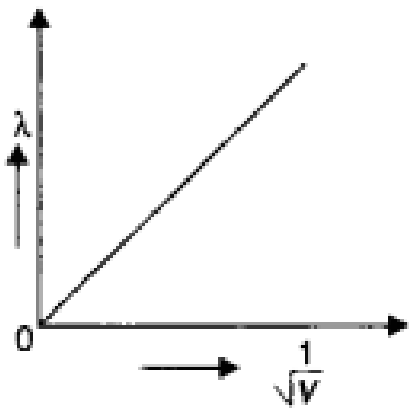

$$\frac{h}{\sqrt{2m_a E_a}} = \frac{h}{\sqrt{2m_p E_p}}$$

Therefore proton has a greater value of de-Broglie wavelength.

Now kinetic energy is given by the expression

$$\frac{E_a}{E_p} = \frac{m_p}{m_a} = \frac{m}{4m} = \frac{1}{4}$$

Thus proton has more kinetic energy.

Assertion and Reason Answers-

1. (d) A is false and R is also false.

Explanation:

Photoelectric effect can be explained on the basis of quantum theory or particle nature of light where wave nature of light fails to explain the photoelectric effect. The number of photoelectrons is proportional to the intensity of incident light.

$I = nh\nu$ where n is the number of photons emitted/ absorbed per unit area per second. n and $h\nu$ are independent factors.

2. (d) A is false and R is also false.

Explanation:

The maximum kinetic energy of the photoelectrons varies linearly with the frequency of incident radiation, but is independent of its intensity. The number of photoelectrons emitted per second is directly proportional to the intensity of incident radiation.

Case Study Answers-

1. Answer :

- (i) (c) William Crookes.
- (ii) (b) Electrons
- (iii)(a) Millikan
- (iv)(a) Diffraction and photoelectric effect.
- (v) (c) Excitation of electrons in the atoms.

Explanation:

In discharge tube, collision between charged particles emitted from cathode and atoms of the gas results to colorless glow in the tube.

2. Answer :

(i) (a) Increases.

Explanation:

With the increase of intensity of the incident radiation the number of photoelectrons emitted per unit time increases.

(ii) (b) (KE_{\max}/e)

Explanation:

As $eV = KE_{\max}$

$$\therefore V = \left(\frac{KE_{\max}}{e} \right)$$

(iii) (c) 2eV

Explanation:

From Einstein's photoelectric equation,

$$KE_{\max} = h\nu - \phi = (5 - 3) = 2eV$$

(iv) (c) Photocell.

Explanation:

A photocell is a technological application of the photoelectric effect.

(v) (d) More than twice its initial value.

Explanation:

According to Einstein's photoelectric equation, the kinetic energy of the emitted photoelectron is

$$K = h\nu - \phi_0$$

where ν is the frequency of incident radiation and ϕ_0 is a work function of the metal.

If the frequency of incident radiation is doubled, then

$$K' = 2h\nu - \phi_0 = 2(h\nu - \phi_0) + \phi_0$$

$$K' > 2K$$



C V RAMAN
P U C O L L E G E
I N D I

CHAPTER 12: ATOMS

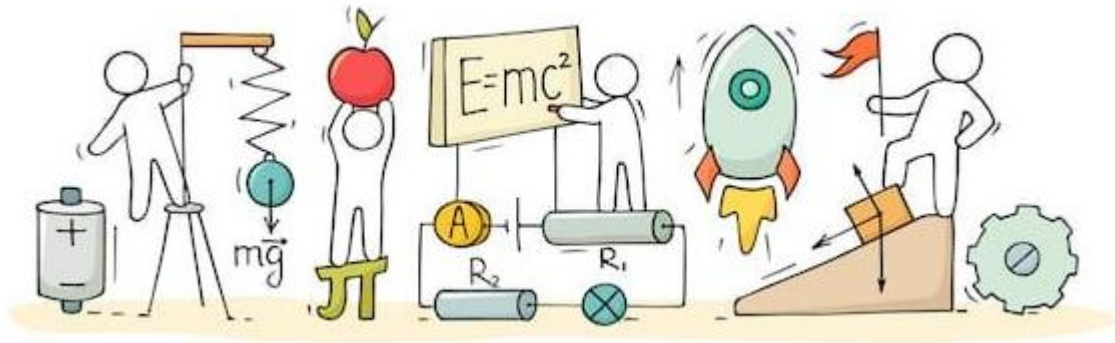

ATOMS

Atoms:

Atoms are made up of the same amount of negative and positive charges. In Thomson's model, atoms were described as a spherical cloud of positive charges with embedded electrons. In Rutherford's model, one tiny nucleus bears most of the mass of the atom along with its positive charges and the electrons revolve around it.

Dalton's Atomic Theory:

All elements are consisting of very small invisible particles, called atoms. Atoms of same element are exactly same, and atoms of different element are different.

Thomson's Atomic Model:

Every atom is uniformly positive charged sphere of radius of the order of 10^{-10} m, in which entire mass is uniformly distributed and negative charged electrons are embedded randomly.

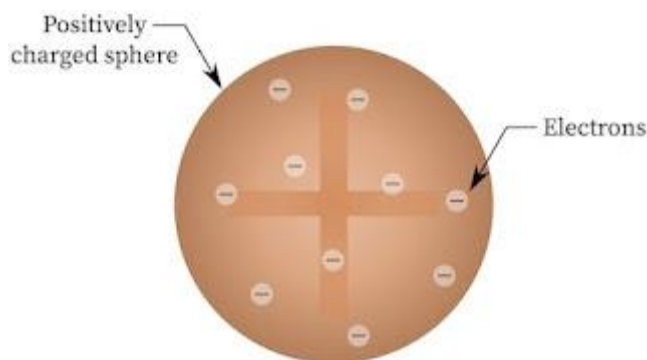

Limitations of Thomson's Atomic Model:

- It could not explain the origin of spectral series of hydrogen and other atoms.
- It could not explain large angle scattering of α – particles.

Alpha-Particle Scattering:

In 1911, Rutherford, along with his assistants, H. Geiger and E. Marsden, performed the Alpha Particle scattering experiment, which led to the birth of the 'nuclear model of an atom'.

They took a thin gold foil having a thickness of 2.1×10^{-7} m and placed it in the center of a rotatable detector made of zinc sulfide and a microscope. Then, they directed a

beam of 5.5MeV alpha particles emitted from a radioactive source at the foil. Lead bricks collimated these alpha particles as they passed through them.

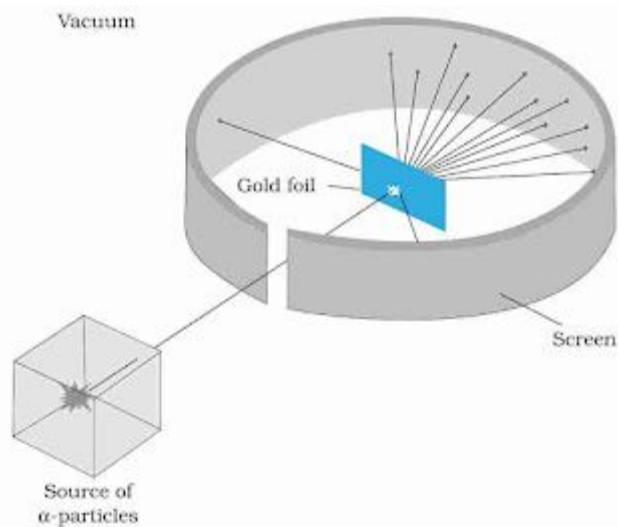

After hitting the foil, the scattering of these alpha particles could be studied by the brief flashes on the screen. Rutherford and his team expected to learn more about the structure of the atom from the results of this experiment.

Observations:

Here is what they found:

- Most of the alpha particles passed through the foil without suffering any collisions
- Around 0.14% of the incident alpha particles scattered by more than 10° .
- Around 1 in 8000 alpha particles deflected by more than 90° .

Rutherford's Nuclear Model:

In 1912, Rutherford proposed his nuclear model of the atom. It is also known as Rutherford's planetary model of atom.

Salient features of Rutherford's atom model are as follows:

- Every atom consists of a tiny central core, named nucleus, in which the entire positive charge and almost whole mass of the atom are concentrated. The size of nucleus is typically 10^{-4} times the size of an atom.
- Most of an atom is empty space.
- In free space around the nucleus, electrons would be moving in orbits just as the planets do around the sun. The centripetal force needed for orbital motion of electrons is provided by electrostatic attractive force.

by electron due to positively charged nucleus.

- An atom as a whole is electrically neutral. Thus, total positive charge of nucleus is exactly equal to total negative charge of all the electrons orbiting in an atom.

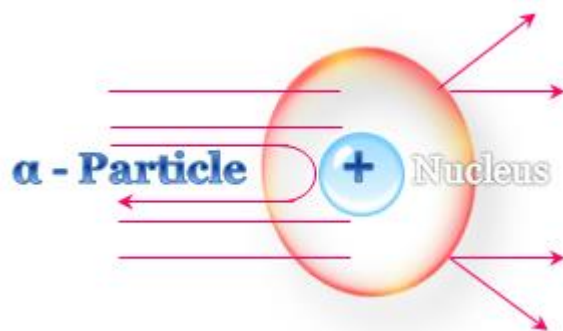

Impact Parameter:

The perpendicular distance of the velocity vector of α -particle from the central line of the nucleus, when the particle is far away from the nucleus is called impact parameter.

$$\text{Impact parameter } b = \frac{1}{4\pi\epsilon_0} \cdot \frac{Ze^2 \cot\left(\frac{\theta}{2}\right)}{E_k}$$

where, Z = atomic number of the nucleus, E_k = kinetic energy of the α -particle and θ = angle of scattering.

Bohr Model of the Hydrogen Atom:

It was Niels Bohr (1885-1962) who used the concept of quantized energy, and explained the model of a hydrogen atom in 1913. Bohr combined classical and early quantum concepts and proposed a theory in the form of three postulates.

These postulates are:

- **Postulate I:** An electron in an atom could revolve in certain stable orbits without emitting radiant energy. Each atom has certain definite stable orbits. Electrons can exist in these orbits. Each possible orbit has definite total energy. These stable orbits are called the stationary states of the atom.
- **Postulate II:** An electron can revolve around the nucleus in an atom only in those stable orbits whose angular momentum is the integral multiple of $\frac{h}{2\pi}$ (where h is Planck's constant). Therefore, angular momentum (L) of the orbiting electron is quantised.

$$mvr = \frac{nh}{2\pi} \text{ where, } n = 1, 2, 3, \dots$$

- **Postulate III:** An electron can make a transition from its stable orbit to another lower stable orbit. While doing so, a photon is emitted whose energy is equal to the energy difference between the initial and final states. Therefore, the energy of photon is given by,

$$hu = E_i - E_f$$

where E_i and E_f are the energies of the initial and final states.

Failure of Bohr's Model:

- This model is applicable only to hydrogen-like atoms and fails in case of higher atoms.
- It could not explain the fine structure of the spectral lines in the spectrum of hydrogen atom.

Ground State and Excited States:

The lowest energy level of an atom is called the "ground state" and higher levels are called "excited states". The H-atom has lowest energy in the state for the principal quantum number $n = 1$. and all other states (i.e, for $n = 2, 3, 4...$) are excited states. Thus $E_2, E_3, E_4 ...$ are called the first, the second, the third ...excited states respectively.

Hydrogen Spectrum Series:

Each element emits a spectrum of radiation, which is characteristic of the element itself. The spectrum consists of a set of isolated parallel lines and is called the line spectrum.

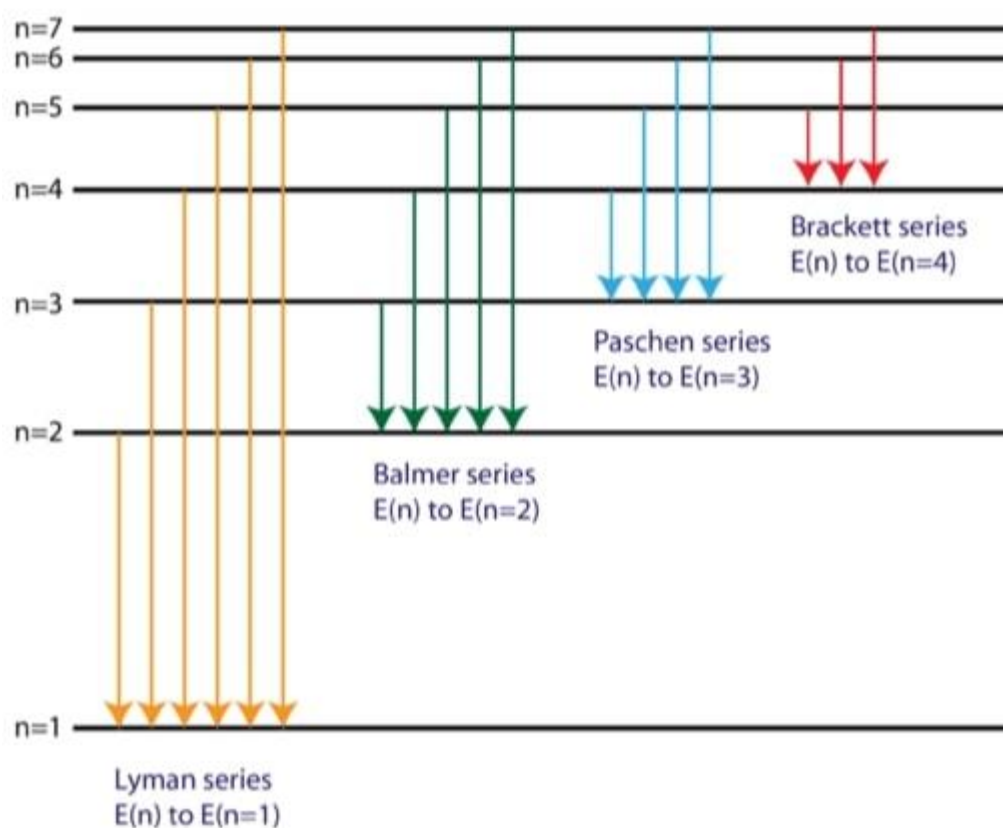

There are four visible spectral lines corresponded to transitions from higher energy levels down to the second energy level ($n = 2$). This is called the **Balmer series**. Transitions ending in the ground state ($n = 1$) are called the **Lyman series**, but the energies released are so large that the spectral lines are all in the ultraviolet region of the spectrum. The transitions called the **Paschen series** and the **Brackett series** both result in spectral lines in the infrared region because the energies are too small.

Wave Model:

It is based on wave mechanics. Quantum numbers are the numbers required to completely specify the state of the electrons.

In the presence of strong magnetic field, the four-quantum number are:

- Principal quantum number (n) can have value $1, 2, \dots, \infty$
- Orbital angular momentum quantum number l can have value $0, 1, 2, \dots, (n - 1)$.
- Magnetic quantum number (m_l) which can have values $-l$ to l .
- Magnetic spin angular momentum quantum number (m_s) which can have only two values $\pm \frac{1}{2}$.

De Broglie's Hypothesis:

This states that the wavelength of electrons is $\lambda = \frac{h}{mv}$ and the whole number of wavelengths is equal to the orbits circumference the main orbit corresponding to the circular standing waves.

Binding Energy:

Binding energy of a system is defined as the minimum energy needed to separate its constituents to large distances. This may also be defined as the energy released when its constituents are brought from infinity to form the system. The binding energy of H-atom in ground state is 13.6 eV which is the same as its ionization energy.

Ionization Energy and Ionization Potential:

The minimum energy needed to ionize an atom is called “ionization energy”. The potential difference through which an electron should be accelerated to acquire this much energy is called “ionization potential”. Hence, ionization energy of H-atom in ground state is 13.6 eV and ionization potential is 13.6 V.

de-Broglie’s Explanation of Bohr’s Second Postulate:

de-Broglie explained second postulate of Bohr’s atomic model by assuming an electron to a particle wave. Therefore, it should form standing waves under resonance condition.

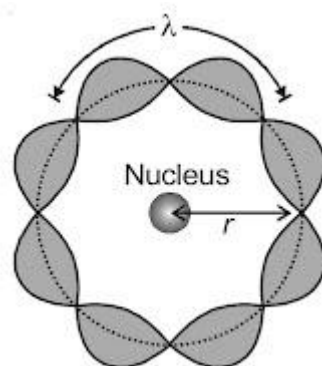

According to de-Broglie, for an electron moving in n th circular orbit of radius r ,

$$2\pi r = n\lambda \quad n = 1, 2, 3 \dots$$

i.e., circumference of orbit should be integral multiple of de-Broglie wavelength of electron moving in n th orbit. As we know that de-Broglie wavelength,

$$\lambda = \frac{h}{mv}$$

$$2\pi r = \frac{nh}{mv}$$

$$mvr = \frac{nh}{2\pi}$$

Class : 12th Physics
Chapter : 12 Atoms

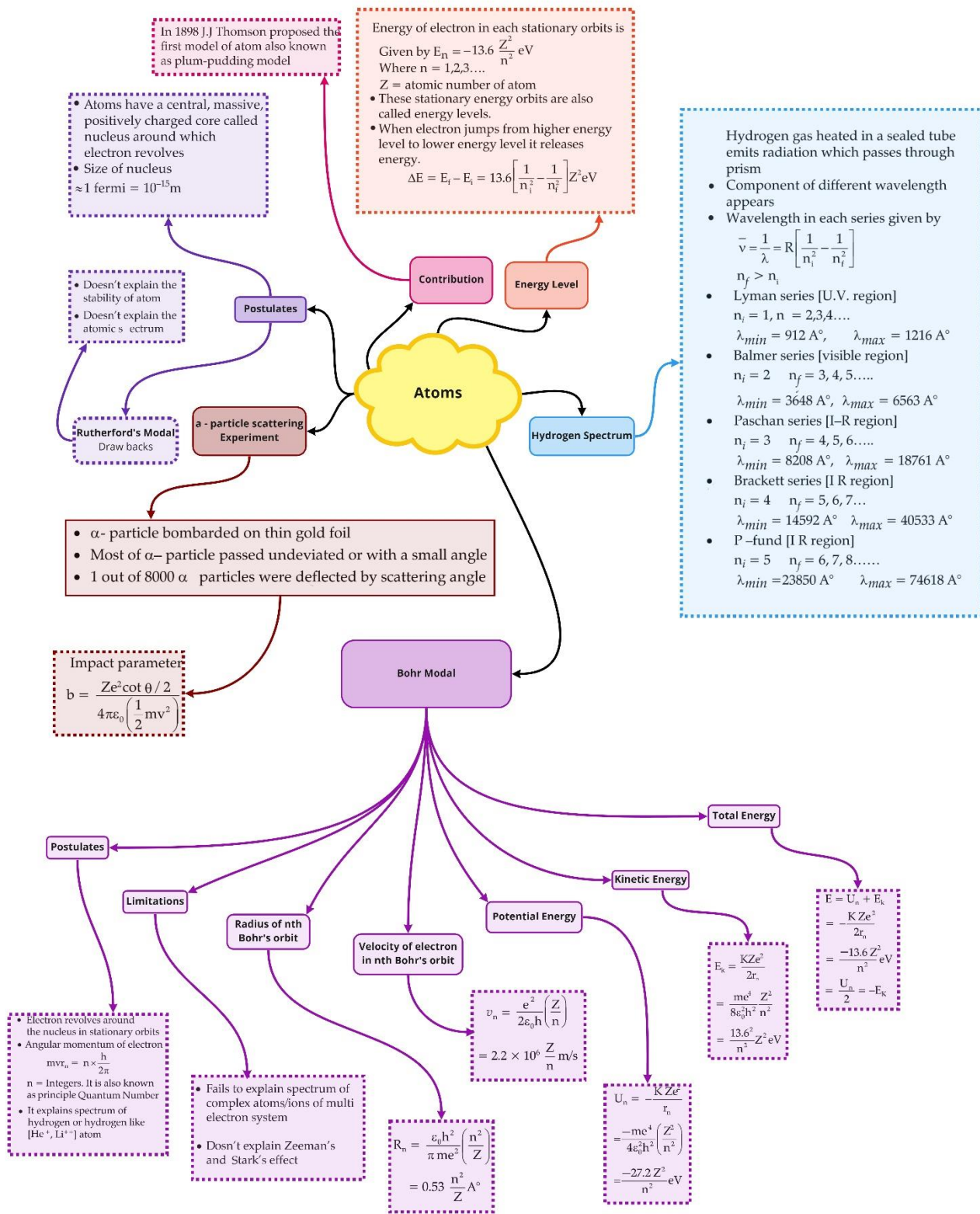

Important Questions

Multiple Choice questions-

Question 1. The simple Bohr model cannot be directly applied to calculate the energy levels of an atom with many electrons. This is because

- (a) of the electrons not being subject to a central force.
- (b) of the electrons colliding with each other
- (c) of screening effects
- (d) the force between the nucleus and an electron will no longer be given by Coulomb's law.

Question 2. A set of atoms in an excited state decay.

- (a) in general, to any of the states with lower energy.
- (b) into a lower state only when excited by an external electric field.
- (c) all together simultaneously into a lower state.
- (d) to emit photons only when they collide.

Question 3. The ground state energy of hydrogen atom is -13.6 eV. The kinetic and potential energies of the electron in this state are

- (a) -13.6 eV, 27.2 eV
- (b) 13.6 eV, -13.6 eV
- (c) 13.6 eV, -27.2 eV
- (d) 27.2 eV, -27.2 eV

Question 4. If the series limit frequency of the Lyman series is ν_L , then the series limit frequency of the Pfund series is:

- (a) $16 \nu_L$
- (b) $\nu_L/16$
- (c) $\nu_L/25$
- (d) $25 \nu_L$

Question 5. The ratio of kinetic energy to the total energy of an electron in a Bohr orbit of the hydrogen atom is:

- (a) $1 : 1$
- (b) $1 : -1$
- (c) $2 : -1$
- (d) $1 : -2$

Question 6. Ionisation energy for hydrogen atom in the ground state is E . What is the ionisation energy of Li^{++} atom in the 2nd excited state:

- (a) E
- (b) $3E$

- (c) 6E
(d) 9E

Question 7. Hydrogen (H_1^1), deuterium (H_1^2), singly ionised helium (He_2^4)⁺ and doubly ionised lithium (Li_3^6)⁺⁺ all have one electron around their nucleus. Consider an electron transition from $n = 2$ to $n = 1$ if the wavelengths of the emitted radiations are $\lambda_1, \lambda_2, \lambda_3$ and λ_4 respectively then approximately which of the following is correct?

- (a) $4\lambda_1 = 2\lambda_2 = 2\lambda_3 = \lambda_4$
(b) $\lambda_1 = 2\lambda_2 = 2\lambda_3 = \lambda_4$
(c) $\lambda_1 = \lambda_2 = 4\lambda_3 = 9\lambda_4$
(d) $\lambda_1 = 2\lambda_2 = 3\lambda_3 = 4\lambda_4$

Question 8. As an electron makes a transition from an excited state to the ground state of a hydrogen like atom/ion:

- (a) its kinetic energy increases but potential energy and total energy decrease
(b) kinetic energy, potential energy and total energy decrease
(c) kinetic energy decreases, potential energy increases but total energy remains the same
(d) kinetic energy and total energy decrease but potential energy increases

Question 9. An electron from various excited states of hydrogen atom emits radiation to come to the ground state. Let λ_n, λ_g be the de-Broglie wavelength of the electron in the n th state and the ground state respectively. Let Λ_n be the wavelength of the emitted photon in the transition from the n th state to the ground state. For large n (A, B are constants)

- (a) $\Lambda_n = A + B\lambda_n$
(b) $\Lambda_n = A + B\lambda_n^2$
(c) $\Lambda_n^2 = X$
(d) $\Lambda_n = A + \frac{B}{\lambda_n^2}$

Question 10. A spectral line is emitted when an electron:

- (a) jumps from lower orbit to higher orbit.
(b) jumps from higher orbit to lower orbit.
(c) rotates in a circular orbit.
(d) rotates in an elliptical orbit.

Question 11. The ionisation potential of hydrogen is 13.6 V. The energy of the atom in $n = 2$ state will be:

- (a) -10.2 eV

- (b) -6.4eV
- (c) -3.4 eV
- (d) -4.4 eV

Question 12. At the time of total solar eclipse, the spectrum of solar radiation would be:

- (a) a large number of dark Fraunhofer lines
- (b) a small number of dark Fraunhofer lines.
- (c) All Fraunhofer lines changed into brilliant colours.
- (d) None of these.

Question 13. The adjoining figure indicates the energy levels of a certain atom when the system moves from $2E$ to E level, a photon of wavelength λ is emitted.

The wavelength of photon produced during its transition from $\frac{4E}{3}$ to E is

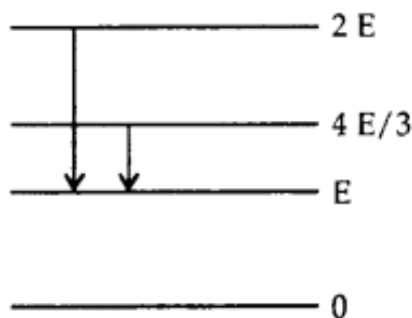

- (a) $\frac{\lambda}{3}$
- (b) $\frac{3\lambda}{4}$
- (c) $\frac{4\lambda}{3}$
- (d) 3λ

Question 14. A hydrogen atom is in the p-state. For this, values of J are

- (a) $\frac{5}{2}, \frac{3}{2}, \frac{1}{2}$
- (b) $\frac{3}{2}, \frac{1}{2}$
- (c) $-\frac{1}{2}, \frac{1}{2}, \frac{3}{2}$
- (d) $-\frac{1}{2}, \frac{-3}{2}$

Question 15. Energy levels A, B, C of a certain atom correspond to increasing value of energy i.e., $E_A > E_B > E_C$. If λ_1, λ_2 and λ_3 are the wavelengths of radiation corresponding to transition C to B, B to A and C to A respectively, which of these of the following is correct?

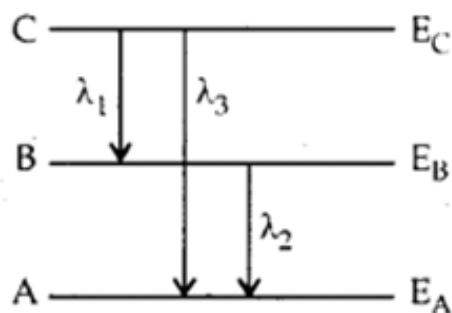

(a) $\lambda_3 = \lambda_1 + \lambda_2$

(b) $\lambda_3 = \frac{\lambda_1 \lambda_2}{\lambda_1 + \lambda_2}$

(c) $\lambda_1 + \lambda_2 + \lambda_3 = 0$

(d) $\lambda_3^2 = \lambda_1^2 + \lambda_2^2$

Very Short :

Question 1. Name the spectral series which lies in the visible region.

Question 2. What is the maximum number of spectral lines emitted by a hydrogen atom when it is in the third excited state? (CBSE AI 2013C)

Question 3. When is H_α line of the Balmer series in the emission spectrum of hydrogen atom obtained? (CBSE Delhi 2013C) when an electron jumps from $n = 3$ to $n = 2$ level.

Question 4. A mass of lead is embedded in a block of wood. Radiations from a radioactive source incident on the side of the block produce a shadow on a fluorescent screen placed beyond the block. The shadow of the wood is faint but the shadow of lead is dark. Give a reason for this difference.

Question 5. What was the source of alpha particles in Rutherford's alpha scattering experiment?

Question 6. If the radius of the ground level of a hydrogen atom is 5.3 nm, what is the radius of the first excited state?

Question 7. Calculate the ratio of energies of photons produced due to the transition of electron of a hydrogen atom from its:

(a) Second permitted energy level to the first level, and

(b) Highest permitted energy level to the second permitted level.

Question 8. The mass of an H-atom is less than the sum of the masses of a proton and electron. Why is this? (NCERT Exemplar)

Question 9. Name the series of hydrogen spectrum lying in ultraviolet and visible region.

Question 10. What is Bohr's quantisation condition for the angular momentum of an electron in the second orbit?

Short Questions :

Question 1. Define electron-volt and atomic mass unit. Calculate the energy in joule equivalent to the mass of one proton.

Question 2. State Bohr's quantization condition of angular momentum. Calculate the shortest wavelength of the Brackett series and state to which part of the electromagnetic spectrum does it belong. (CBSE Delhi 2019)

Or

Calculate the orbital period of the electron in the first excited state of the hydrogen atom.

Question 3. Write two important limitations of the Rutherford nuclear model of the atom. (CBSE AI2018, Delhi 2018)

Question 4. Find out the wavelength of the electron orbiting in the ground state of the hydrogen atom. (CBSEAI 2018, Delhi 2018)

Question 5. (a) State Bohr's postulate to define stable orbits in a hydrogen atom. How does de Broglie's hypothesis explain the stability of these orbits?

(b) A hydrogen atom initially in the ground state absorbs a photon which excites it to the $n = 4$ level. Estimate the frequency of the photon. (CBSE AI 2018, Delhi 2018)

Question 6. An alpha particle moving with initial kinetic energy K towards a nucleus of atomic number Z approaches a distance ' d ' at which it reverses its direction. Obtain an expression for the distance of closest approach ' d ' in terms of the kinetic energy of the alpha particle, K . (CBSEAI2016C)

Question 7. The figure shows the energy level diagram of the hydrogen atom.

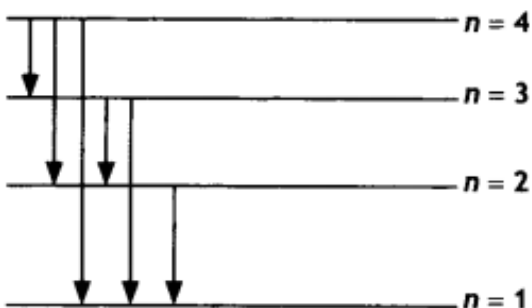

(a) Find out the transition which results in the emission of a photon of wavelength 496 nm.

(b) Which transition corresponds to the emission of radiation of maximum wavelength? Justify your answer. (CBSE AI 2015 C)

Question 8. A nucleus makes a transition from one permitted energy level to another level of lower energy. Name the region of the electromagnetic spectrum

to which the emitted photon belongs. What is the order of its energy in electron-volts? Write four characteristics of nuclear forces.

Question 9. In accordance with the Bohr's model, find the quantum number that characterises the earth's revolution around the sun in an orbit of radius

$$1.5 \times 10^{11} \text{m}$$

with orbital speed

$$3 \times 10^4 \text{m/s}$$

(Mass of earth.)

$$= 6.0 \times 10^{24} \text{kg}$$

Question 10. The total energy of an electron in the first excited state of the hydrogen atom is about

$$-3.4 \text{eV.}$$

- What is the kinetic energy of the electron in this state?
- What is the potential energy of the electron in this state?
- Which of the answers above would change if the choice of the zero of potential energy is changed?

(a)

Long Questions:

Question 1. Explain Rutherford's experiment on the scattering of alpha particles and state the significance of the results.

Question 2. Using Bohr's postulates, obtain the expression for the total energy of the electron in the stationary states of the hydrogen atom. Hence draw the energy level diagram showing how the line spectra corresponding to the Balmer series occur due to the transition between energy levels. (CBSE Delhi 2013)

Question 3. Hydrogen atoms are excited with an electron beam of energy of 12.5 eV. Find

- The highest energy level up to which the hydrogen atoms will be excited.
- The longest wavelengths in the (i) Lyman series, (ii) Balmer series of the spectrum of these hydrogen atoms. (CBSE 2019C)

Question 4. Using Bohr's postulates of the atomic model derive the expression for the radius of the n^{th} electron orbit. Hence obtain the expression for Bohr's radius. (CBSE AI 2014)

Question 5. State Bohr's postulate of the hydrogen atom which successfully explains the emission lines in the spectrum of the hydrogen atoms.

Use the Rydberg formula to determine the wavelength of H α line. [Given Rydberg constant $R = 1.03 \times 10^7 \text{ m}^{-1}$] (CBSE AI 2015)

Question 6. Using Bohr's postulates derive the expression for the frequency of radiation emitted when an electron in a hydrogen atom undergoes a transition from a higher energy state (quantum number n_1) to the lower energy state (n_2). When an electron in a hydrogen atom jumps from the energy state $n_1 = 4$ to $n = 3, 2, 1$, identify the spectral series to which the emission lines belong. (CBSE Delhi 2011C)

Question 7. Calculate the ratio of the frequencies of the radiation emitted due to the transition of the electron in a hydrogen atom from its (i) second permitted energy level to the first level and (ii) highest permitted energy level to the second permitted level. (CBSE Delhi 2018C)

Question 8. Monochromatic radiation of wavelength 975 Å excites the hydrogen atom from its ground state to a higher state. How many different spectral lines are possible in the resulting spectrum? Which transition corresponds to the longest wavelength amongst them? (CBSE Sample Paper 201819)

Question 9.

(a) Using postulates of Bohr's theory of hydrogen atom, show that

(i) the radii of orbits increase as n^2 , and

(ii) the total energy of the electron increases as $1/n^2$, where n is the principal quantum number of the atom.

(b) Calculate the wavelength of H β line in Balmer series of hydrogen atom, given Rydberg constant $R = 1.097 \times 10^7 \text{ m}^{-1}$. (CBSE AI 2011C)

Question 10. State Bohr's quantization condition for defining stationary orbits. How does de Broglie hypothesis explain the stationary orbits?

Find the relation between the three wavelengths λ_1 , λ_2 and λ_3 from the energy level diagram shown below. (CBSE Delhi 2016)

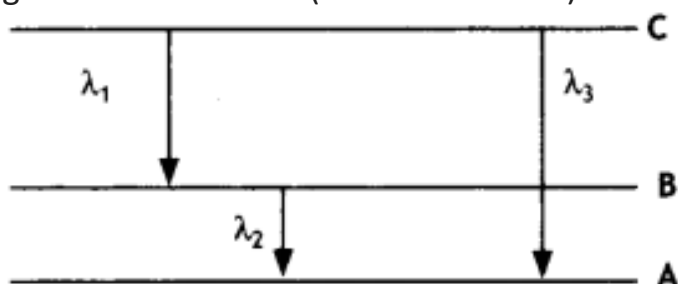

Assertion and Reason Questions-

1. For question two statements are given-one labelled Assertion (A) and the other labelled Reason (R). Select the correct answer to these questions from the codes (a), (b), (c) and (d) as given below.

- (i) Both A and R are true, and R is the correct explanation of A.
- (ii) Both A and R are true, but R is NOT the correct explanation of A.
- (iii) A is true, but R is false.
- (iv) A is false and R is also false.

Assertion (A): Total energy of revolving electron in any stationary orbit is negative.

Reason (R): Energy is a scalar quantity. It can have positive or negative value.

2. For question two statements are given-one labelled Assertion (A) and the other labelled Reason (R). Select the correct answer to these questions from the codes (a), (b), (c) and (d) as given below.

- a. Both A and R are true, and R is the correct explanation of A.
- b. Both A and R are true, but R is NOT the correct explanation of A.
- c. A is true, but R is false.
- d. A is false and R is also false.

Assertion (A): In He-Ne laser, population inversion takes place between energy levels of neon atoms.

Reason (R): Helium atoms have a meta-stable energy level.

Case Study Questions-

1. Hydrogen spectrum consists of discrete bright lines in a dark background, and it is specifically known as hydrogen emission spectrum. There is one more type of hydrogen spectrum that exists where we get dark lines on the bright background, it is known as absorption spectrum. Balmer found an empirical formula by the observation of a small part of this spectrum, and it is represented

by $\frac{1}{\lambda} = R \left(\frac{1}{2^2} - \frac{1}{n^2} \right)$ where $n = 3, 4, 5$ For Lyman series, the emission is from first state to n^{th} state, for Paschen series, it is from third state to n^{th} state, for Brackett series, it is from fourth state to n^{th} state and for Pfund series, it is from fifth state to n^{th} state.

- (i) Number of spectral lines in hydrogen atom is:
 - a) 8
 - b) 6
 - c) 15

- d) ∞
- (ii) Which series of hydrogen spectrum corresponds to ultraviolet region?
- a) Balmer series.
 - b) Brackett series.
 - c) Paschen series.
 - d) Lyman series.
- (iii) Which of the following lines of the H-atom spectrum belongs to the Balmer series?
- a) 1025A
 - b) 1218A
 - c) 4861A
 - d) 18751A
- (iv) Rydberg constant is.
- a) A universal constant.
 - b) A universal constants.
 - c) Different for different elements.
 - d) None of these.
- (v) Hydrogen atom is excited from ground state to another state with principal quantum number equal to 4. Then the number of spectral lines in the emission spectra will be.
- a) 3
 - b) 5
 - c) 6
 - d) 2

2. In 1911, Rutherford, along with his assistants, H. Geiger and E. Marsden, performed the alpha particle scattering experiment. H. Geiger and E. Marsden took radioactive source ${}_{83}^{214}\text{Bi}$ for α - particles. A collimated beam of α -particles of energy 5.5 MeV was allowed to fall on 2.1×10^{-7} m thick gold foil. The α -particles were observed through a rotatable detector consisting of a Zinc sulphide screen and microscope. It was found that CL-particles got scattered. These scattered α -particles produced scintillations on the zinc sulphide screen. Observations of this experiment are as follows.

Most of the α -particles passed through the foil without deflection.

Only about 0.14% of the incident α -particles scattered by more than 1°

Only about one α -particle in every 8000 α -particles deflected by more than 90°

These observations led to many arguments and conclusions which laid down the structure of the nuclear model of an atom.

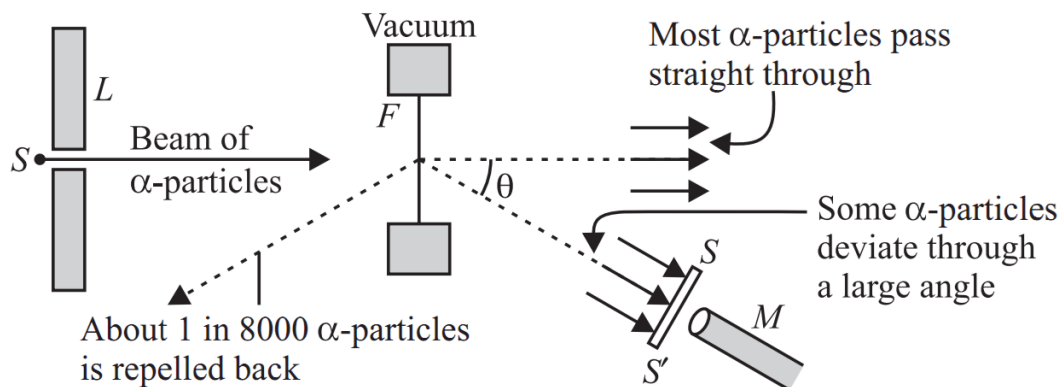

(i) Rutherford's atomic model can be visualised as.

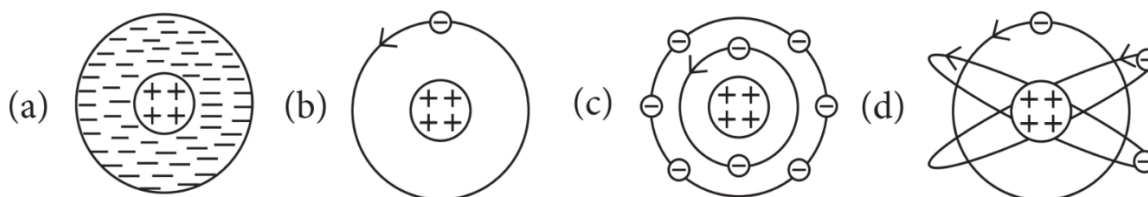

(ii) Gold foil used in Geiger-Marsden experiment is about 10^{-8} m thick. This ensures.

- Gold foil's gravitational pull is small or possible.
- Gold foil is deflected when α -particle stream is not incident centrally over it.
- Gold foil provides no resistance to passage of α -particles.
- Most α -particle will not suffer more than 1° scattering during passage through gold foil.

(iii) In Geiger-Marsden scattering experiment, the trajectory traced by an α -particle depends on.

- Number of collision.
- Number of scattered α - particles.
- Impact parameter.
- None of these.

- (iv) In the Geiger-Marsden scattering experiment, in case of head-on collision, the impact parameter should be.
- Maximum
 - Minimum
 - Infinite
 - zero
- (v) The fact only a small fraction of the number of incident particles rebound back in Rutherford scattering indicates that.
- Number of α -particles undergoing head-on-collision is small.
 - Mass of the atom is concentrated in a small volume.
 - Mass of the atom is concentrated in a large volume.
 - Both (a) and (b).

Multiple Choice Answers-

- Answer: (a) of the electrons not being subject to a central force.
- Answer: (a) in general, to any of the states with lower energy.
- Answer: (c) 13.6 eV, -27.2 eV
- Answer: (c) $V_L/25$
- Answer: (b) 1 : -1
- Answer: (a) E
- Answer: (c) $\lambda_1 = \lambda_2 = 4\lambda_3 = 9\lambda_4$
- Answer: (a) its kinetic energy increases but potential energy and total energy decrease
- Answer:

(d) $\Lambda_n = A + \frac{B}{\lambda_n^2}$
- Answer: (b) jumps from higher orbit to lower orbit.
- Answer: (c) - 3.4 eV
- Answer: (c) All Fraunhofer lines changed into brilliant colours.
- Answer: (d) 3λ
- Answer: (b) $\frac{3}{2}, \frac{1}{2}$
- Answer:

$$(b) \lambda_3 = \frac{\lambda_1 \lambda_2}{\lambda_1 + \lambda_2}$$

Very Short Answers:

1. Answer: Balmer series
2. Answer: Six.
3. Answer: It is obtained
4. Answer: The shadow of the wood is faint because only the α -radiations are stopped by the wood (since α -radiations are least penetrating). The shadow of lead is dark because β and γ -radiations are also stopped by lead.
5. Answer: The source was ${}^{214}_{83}\text{Bi}$.
6. Answer: It is $4 \times 5.3 = 21.2 \text{ nm}$ ($\because r = n^2 r_0$)
7. Answer:
 (b) energy of photon $E_1 = -3.4 - (-13.6) = 10.2 \text{ eV}$
 (c) energy of photon $E_2 = 0 - (-3.4) = 3.4 \text{ eV}$
 Ratio $\frac{E_1}{E_2} = \frac{10.2}{3.4} = 3$
8. Answer: Einstein's mass-energy equivalence gives $E = mc^2$. Thus the mass of an H-atom is $m_p + m_e - B/c^2$ where $B \approx 13.6 \text{ eV}$
9. Lyman series lies in ultraviolet region while Balmer series lies in visible region.
10. We know that,

$$L = \frac{nh}{2\pi}$$

We are given,

$$n = 2$$

$$\Rightarrow L = \frac{2h}{2\pi}$$

$$\therefore L = \frac{h}{\pi}$$

Therefore, Bohr's quantisation condition for the angular momentum of an electron in the second orbit is found to be,

$$L = \frac{h}{\pi}$$

Short Questions Answers :

1. Answer: Electron volt: It is defined as the energy gained by an electron when accelerated through a potential difference of 1 volt. Atomic mass unit: It is defined as one-twelfth of the mass of one atom of carbon 12.

The mass of a proton is 1.67×10^{-27} kg. Therefore, energy equivalent of this mass is $E = mc^2 = 1.67 \times 10^{-27} \times (3 \times 10^8)^2 = 1.5 \times 10^{-10}$ J

2. Answer: Bohr's Quantisation condition: Only those orbits are permitted in which the angular momentum of the electron is an integral multiple of $h/2\pi$.

For Brackett Series,

The shortest wavelength is for the transition of electrons from $n_i = \infty$ to $n_f = 4$

Using the equation

$$\frac{1}{\lambda} = R \left(\frac{1}{n_f^2} - \frac{1}{n_i^2} \right)$$

$$\frac{1}{\lambda} = R \left(\frac{1}{4^2} - \frac{1}{\infty^2} \right) = \frac{R}{16}$$

$$\text{Or } \lambda = \frac{16}{R} = \frac{16}{1.09 \times 10^7} = 1467.8 \text{ nm}$$

OR

First excited state $n = 2$, $T = ?$

$$T = \frac{2\pi r}{v} = \frac{n^3 h^3}{4 \pi^2 m e^4 k^2} \text{ where } k = \frac{1}{4\pi\epsilon_0}$$

Substituting the values, we have

$$T = \frac{(2)^3 (6.6 \times 10^{-34})^3}{4 \times (3.14)^2 \times 9.1 \times 10^{-31} \times (1.6 \times 10^{-19})^4 \times (9 \times 10^9)^2}$$

$$T = 1.22 \times 10^{-15} \text{ s}$$

3. Answer:

1. Rutherford's model fails to explain the line spectra of the atom.
2. Rutherford's model cannot explain the stability of the nucleus.

4. Answer: The wavelength of an electron in the ground state of hydrogen atom is given by

$$E = \frac{hc}{\lambda}$$

or

$$\lambda = \frac{hc}{E}$$

For ground state

$$E = -13.6 \text{ eV} = 13.6 \times 1.6 \times 10^{-19} \text{ J}$$

Hence wavelength of electron in the first orbit

$$\lambda = \frac{hc}{E} = \frac{6.6 \times 10^{-34} \times 3 \times 10^8}{13.6 \times 1.6 \times 10^{-19}} = 0.9 \times 10^{-7} \text{ m}$$

5. Answer: (a) Bohr's postulate for stable orbits states the electron in an atom revolves around the nucleus only in those orbits for which its angular momentum is an integral multiple of $h/2\pi$ (h = Planck's constant), ($n = 1, 2, 3 \dots$)

As per de Broglie's hypothesis $\lambda = h/p = h/mv$

For a stable orbit, we must have a circumference of the orbit = $n\lambda$ ($n = 1, 2, 3, \dots$)

$$\therefore 2\pi r = n\lambda$$

or

$$mvr = nh/2\pi$$

Thus de-Broglie showed that the formation of stationary patterns for integral "n" gives rise to the stability of the atom.

This is nothing but Bohr's postulate.

(b) Energy in the $n = 4$ level $n_1 = 1$ and $n_2 = 4$

$$\begin{aligned} \therefore \frac{1}{\lambda} &= R_H \left(\frac{1}{n_1^2} - \frac{1}{n_2^2} \right) \\ &= R_H \left(\frac{1}{1^2} - \frac{1}{4^2} \right) \\ &= R_H \left(1 - \frac{1}{16} \right) = R_H \left(\frac{15}{16} \right) \quad \dots (i) \end{aligned}$$

$$\begin{aligned} \therefore v &= \frac{c}{\lambda} \\ &= c \times \frac{1}{\lambda} \end{aligned}$$

From eqn (i)

$$\begin{aligned} v &= c \times R_H \left(\frac{15}{16} \right) \\ &= 3 \times 10^8 \times 1.09 \times 10^7 \left(\frac{15}{16} \right) \end{aligned}$$

$$\therefore v = 3.1 \times 10^{15} \text{ Hz}$$

6. Answer: At the distance of the closest approach, the kinetic energy of the alpha particle is converted into the electrostatic potential energy of the alpha particle-nucleus system. Therefore, at the distance of the closest approach

we have

Kinetic energy = Potential energy

Therefore,

$$\frac{1}{2}mv^2 = \frac{1}{4\pi\epsilon_0} \frac{2Ze^2}{r_{\min}}$$

$$\text{or } r_{\min} = \frac{1}{4\pi\epsilon_0} \frac{2Ze^2}{K}$$

where K is the kinetic energy.

$$\frac{1}{\lambda} = R_H \left(\frac{1}{n_f^2} - \frac{1}{n_i^2} \right)$$

7. Answer: (a) The wavelength of photon emitted is given by

None of these transitions correspond to a wavelength of 496 nm. The closest is 4 to 2 of 489 nm

(b) Transition 4 to 3 as the frequency of this radiation is maximum.

8. Answer: (a) Emitted photon belongs to gamma-rays part of the electromagnetic spectrum.

(b) the energy is of the order of MeV.

(c) Four characteristics of nuclear forces are:

- 1) Nuclear forces are independent of charges.
- 2) Nuclear forces are short-range forces.
- 3) Nuclear forces are the strongest forces in nature, in their own small range of few fermis.
- 4) Nuclear forces are saturated forces.

9. Answer: We are given:

Radius of the orbit of the Earth around the Sun,

$$r = 1.5 \times 10^{11} \text{m}$$

Orbital speed of the Earth,

$$v = 3 \times 10^4 \text{m/s}$$

Mass of the Earth,

$$m = 6.0 \times 10^{24} \text{kg}$$

According to Bohr's model, angular momentum is quantized and could be given as:

$$Mvr = \frac{nh}{2\pi}$$

Where,

$$h =$$

Planck's constant

$$= 6.62 \times 10^{-34} \text{ Js}$$

$$n =$$

Quantum number

$$\Rightarrow n = \frac{mvr2\pi}{h}$$

$$\Rightarrow n = \frac{2\pi \times 6 \times 10^{24} \times 3 \times 10^4 \times 1.5 \times 10^{11}}{6.62 \times 10^{-34}}$$

$$\therefore n = 25.61 \times 10^{73} = 2.6 \times 10^{74}$$

Hence, the quanta number that characterizes the Earth's revolution is found to be

$$2.6 \times 10^{74}.$$

10. Answer: (a) We are given,

Total energy of the electron,

$$E = -3.4 \text{ eV}$$

Kinetic energy of the electron is equal to the negative of the total energy.

$$\Rightarrow \text{K.E} = -E$$

$$\therefore \text{K.E} = -(-3.4) = +3.4 \text{ eV}$$

Hence, the kinetic energy of the electron in the given state is found to be

$$+3.4 \text{ eV}.$$

(b) We know that, the potential energy (U) of the electron is found to be equal to the negative of twice of its kinetic energy.

$$\Rightarrow U = -2\text{K.E}$$

$$\therefore U = -2 \times 3.4 = -6.8 \text{ eV}$$

Hence, the potential energy of the electron in the given state is found to be

$$-6.8 \text{ eV}.$$

(d) We know that, the potential energy of a system would depend on the reference point taken. Here, the potential energy of the reference

point is taken to be zero. On changing the reference point, then the value of the potential energy of the system would also change. Since, we know that total energy is the sum of kinetic and potential energies, total energy of the system will also change.

Long Questions Answers :

1. Answer: The schematic arrangement in the Geiger Marsden experiment is shown in the figure.

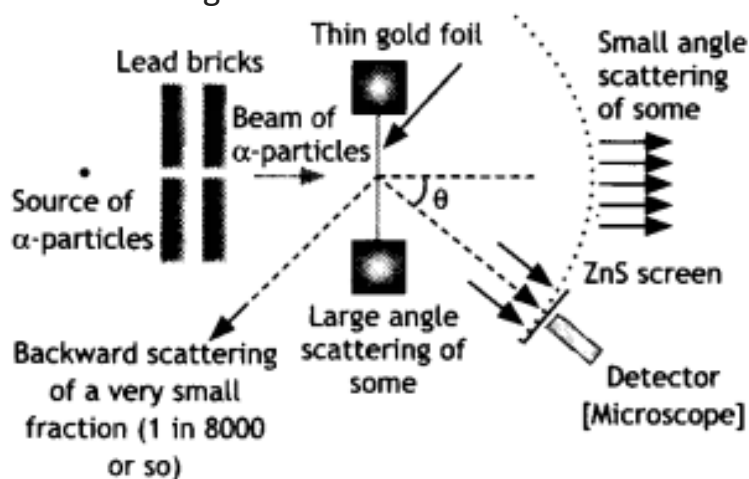

Alpha-particles emitted by a Bismuth ($^{214}_{83}\text{Bi}$) radioactive source were collimated into a narrow beam by their passage through lead bricks. The beam was allowed to fall on a thin foil of gold of thickness 2.1×10^{-7} m. The scattered alpha-particles were observed through a rotatable detector consisting of a zinc sulfide screen and a microscope. The scattered alpha-particles on striking the screen produced bright light flashes or scintillations. These scintillations could be viewed through the microscope and counted at different angles from the direction of the incident beam.

Significance: The experiment established the existence of a nucleus that contained the entire positive charge and about 99.95% of the mass.

2. Answer: The electron revolving around the nucleus has two types of energy:

Kinetic energy due to its motion.

Potential energy due to it lying in the electric field of the nucleus.

Thus the total energy of the electron is given by

$$E = K. E. + P. E. \dots(1)$$

An electron of mass m moving around the nucleus with an orbital velocity v has kinetic energy given by

$$K.E. = \frac{1}{2}mv^2 = \frac{1}{2} \frac{ke^2}{r} \dots(2)$$

Now the potential energy of the electron at a distance r from the nucleus is given by

PE = potential due to the nucleus at a distance $r \times$ charge on the electron = $V \times -e$... (3)

Now the potential at a distance r from the nucleus having a charge e is given by

$$V = k \frac{e}{r} \dots (4)$$

Substituting in equation (3) we have

$$\text{P.E.} = V \times -e = -k \frac{e^2}{r} \dots (5)$$

Substituting equations (2) and (3) in equation 1 we have

$$\begin{aligned} E = \text{K.E.} + \text{P.E.} &= \frac{1}{2} \frac{k e^2}{r} - \frac{k e^2}{r} \\ &= -\frac{1}{2} \frac{k e^2}{r} \quad \dots (6) \end{aligned}$$

But the radius of the n th orbit is given by

$$r_n = \frac{n^2 h^2}{4\pi^2 m e^2 k}$$

Substituting in equation (6) we have

$$E = -\frac{2\pi^2 m e^4 k^2}{n^2 h^2} \dots (7)$$

This gives the expression for the energy possessed by the electron in the n th orbit of the hydrogen atom.

3. Answer: (a) The maximum energy that the excited hydrogen atom can have is

$$E = -13.6 \text{ eV} + 12.5 \text{ eV}$$

$$\text{or } E = -1.1 \text{ eV}$$

$$\text{Since } E_n = \frac{-13.6}{n^2} \text{ eV}$$

$$\therefore \text{ For } n=1, E_1 = -13.6 \text{ eV } (< 1.1 \text{ eV})$$

$$\text{For } n=2, E_2 = \frac{-13.6}{4} = -3.4 \text{ eV}$$

$$(< -1.1 \text{ eV})$$

$$\text{For } n=3, E_3 = \frac{-13.6}{9} = -1.5 \text{ eV}$$

$$(< -1.1 \text{ eV})$$

$$\text{For } n=4, E_4 = \frac{-13.6}{16} = -0.85 \text{ eV}$$

$$(> -1.1 \text{ eV})$$

∴ The electron can only be excited up to $n = 3$ states.

(b) From energy level of hydrogen atom, we have

$$\frac{1}{\lambda} = R \left[\frac{1}{n_1^2} - \frac{1}{n_2^2} \right]$$

Longest wavelength of Lyman series

$$\frac{1}{\lambda_L} = R \left[\frac{1}{1^2} - \frac{1}{2^2} \right] = \frac{3}{4} R$$

$$\text{or } \lambda_L = \frac{4}{3R} = \left(\frac{4}{3 \times 1.1 \times 10^7} \right) \text{m} = 1218 \text{ \AA}$$

Longest wavelength of Balmer series

$$\frac{1}{\lambda_B} = R \left[\frac{1}{2^2} - \frac{1}{3^2} \right] = \frac{5}{36} R$$

$$\therefore \lambda_B = \frac{36}{5R} = \left(\frac{36}{5 \times 1.1 \times 10^7} \right) \text{m} = 6560 \text{ \AA}$$

4. Answer: Let us consider a mechanical model of the hydrogen atom as shown in the figure that incorporates this quantization assumption.

Proton is assumed to be stationary.

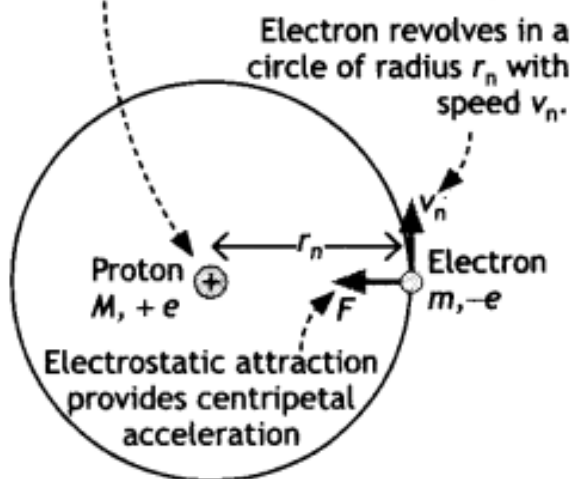

This atom consists of a single electron with mass m and charge $-e$ revolving around a single proton of charge $+e$. The proton is nearly 2000 times as massive as the electron, so we can assume that the proton does not move. As the electron revolves around the nucleus the electrostatic force of attraction between the electron and the proton provides the necessary centripetal force. Therefore, we have

$$k \frac{e^2}{r_n^2} = \frac{mv^2}{r_n}$$

$$\text{or } k \frac{e^2}{r_n} = mv^2 \quad \dots(1)$$

By Bohr's quantisation condition we have

$$mvr = \frac{nh}{2\pi}$$

$$\text{or } v = \frac{nh}{2\pi mr_n} \quad \dots(2)$$

substituting equation 2 in equation 1 we have

$$k \frac{e^2}{r_n} = m \left(\frac{nh}{2\pi mr_n} \right)^2 \quad \dots(3)$$

$$\text{Solving for } r \text{ we have } r_n = \frac{n^2 h^2}{4\pi^2 m e^2 k} \quad \dots(4)$$

This gives the radius of the nth orbit of the hydrogen atom.

If $n = 1$ we have $r = a_0$ which is called Bohr's radius.

$$a_0 = \frac{h^2}{4\pi^2 m e^2 k}$$

5. Answer: It states that an electron might make a transition from one of its specified non-radiating orbits to another of lower energy. When it does so, a photon is emitted having energy equal to the energy difference between the initial and final states. The frequency of the emitted photon is then given by

$h\nu = E_i - E_f$ where E_i and E_f are the energies of the initial and final states

Using the formula $\frac{1}{\lambda} = R_H \left(\frac{1}{n_f^2} - \frac{1}{n_i^2} \right)$ we have for Ha Line $n_i = 3$ and $n_f = 2$

$$\text{Therefore, } \frac{1}{\lambda} = 1.03 \times 10^7 \left(\frac{1}{2^2} - \frac{1}{3^2} \right)$$

$$\text{or } \lambda = \frac{36}{5 \times 1.03 \times 10^7} = 6.99 \times 10^{-7} \text{ m}$$

6. Answer: According to Bohr's frequency condition, if an electron jumps from an energy level E to E_1 , then the frequency of the emitted radiation is given by

$$h\nu = E - E_1 \quad \dots(1)$$

Let n_i and n_f be the corresponding orbits then

$$E_i = -\frac{2\pi^2 m e^4 k^2}{n_i^2 h^2} \quad \text{and} \quad E_f = -\frac{2\pi^2 m e^4 k^2}{n_f^2 h^2}$$

substituting in equation (1) we have

$$\begin{aligned} h\nu &= -\frac{2\pi^2 m e^4 k^2}{n_f^2 h^2} - \left(-\frac{2\pi^2 m e^4 k^2}{n_i^2 h^2} \right) \\ &= \frac{2\pi^2 m e^4 k^2}{h^2} \left(\frac{1}{n_f^2} - \frac{1}{n_i^2} \right) \end{aligned}$$

Rewriting the above equation we have

$$\nu = \frac{2\pi^2 m e^4 k^2}{h^3} \left(\frac{1}{n_f^2} - \frac{1}{n_i^2} \right)$$

This gives the frequency of the emitted radiation.

When $n_i = 4$ and $n_f = 3$, Paschen series

When $n_i = 4$ and $n_f = 2$, Balmer series

When $n_i = 4$ and $n_f = 1$, Lyman series

7. Answer: We have

$$h\nu = E_f - E_i$$

$$= \frac{E_0}{n_f^2} - \frac{E_0}{n_i^2}$$

$$(i) \quad h\nu_1 = E_0 \left(\frac{1}{1^2} - \frac{1}{2^2} \right) = E_0 \times \frac{3}{4}$$

$$(ii) \quad h\nu_2 = E_0 \left(\frac{1}{2^2} - \frac{1}{\infty^2} \right) = E_0 \times \frac{1}{4}$$

$$\therefore \frac{\nu_1}{\nu_2} = 3$$

8. Answer: The energy corresponding to the given wavelength:

$$E(\text{in eV}) = \frac{hc}{\lambda} = \frac{6.6 \times 10^{-34} \times 3 \times 10^8}{975 \times 10^{-10} \times 1.6 \times 10^{-19}}$$

$$= 12.71 \text{ eV}$$

The excited state:

$$E_n - E_1 = 12.71$$

$$-\frac{13.6}{n^2} - (-13.6) = 12.71$$

or $n = 4$

Total no. of spectral lines emitted:

$$\frac{n(n-1)}{2} = \frac{4(4-1)}{2} = \frac{12}{2} = 6$$

The longest wavelength Will correspond to the transition $n = 4$ to $n = 3$

9. Answer: Let us consider a mechanical. model of the hydrogen atom as shown in the figure.

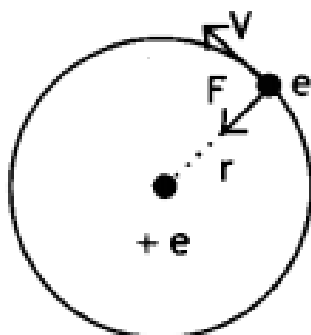

This atom consists of a single electron with mass m and charge $-e$ revolving around a single proton of charge $+e$. As the electron revolves around the nucleus the electrostatic force of attraction between the electron and the proton provides the necessary centripetal force. Therefore we have,

$$k \frac{e^2}{r_n^2} = \frac{mv^2}{r_n} \quad \dots(1)$$

$$\text{or } k \frac{e^2}{r_n} = mv^2 \quad \dots(2)$$

By Bohr's quantisation condition we

$$\text{have } mvr = \frac{nh}{2\pi}$$

$$\text{or } v = \frac{nh}{2\pi mr_n} \quad \dots(3)$$

Substituting equation 3 in equation 2 we have

$$k \frac{e^2}{r_n} = m \left(\frac{nh}{2\pi mr_n} \right)^2 \quad \dots(4)$$

$$\text{Solving for } r \text{ we have } r_n = \frac{n^2 h^2}{4\pi^2 m e^2 k} \quad \dots(5)$$

This gives the radius of the n^{th} orbit of the hydrogen atom which shows that $E \propto \frac{1}{n^2}$

(ii) the total energy possessed by an electron in the n^{th} orbit of the hydrogen atom is given by

$$E = T + U \quad \dots(1)$$

i.e. the sum of its kinetic and electrostatic potential energies.

An electron of mass m moving around the nucleus with an orbital velocity v has kinetic energy given by

$$\text{K.E.} = \frac{1}{2}mv^2 = \frac{1}{2} \frac{ke^2}{r} \quad \dots(2)$$

Now the potential energy of the electron at a distance r from the nucleus is given by

$$\begin{aligned} \text{PE} &= \text{potential due to the nucleus at a distance } r \times \text{charge on the electron} \\ &= V \times -e \quad \dots(3) \end{aligned}$$

Now the potential at a distance r from the nucleus having a charge e is given by

$$V = k \frac{e}{r} \quad \dots(4)$$

Substituting in equation 2 we have

$$P.E. = V \times -e = -k \frac{e^2}{r} \dots(5)$$

Substituting equations 2 and 5 in equation 1 we have

$$\begin{aligned} E = K.E. + P.E. &= \frac{1}{2} k \frac{e^2}{r} - \frac{k e^2}{r} \\ &= -\frac{1}{2} \frac{k e^2}{r} \quad \dots(6) \end{aligned}$$

But the radius of the nth orbit is given by

$$r_n = \frac{n^2 h^2}{4\pi^2 m e^2 k}$$

Substituting in equation 6 we have

$$E = -\frac{2\pi^2 m e^4 k^2}{n^2 h^2} \dots(7)$$

This gives the expression for the energy possessed by the electron in the nth orbit of the hydrogen atom which shows that $E \propto \frac{1}{n^2}$

(b) For H₂ Line in Balmer series $n_1 = 2$ and $n_2 = 3$

$$\frac{1}{\lambda} = 1.097 \times 10^7 \left[\frac{1}{4} - \frac{1}{9} \right] = 1.097 \times 10^7 \times \frac{5}{36}$$

$$\text{or } \lambda = 656.3 \text{ nm}$$

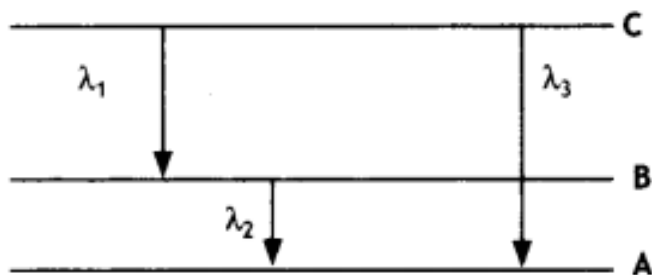

10. Answer: It states that only those orbits are permitted in which the angular momentum of the electron about the nucleus is an integral multiple of $\frac{h}{2\pi}$, where h is Planck's constant.

According to de Broglie, an electron of mass m moving with speed v would have a wavelength λ given by

$$\lambda = h/mv.$$

Now according to Bohr's postulate,

$$mvr_n = \frac{nh}{2\pi}$$

or

$$2\pi r_n = \frac{nh}{mv}$$

But $h/mv = \lambda$ is the de Broglie wavelength of the electron, therefore, the above equation becomes $2\pi r_n = n\lambda$ where $2\pi r_n$ is the circumference of the permitted orbit. If the wavelength of a wave does not close upon itself, destructive interference takes place as the wave travels around the loop and quickly dies out. Thus only waves that persist are those for which the circumference of the circular orbit contains a whole number of wavelengths.

$$\Delta E_3 = \Delta E_1 + \Delta E_2$$

$$\frac{hc}{\lambda_3} = \frac{hc}{\lambda_1} + \frac{hc}{\lambda_2}$$

$$\text{or } \frac{1}{\lambda_3} = \frac{1}{\lambda_1} + \frac{1}{\lambda_2}$$

$$\frac{1}{\lambda_3} = \frac{\lambda_2 + \lambda_1}{\lambda_1 \lambda_2}$$

$$\lambda_3 = \frac{\lambda_1 \lambda_2}{\lambda_1 + \lambda_2}$$

Numerical Problem :

Formulae for solving numerical problems

- Distance of closest approach $r_o = \frac{1}{4\pi\epsilon_0} \frac{2zE^2}{E_k}$
- Radius of the nth orbit of hydrogen atom $r_n = \frac{n^2 h^2}{4\pi^2 m e^2 k}$
- Velocity of electron in the nth orbit $v = v = \frac{c}{137n}$
- Wavelength of radiation emitted when electron jumps from n_i to n_f $\frac{1}{\lambda} = R_H \left(\frac{1}{n_f^2} - \frac{1}{n_i^2} \right)$
- Energy of electron in the nth orbit of hydrogen atom

$$E = - \frac{2\pi^2 m e^4 k^2}{n^2 h^2}$$

or

$$E = - \frac{13.6}{n^2} \text{ eV}$$

Assertion and Reason Answers-

1. (b) Both A and R are true, but R is NOT the correct explanation of A.

Explanation:

The reason is correct, but does not explain the assertion properly. Negative energy of revolving electron indicates that it is bound to the nucleus. The electron is not free to leave the nucleus.

2. (a) Both A and R are true, and R is the correct explanation of A.

Explanation:

Helium-neon laser uses a gaseous mixture of helium and neon. An electric discharge in the gas pumps the helium atoms to higher energy level, (which is meta stable energy level).

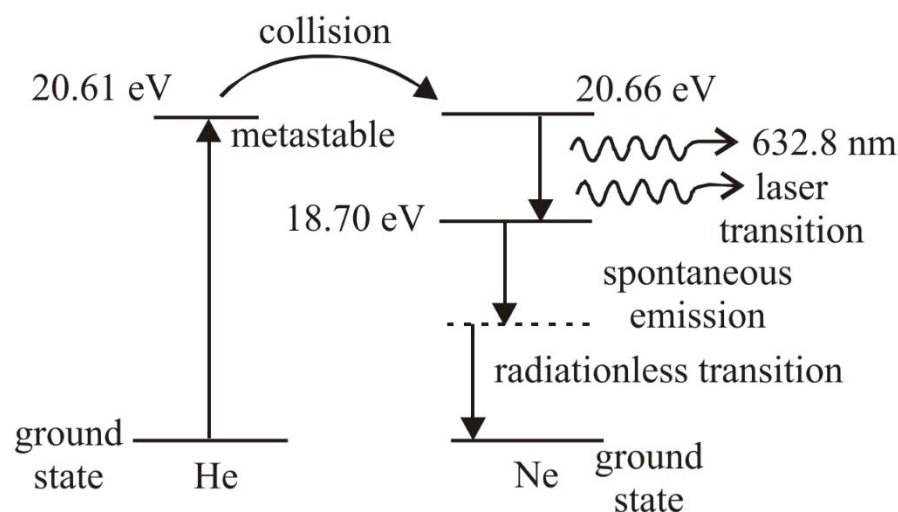

Sequence of transitions in He-Ne laser.

Then these helium atom excite the neon atoms to higher level by collision and produce an inverted population of neon atom which emit radiation when they are stimulated to fall to lower level.

Case Study Answers-

1. Answer :

(i) (d) ∞

Explanation:

Number of spectral lines in hydrogen atom is ∞

(ii) (d) Lyman series

Explanation:

Lyman series lies in the ultraviolet region

(iii) (c) 4861 Å

Explanation:

The shortest Balmer line has energy = $13.6 \left(\frac{1}{2^2} - \frac{1}{3^2} \right) \text{eV} = 1.89 \text{eV}$

and the highest energy = $13.6 \left(\frac{1}{2^2} - \frac{1}{\infty} \right) = 3.4 \text{eV}$ The corresponding wavelengths are

$$\frac{12400 \text{eVÅ}}{1.89 \text{eV}} = 6561 \text{Å} \text{ and } \frac{12400 \text{eVÅ}}{3.4 \text{eV}} = 3647 \text{Å}$$

Only 4861 Å is between the first and last line of the Balmer series.

(iv) (a) A universal constant.

(v) (c) 6

2. Answer :

(i) (d)

(d)

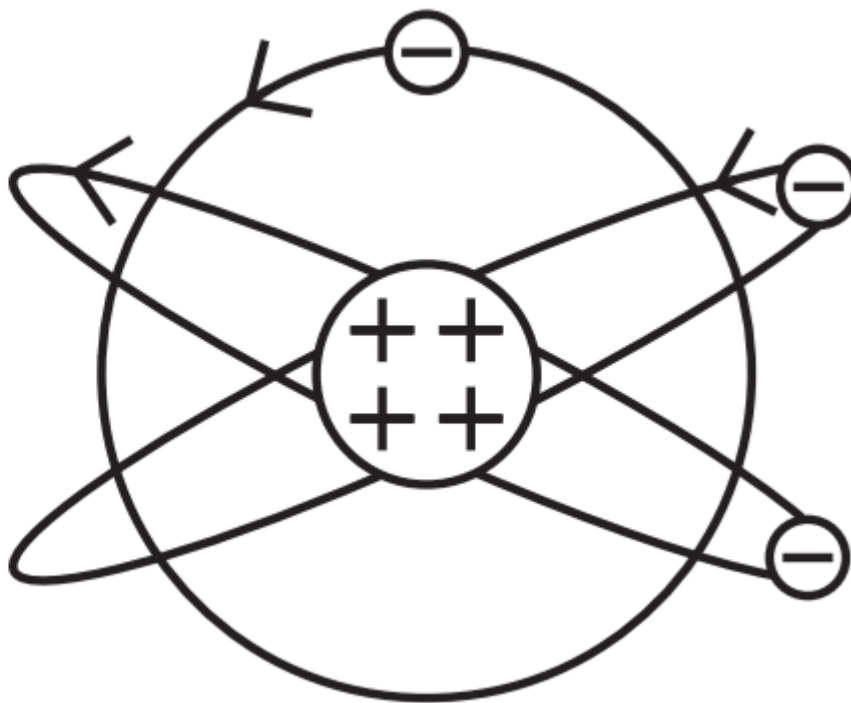

Explanation:

Rutherford's atom had a positively charged centre and electrons were revolving outside it. It is also called the planetary model of the atom, as in option (d).

(ii) (d) Most α -particle will not suffer more than 1° scattering during passage through gold foil.

Explanation:

As the gold foil is very thin, it can be assumed that α -particles will suffer not more than one scattering during their passage through it. Therefore, computation of the trajectory of an α -particle scattered by a single nucleus is enough.

(iii) (c) Impact parameter

Explanation:

Trajectory of α -particles depends on impact parameter, which is the perpendicular distance of the initial velocity vector of the α particles from the centre of the nucleus. For small impact parameter, α particle close to the nucleus suffers larger scattering.

(iv) (b) Minimum

Explanation:

At minimum impact parameter, α particles rebound back ($\theta \approx \pi$) and suffers large scattering.

(v) (d) Both (a) and (b).

Explanation:

In case of head-on-collision, the impact parameter is minimum and the α -particle rebounds back. So, the fact that only a small fraction of the number of incident particles rebound back indicates that the number of α -particles undergoing head-on collision is small. This in turn implies that the mass of the atom is concentrated in a small volume. Hence, option (a) and (b) are correct.



C V RAMAN
PUCOLLEGE
INDI

CHAPTER 13: NUCLEI

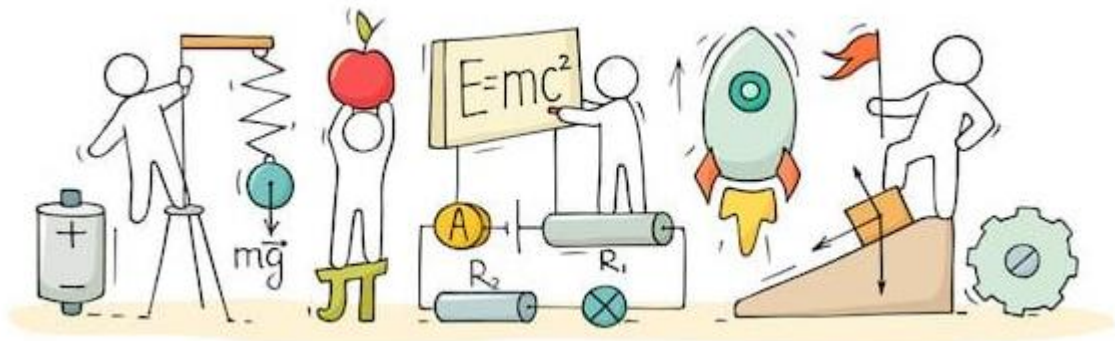

NUCLEI

Nucleus:

The entire positive charge and nearly the entire mass of atom is concentrated in a very small space called the nucleus of an atom.

The nucleus consists of protons and neutrons. They are called nucleons.

Atomic Number:

The number of protons in the nucleus is called the atomic number. It is denoted by Z.

Mass number:

The total number of protons and neutrons present in a nucleus is called the mass number of the element. It is denoted by A.

Atomic Mass Unit:

The unit in which atomic and nuclear masses are measured is called atomic mass unit (u), defined as $\frac{1}{12}$ th of the mass of an atom of ${}_{6}\text{C}^{12}$ isotope.

$$1\text{u} = \frac{1}{12} \times \frac{12}{6.02 \times 10^{23}}$$

$$1\text{u} = 1.66 \times 10^{-27}\text{kg}$$

$$1\text{amu} = 931\text{ MeV}$$

Nuclear Mass:

The total mass of the protons and neutrons present in a nucleus is called the nuclear mass.

Nuclide:

A nuclide is a specific nucleus of an atom characterized by its atomic number Z and mass number A. It is represented as, ZX^A

Where X = chemical symbol of the element, Z = atomic number and A = mass number

Isotopes:

The atoms of an element which have the same atomic number, but different mass number are called isotopes.

Isotopes have similar chemical properties but different physical properties.

Isobars:

The atoms having the same mass number, but different atomic number are called isobars.

Isotones:

The nuclides having the same number of neutrons are called isotones.

Isomers:

These are nuclei with same atomic number and same mass number but in different energy states.

Electron Volt:

It is defined as the energy acquired by an electron when it is accelerated through a potential difference of 1 volt and is denoted by eV.

Discovery of Neutron:

Neutron was discovered experimentally by Chadwick in the year 1932 and was awarded Nobel Prize in Physics in 1935 for their discovery. A neutron is a neutral particle carrying no charge and having mass roughly equal to the mass of a proton.

Now the mass of a neutron is known to a high degree of accuracy and is equal to $m_n = 1.67 \times 10^{-27}$ kg. A free neutron is unstable and has a mean life of 1000 second. Whereas a free proton is stable. Neutron is however stable inside the nucleus.

Size of the Nucleus:

- It is found that a nucleus of mass number A has a radius.

$$R = R_0 A^{\frac{1}{3}}$$

$$\text{where, } R_0 = 1.2 \times 10^{-15} \text{ m}$$

- This implies that the volume of the nucleus, which is proportional to R^3 is proportional A.

Mass-Energy and Nuclear Binding Energy:

Mass-Energy:

Einstein gave the famous mass–energy equivalence $E = mc^2$, here the energy equivalent of mass m is related by the above equation and c is the velocity of light in vacuum and is approximately equal to 3×10^8 m/s. Einstein's mass-energy relation has been experimentally verified in the study of nuclear reactions amongst nucleons, nuclei, electrons and other more recently discovered particles.

Nuclear Binding Energy:

Nucleus is made up of neutrons and protons. Therefore, mass of the nucleus (M) should be equal to the total mass of its protons and neutrons. However, it is found to be always less than this. This difference in mass (ΔM) is called the mass defect and is given by.

$$\Delta M = [Zm_p + (A - Z)m_n] - m$$

It is mass defect which appears in the form of binding energy, responsible for binding the nucleons together in the nucleus.

Nuclear Force:

The force acting inside the nucleus or acting between nucleons is called nuclear force.

- Nuclear forces are the strongest forces in nature.
- It is a very short-range attractive force.
- It is non-central. non-conservative force.
- It is neither gravitational nor electrostatic force.
- It is independent of charge.
- It is 100 times that of electrostatic force and 10^{38} times that of gravitational force.

According to the Yukawa, the nuclear force acts between the nucleon due to continuous exchange of meson particles.

Radioactivity:

It is the phenomenon of spontaneous disintegration of the nucleus of an atom with emission of one or more radiations like α -particle, β -particle or γ –rays.

Radioactive Decay:

It is a nuclear transformation process in which the radioactive rays are emitted from the nucleus of the atom. This process cannot be accelerated and slow down by any physical

or chemical process.

Radioactivity Displacement Law:

It states that:

- When a radioactive nucleus emits an α -particle, atomic number decreases by 2 and mass number decreases by 4.
- When a radioactive nucleus emits β -particle, its atomic number increases by 1 but mass number remains same.
- The emission of a γ -particle does not change the mass number or the atomic number of the radioactive nucleus. The γ -particle emission by a radioactive nucleus lowers its energy state.

Alpha Decay:

In this process, parent nucleus disintegrates to give a daughter nucleus and helium nucleus or an alpha-particle. Mass number of the daughter nucleus decreases by four units and atomic number decreases by two units. A typical example of this decay mode is.



Thus, daughter nucleus is shifted in periodic table by 2 unit in backward direction.

Beta Decay:

It is the process of emission of an electron from a radioactive nucleus. It may be represented as,

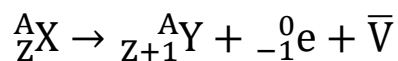

Gamma Decay:

Alpha and beta decays of a radioactive nucleus leave the daughter nucleus in an excited state. If the excitation energy available with the daughter nucleus is not sufficient for further particle emission, it loses its energy by emitting electromagnetic radiations, also known as Gamma-rays. Mass and charge of the daughter nucleus remains the same as before the emission of Gamma-rays.

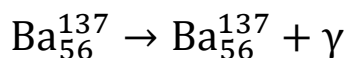

Alpha and beta decays of a radioactive nucleus leave the daughter nucleus in an excited state. If the excitation energy available with the daughter nucleus is not sufficient for further particle emission, it loses its energy by emitting electromagnetic radiations,

also known as Gamma-rays. Mass and charge of the daughter nucleus remains the same as before the emission of Gamma-rays.

Law of Radioactive Decay:

According to the law of radioactive disintegration the rate of spontaneous disintegration of a radioactive element is proportional to the number of nuclei present at that time.

Mathematically, it can be written as

$$\frac{dN}{dt} \propto N \dots (1)$$

Where, N is the number of atoms present at time t. Removing Proportionality sign, we get

$$\frac{dN}{dt} = -\lambda N \dots (2)$$

Where, λ is a constant of proportionality and is known as decay constant of the element. Negative sign indicates that as t increase N decreases.

$$\frac{dN}{N} = -\lambda dt \dots (3)$$

Integrating both sides, we have

$$\int \frac{dN}{N} = -\lambda \int dt$$

$$\log_e(N) = -\lambda t + C \dots (4)$$

where C is constant of integration and is evaluated by the fact that at $t = 0$, number of atoms of the radioactive element is N_0 . Using this condition, we get

$$C = \log_e(N_0) \dots (5)$$

Substituting this value of C in Eq. (4), we get

$$\log_e(N) = -\lambda t + \log_e(N_0)$$

$$\log_e(N) - \log_e(N_0) = -\lambda t$$

$$\text{Thus, } N = N_0 e^{-\lambda t} \dots (6)$$

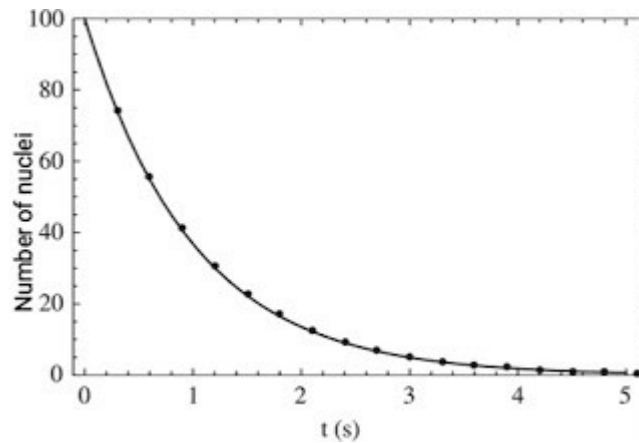

Exponential decay curve

Decay or disintegration Constant:

It may be defined as the reciprocal or the time interval in which the number of active nuclei in a given radioactive sample reduces to 36.8% of its initial value.

Half-life:

The half-life of a radioactive substance is the time in which one-half of its nuclei will disintegrate. It is inversely proportional to the decay constant of the radioactive substance.

$$T_{\frac{1}{2}} = \frac{0.693}{\lambda}$$

Mean Life:

The mean-life of a radioactive sample is defined as the ratio of the combined age of all the atoms and the total number of atoms in the given sample. It is given by,

$$\tau = \frac{T_{\frac{1}{2}}}{0.693} = 1.44T_{\frac{1}{2}}$$

Curie:

It is the SI unit of decay.

One curie is the decay rate of 3.7×10^{10} disintegrations per second.

Rutherford:

One Rutherford is the decay rate of 106 disintegrations per second.

Natural Radioactivity:

It is the phenomenon of the spontaneous emission of, α and γ radiations from the nuclei of naturally occurring isotopes.

Artificial or Induced Radioactivity:

It is the phenomenon of inducing radioactivity in certain stable nuclei by bombarding them by suitable high energy subatomic particles.

Nuclear Reaction:

It is a reaction which involves the change of stable nuclei of one element into the nucleus of another element.

Nuclear Energy:

Nuclear Fission:

The process of the splitting of a heavy nucleus into two or more lighter nuclei is called nuclear fission. When a slow-moving neutron strikes with a uranium nucleus (${}_{92}\text{U}^{235}$), it splits into ${}_{56}\text{Ba}^{144}$ and ${}_{36}\text{Kr}^{89}$ along with three neutrons and a lot of energy.

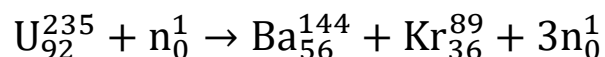

Nuclear fusion:

The process of combining of two lighter nuclei to form one heavy nucleus, is called nuclear fusion.

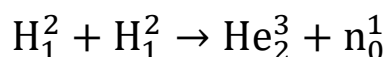

In this process, a large amount of energy is released. Hydrogen bomb is based on nuclear fusion. The source of Sun's energy is the nuclear fusion taking place at sun.

Critical size and Critical Mass:

- The size of the fissionable material for which reproduction factor is unity is called critical size and its mass is called critical mass of the material.
- The chain reaction in this case remains steady or sustained.

Moderator:

Any substance which is used to slow down fast-moving neutrons to thermal energies is called a moderator.

The commonly used moderators are water, heavy water (D_2O) and graphite.

Class : 12th Physics
Chapter : 13 Nuclei

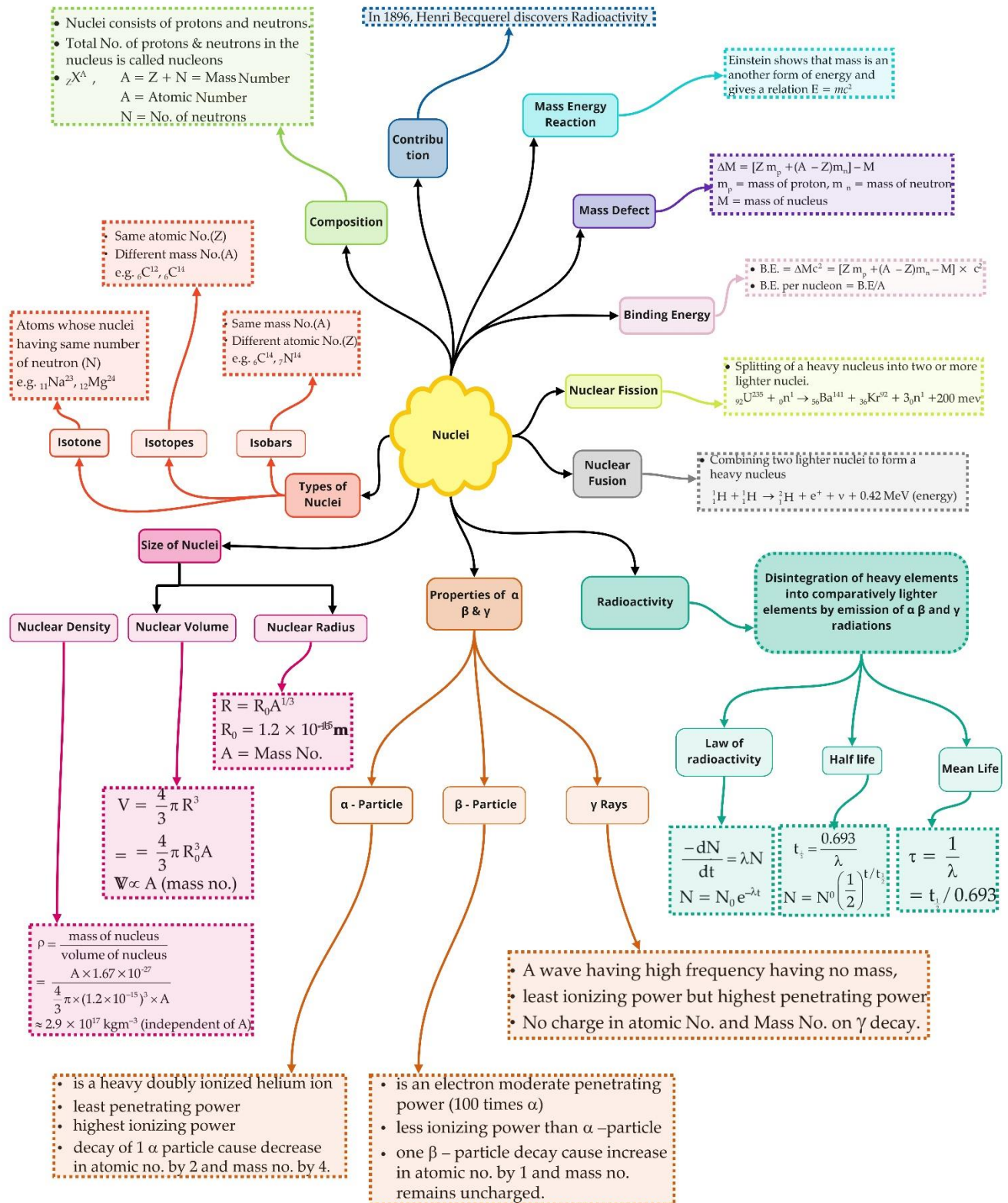

Important Questions

Multiple Choice questions-

Question 1. When a nucleus in an atom undergoes a radioactive decay, the electronic energy levels of the atom:

- (a) do not change for any type of radioactivity.
- (b) change for α and β radioactivity but not for γ -radioactivity.
- (c) change for α -radioactivity but not for others.
- (d) change for β -radioactivity but not for others.

Question 2. A radioactive isotope has a half-life of T years. The time it takes its activity to reduce to 3.125% is

- (a) 5 T
- (b) 6.654 T
- (c) 5.645 T
- (d) 6.654 T

Question 3. For a radioactive material, half-life is 10 minutes. If initially there are 600 number of nuclei, the time taken (in minutes) for the disintegration of 450 nuclei is:

- (a) 20
- (b) 10
- (c) 30
- (d) 15

Question 4. A nuclear explosive is designed to deliver 1 MW power in the form of heat energy. If the explosion is designed with nuclear fuel consisting of U^{235} to run a reactor at this power level for one year, then the amount of fuel needed is (given energy per fission is 200 MeV)

- (a) 1 kg
- (b) 0.01 kg
- (c) 3.84 kg
- (d) 0.384 kg

Question 5. When the radioactive isotope ${}_{88}\text{Ra}^{226}$ decays in a series by emission of three alpha (α) and a beta (β) particle, the isotope X which remains undecayed is

- (a) ${}_{83}\text{X}^{214}$
- (b) ${}_{84}\text{X}^{218}$
- (c) ${}_{84}\text{X}^{220}$
- (d) ${}_{87}\text{X}^{223}$

Question 6. Fusion reaction takes place, at high temperature because:

- (a) nuclei break up at high temperature
- (b) atoms get ionised at high temperature
- (c) kinetic energy is high enough to overcome the coulomb repulsion between nuclei
- (d) molecules break up at high temperature

Question 7. Half-lives of two radioactive elements A and B are 20 minutes and 40 minutes, respectively. Initially, the samples have equal number of nuclei. After 80 minutes, the ratio of decayed numbers of A and B nuclei will be:

- (a) 1 : 16
- (b) 4 : 1
- (c) 1 : 4
- (d) 5 : 4

Question 8. Radioactive material 'A' has decay constant ' 8λ ' and material 'B' has decay constant ' λ '. Initially they have same number of nuclei. After what time, the ratio of number of nuclei of material 'B' to that 'A' will be $1/e$?

- (a) $\frac{1}{7\lambda}$
- (b) $\frac{1}{8\lambda}$
- (c) $\frac{1}{9\lambda}$
- (d) $\frac{1}{\lambda}$

Question 9. A radioactive nucleus A with a half-life T decays into a nucleus B. At $t = 0$, there is no nucleus B. At some time, t the ratio of the number of B to that of A is 0.3. Then, t is given by:

- (a) $t = T \log(1.3)$
- (b) $t = \frac{T}{\log(1.3)}$
- (c) $t = \frac{T \log(2)}{2 \log(1.3)}$
- (d) $t = \frac{T \log(1.3)}{\log(2)}$

Very Short Answer Questions-

1. Complete the following nuclear reactions:

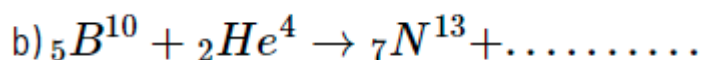
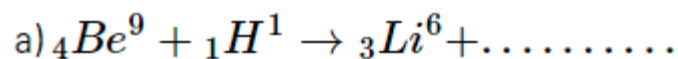

2. What is the Q-value of a nuclear reaction?

3. The wavelengths of some of the spectral lines obtained in hydrogen spectrum are 9546\AA , 6463\AA and 1216\AA . Which one of these wavelengths belongs to the Lyman series?
4. Write the empirical relation for paschen series lines of hydrogen atoms.
5. What will be the ratio of the radii of two nuclei of mass numbers A_1 and A_2 ?
6. Two nuclei have mass numbers in the ratio 1: 2. What is the ratio of their nuclear densities?
7. A nucleus of mass number A has a mass defect Δm . Give the formula, for the binding energy per nucleon of this nucleus.
8. Write the relation between half-life and decay constant of a radioactive sample.
9. Write the nuclear decay process for β -decay of ^{32}P .
10. State the relation between the mean life (τ) of a radioactive element and its decay constant λ .

Short Answer Questions-

Question 1. Draw the curve showing the binding energy/nucleon with a mass number of different nuclei. Briefly state, how nuclear fusion and nuclear fission can be explained on the basis of this graph.

Question 2. Define decay constant for a radioactive sample. Which of the following radiations α , β , and γ rays

- (i) are similar to X-rays,
- (ii) are easily absorbed by matter, and
- (iii) are similar in nature to cathode rays?

Question 3. State the law of radioactive decay.

Plot a graph showing the number of undecayed nuclei as a function of time (t) for a given radioactive sample having a half-life $T_{1/2}$.

Depict In the plot the number of undecayed nuclei at (i) $t = 3T_{1/2}$ and (ii) $t = 5 T_{1/2}$ (CBSE Delhi 2011)

Question 4. Draw a plot of the potential energy of a pair of nucleons as a function of their separations. Mark the regions where the nuclear force is (i) attractive and (ii) repulsive. Write any two characteristic features of nuclear forces. (CBSE AI 2012)

Question 5.

(a) Write the relation for binding energy (BE) (in MeV) of a nucleus of mass ${}_Z^A M$ atomic number (Z) and mass number (A) in terms of the masses of its constituents – neutrons and protons.

(b) Draw a plot of BE/A versus mass number A for $2 \leq A \leq 170$. Use this graph to explain the release of energy in the process of nuclear fusion of two light nuclei. (CBSE Delhi 2014C)

Question 6. If both the number of neutrons and the number of protons are conserved in each nuclear reaction, in what way is mass converted into energy (or vice versa) in a nuclear reaction? Explain. (CBSE AI2016C)

Question 7. State two properties of nuclear forces. Write the relation between half-life and decay constant of a radioactive nucleus. (CBSE AI 2017C)

Question 8.

(a) Draw a graph showing the variation of binding energy per nucleon (BE/A) vs mass number A for the nuclei in $20 \leq A \leq 170$.

(b) A nucleus of mass number 240 and having binding energy/nucleon 7.6 MeV splits into two fragments Y, 1 of mass numbers 110 and 130 respectively. If the binding energy/ nucleon of Y, 1 is equal to 8.5 MeV each, calculate the energy released in the nuclear reaction. (CBSE AI 2017C)

Question 9. Explain with the help of an example, whether the neutron-proton ratio in a nucleus increases or decreases due to beta decay.

Question 10. How is the size of a nucleus experimentally determined? Write the relation between the radius and mass number of the nucleus. Show that the density of the nucleus is independent of its mass number. (CBSE Delhi 2011C)

Long Answer's Questions-

1. The wavelength of the first member of the Balmer series in the hydrogen spectrum is 6563\AA . Calculate the wavelength of the first member of Lyman series in the same spectrum.

2. A neutron is absorbed by a ${}_3^6\text{Li}$ nucleus with subsequent emission of α -particle. Write the corresponding nuclear reaction. Calculate the energy released in this reaction. Given mass of ${}_3^6\text{Li}=6.015126\text{a.m.u.}$, Mass of ${}_2^4\text{He}=4.00026044\text{ a.m.u.}$, Mass of neutron ${}_0^1\text{n}=1.0086654\text{ a.m.u.}$ Mass of tritium ${}_1^3\text{H}=3.016049\text{ a.m.u.}$

3. Define decay constant of a radioactive sample. Which of the following radiation α -rays, β -rays and γ -rays.
- Are they similar to X – rays?
 - Are they easily absorbed by matter?
4. State radioactive decay law and hence derive the relation $N=N_0e^{-\lambda t}$ where symbols have their usual meanings.
5. Define half life and decay constant of a radioactive element. Write their S.I. unit. Define expression for half life.
6. Draw a curve between mass number and binding energy per nucleon. Give two salient features of the curve. Hence define binding energy.
- 7.
- Two stable isotopes of lithium ${}^6_3\text{Li}$ and ${}^7_3\text{Li}$ have respective abundances of 7.5 and 92.5 . These isotopes have masses 6.01512u and 7.01600u respectively. Find the atomic mass of lithium.
 - Boron has two stable isotopes, ${}^{10}_5\text{B}$ and ${}^{11}_5\text{B}$. Their respective masses are 10.01294u and 11.00931u , and the atomic mass of boron is 10.811u . Find the abundances of ${}^{10}_5\text{B}$ and ${}^{11}_5\text{B}$.
8. Obtain the binding energy of the nuclei ${}^{56}_{26}\text{Fe}$ and ${}^{209}_{83}\text{Bi}$ in units of MeV from the following data: $m({}^{56}_{26}\text{Fe})=55.934939\text{u}$, $m({}^{209}_{83}\text{Bi})=208.980388\text{u}$.

Assertion and Reason Questions-

1. For question, statements are given-one labelled Assertion (A) and the other labelled Reason (R). Select the correct answer to these questions from the codes (a) (b) (c) and (d) as given below.
- Both A and R are true, and R is the correct explanation of A.
 - Both A and R are true, but R is NOT the correct explanation of A.
 - A is true, but R is false.
 - A is false and R is also false.

Assertion (A): Thermonuclear fusion reactions may become the source of unlimited power for the mankind.

Reason (R): A single fusion event involving isotopes of hydrogen produces more energy than energy from nuclear fission of a single uranium.

2. For question, statements are given-one labelled Assertion (A) and the other labelled Reason (R). Select the correct answer to these questions from the codes (a) (b) (c) and (d) as given below.

- Both A and R are true, and R is the correct explanation of A.
- Both A and R are true, but R is NOT the correct explanation of A.
- A is true, but R is false.
- A is false and R is also false.

Assertion (A): A fission reaction can be more easily controlled than a fission reaction.

Reason (R): The percentage of mass converted to energy in a fission reaction is 0.1% whereas in a fusion reaction it is 0.4%

Case Study Questions-

1. When subatomic particles undergo reactions, energy is conserved, but mass is not necessarily conserved. However, a particle's mass “contributes” to its total energy, in accordance with Einstein's famous equation, $E = mc^2$. In this equation, E denotes the energy carried by a particle because of its mass. The particle can also have additional energy due to its motion and its interactions with other particles. Consider a neutron at rest and well separated from other particles. It decays into a proton, an electron and an undetected third particle as given here: Neutron \rightarrow proton + electron + ???

The given table summarizes some data from a single neutron decay. Electron volt is a unit of energy. Column 2 shows the rest mass of the particle times the speed of light squared.

Particle	Mass $\times c^2$ (MeV)	Kinetic energy (MeV)
Neutron	940.97	0.00
Proton	939.67	0.01
Electron	0.51	0.39

- (i) From the given table, which properties of the undetected third particle can be calculate?
- Total energy, but not kinetic energy.
 - Kinetic energy, but not total energy.
 - Both total energy and kinetic energy.
 - Neither total energy nor kinetic energy.

(ii) Assuming the table contains no major errors, what can we conclude about the (mass $\times c^2$) of the undetected third particle?

- a) It is 0.79 MeV
- b) It is 0.39 MeV
- c) It is less than or equal to 0.79 MeV; but we cannot be more precise.
- d) It is less than or equal to 0.40 MeV; but we cannot be more precise.

(iii) Could this reaction occur?

Proton \rightarrow neutron + other particles

- a) Yes, if the other particles have much more kinetic energy than mass energy.
- b) Yes, but only if the proton has potential energy (due to interactions with other particles).
- c) No, because a neutron is more massive than a proton.
- d) No, because a proton is positively charged while a neutron is electrically neutral.

(iv) How much mass has to be converted into energy to produce electric power of 500MW for one hour?

- a) 2×10^{-5} kg
- b) 1×10^{-5} kg
- c) 3×10^{-5} kg
- d) 4×10^{-5} kg

(v) The equivalent energy of 1g of substance is.

- a) 9×10^{13} J
- b) 6×10^{12} J
- c) 3×10^{13} J
- d) 6×10^{13} J

2. Neutrons and protons are identical particles in the sense that their masses are nearly the same and the force, called nuclear force, does not distinguish them. Nuclear force is the strongest force. Stability of nucleus is determined by the neutron proton ratio or mass defect or packing fraction. Shape of nucleus is calculated by quadrupole moment and spin of nucleus depends on even or odd mass number. Volume of nucleus depends on the mass number. Whole mass of the atom (nearly 99%) is centered at the nucleus.

(i) The correct statements about the nuclear force is/ are.

- a) Change independent.
 - b) Short range force.
 - c) Non-conservative force.
 - d) All of these.
- (ii) The range of nuclear force is the order of.
- a) $2 \times 10^{-10}\text{m}$
 - b) $1.5 \times 10^{-20}\text{m}$
 - c) $1.2 \times 10^{-4}\text{m}$
 - d) $1.4 \times 10^{-15}\text{m}$
- (iii) A force between two protons is same as the force between proton and neutron. The nature of the force is.
- a) Electrical force.
 - b) Weak nuclear force.
 - c) Gravitational force.
 - d) Strong nuclear force.
- (iv) Two protons are kept at a separation of 40 A. F_n is the nuclear force and F_e is the electrostatic force between them. Then.
- a) $F_n \ll F_e$
 - b) $F_n = F_e$
 - c) $F_n \gg F_e$
 - d) $F_n = F_e$
- (v) All the nucleons in an atom are held by.
- a) Nuclear forces
 - b) Van der Waal's forces
 - c) Tensor forces
 - d) Coulomb forces

Multiple Choice Question's Answers-

1. Answer: (b) change for α and β radioactivity but not for γ -radioactivity.
2. Answer: (a) 5 T
3. Answer: (a) 20
4. Answer: (d) 0.384 kg
5. Answer: (a) ${}_{83}\text{X}^{214}$

6. Answer: (c) kinetic energy is high enough to overcome the coulomb repulsion between nuclei
7. Answer: (d) 5 : 4
8. Answer: (a) $\frac{1}{7\lambda}$
9. Answer: (d) $t = \frac{T \log(1.3)}{\log(2)}$

Very Short Answers-

1. Ans: (a)

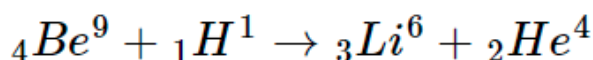

- Ans: (b)

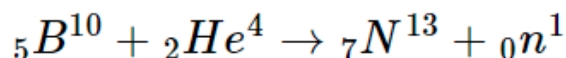

2. Ans: Q-value = (Mass of reactants – Mass of products)
3. Ans: 1216A° belong to the Lyman series.
4. Ans:

$$\frac{1}{\lambda} = R \left(\frac{1}{3^2} - \frac{1}{n^2} \right) \text{ where } n = 4, 5, 6, 7, \dots$$

5. Ans:

$$\text{The ratio is } \frac{R_1}{R_2} = \left(\frac{A_1}{A_2} \right)^{1/3}$$

6. Ans: The densities of both nuclei are equal as they do not depend upon mass number.
7. Ans:

$$\text{The formula is } E = \frac{\Delta m \times c^2}{A}$$

8. Ans:

$$\text{The relation is } T_{1/2} = \frac{0.693}{\lambda}$$

9. Ans:

The process is

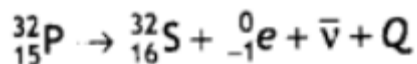

10. Ans:

The two are related as $\tau = 1 / \lambda$.

Short Answers -

1. Answer: The diagram is as shown.

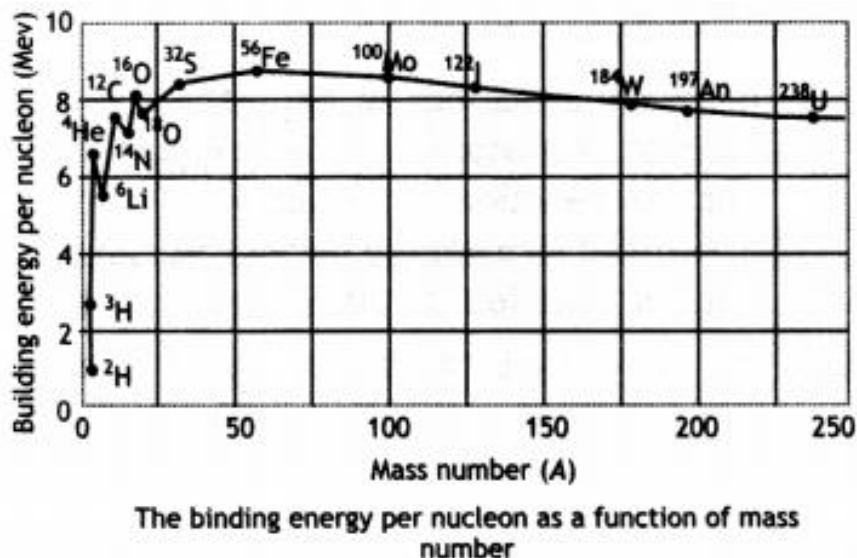

Light nuclei have a small value of binding energy per nucleon, therefore to become more stable they fuse to increase their binding energy per nucleon.

A very heavy nucleus, say A 240, has Lower binding energy per nucleon compared to that of a nucleus with A = 120. Thus if a nucleus A = 240 breaks into two A = 120 nuclei, nucleons get more tightly bound. This implies energy would be released in the process.

2. Answer: The decay constant is defined as the reciprocal of that time duration for which the number of nuclei of the radioactive sample decays to $1/e$ or 37 % of its original value.

- (i) Gamma
- (ii) Alpha
- (iii) Beta

3. Answer: The number of nuclei disintegrating per second is proportional to the number of nuclei present at the time of disintegration and is independent of all physical conditions like temperature, pressure, humidity, chemical composition, etc.

The plot is as shown.

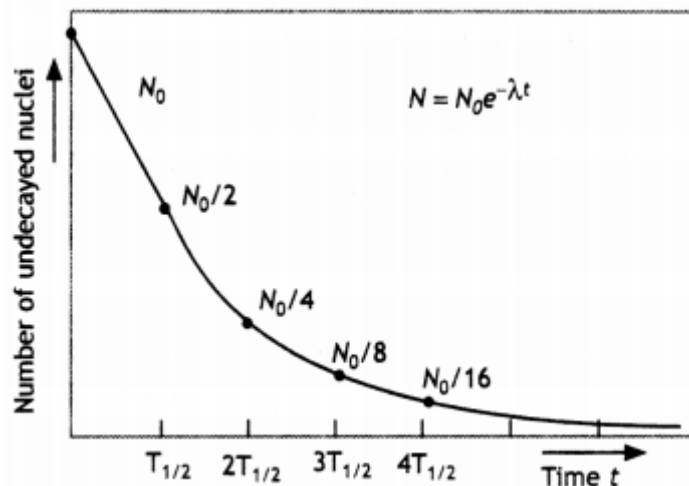

4. Answer:

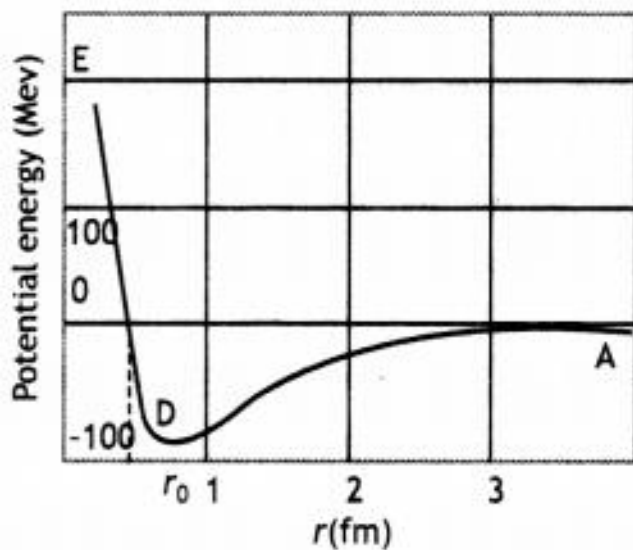

For $r > r_0$ (attraction), For $r < r_0$ (repulsion)

1. Strong attractive force (stronger than the repulsive electric force between the protons)
2. Are short-range forces.

5. Answer:

(a) The required expression is

$$\Delta E = (Zm_p + (A - Z)m_n - M) \times 931 \text{ MeV}$$

(b)

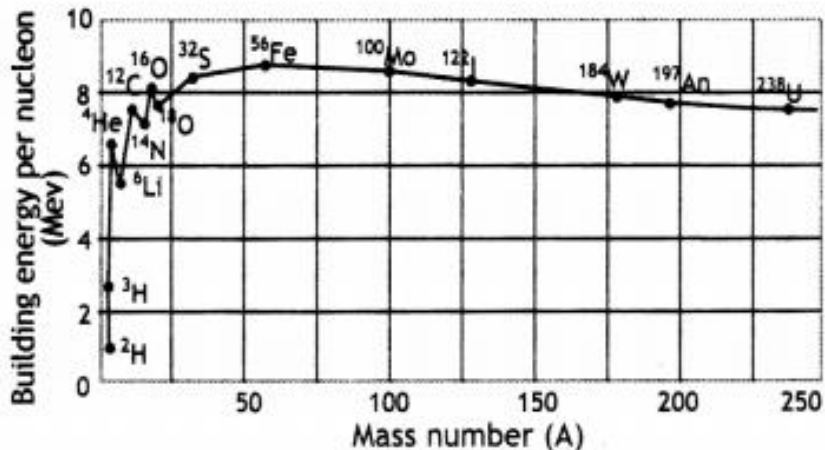

The binding energy per nucleon as a function of mass number

Since the binding energy of the smaller nuclei like hydrogen is less, therefore they fuse together to form helium in order to increase their binding energy per nucleon and become stable. This means that the final system is more tightly bound than the initial system. Again energy would be released in such a process of fusion.

6. Answer: We know that the binding energy of a nucleus gives a negative contribution to the mass of the nucleus (mass defect). Now, since proton number and neutron number are conserved in a nuclear reaction the total rest mass of neutrons and protons is the same on either side of a reaction. But the total binding energy of nuclei on the left side need not be the same as that on the right-hand side.

The difference in these binding energies appears as the energy released or absorbed in a nuclear reaction. Since binding energy contributes to mass, we say that the difference in the total mass of nuclei on the two sides gets converted into energy or vice-versa.

7. Answer:

- 1.They are saturated forces.
- 2.They are charge - independent.

The required relation is

$$T = \frac{\ln 2}{\lambda} = \frac{2.303 \log 2}{\lambda} = \frac{0.693}{\lambda}$$

8. Answer:

(a)

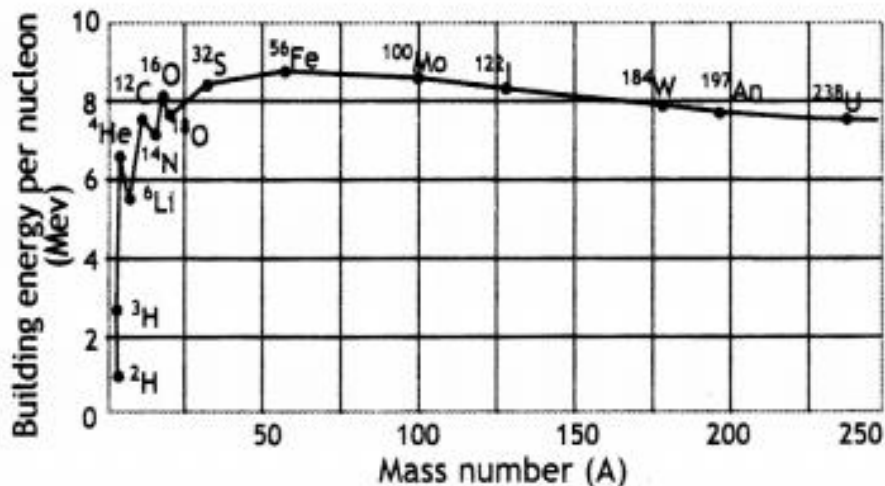

The binding energy per nucleon as a function of mass number

Since the binding energy of the smaller nuclei like hydrogen is less, therefore they fuse together to form helium in order to increase their binding energy per nucleon and become stable. This means that the final system is more tightly bound than the initial system. Again energy would be released in such a process of fusion.

(B) Energy released per fission

$$= (110 + 130) \times 8.5 - 240 \times 7.6$$

$$= 240 \times (8.5 - 7.6) \text{ MeV}$$

$$= 240 \times 0.9$$

$$= 216.0 \text{ MeV}$$

9. Answer:

Consider the following decay

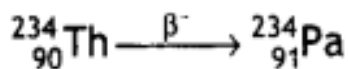

Number of neutrons before beta decay

$$= 234 - 90 = 144$$

Number of neutrons after beta decay

$$= 234 - 91 = 143$$

Number of protons before beta decay

$$= 90$$

Number of protons after beta decay

$$= 91$$

Neutron-proton ratio before beta decay

$$= \frac{144}{90} = 1.6$$

Neutron-proton ratio after beta decay

$$= \frac{143}{91} = 1.57$$

Thus neutron-proton ratio decreases during beta decay.

10. Answer: The size of the nucleus can be determined by the Rutherford experiments on alpha particles scattering. The distance of the nearest approach is approximately the size of the nucleus. Here it is assumed that only coulomb repulsive force caused scattering. With alpha rays of 5.5 MeV, the size of the nucleus was found to be less than 4×10^{-14} m. By doing scattering experiments with fast electrons bombarding targets of different elements, the size of the nuclei of various elements determined accurately.

The required relation is

$$R = R_0 A^{1/3}, \text{ where } R_0 = 1.2 \times 10^{-15} \text{ m}$$

The density of a nucleus of mass number A and radius R is given by

$$\begin{aligned} \text{Nuclear density} &= \frac{\text{Mass of nucleus}}{\text{Volume of the nucleus}} \\ &= \frac{A \text{ amu}}{\frac{4}{3} \pi R^3} = \frac{A \times 1.660565 \times 10^{-27}}{\frac{4}{3} \pi R_0^3 A} \\ &= 2.3 \times 10^{17} \text{ kg m}^{-3} \end{aligned}$$

which is independent of the mass number A.

Long Answers-

1. Ans: It is known that,

$$\frac{1}{\lambda} = R \left(\frac{1}{2^2} - \frac{1}{n_i^2} \right), n = 3, 4, 5, \dots$$

For first member $n_i = 3$ (Balmer series)

$$\Rightarrow \frac{1}{\lambda_1} = R \left(\frac{1}{2^2} - \frac{1}{3^2} \right)$$

$$\Rightarrow \frac{1}{\lambda_1} = R \left(\frac{1}{4} - \frac{1}{9} \right)$$

$$\Rightarrow \lambda_1 = \frac{36}{5R} \dots\dots(1)$$

For first member of Lyman series

$$\Rightarrow \frac{1}{\lambda_1'} = R \left(\frac{1}{1^2} - \frac{1}{2^2} \right)$$

$$\Rightarrow \frac{1}{\lambda_1'} = R \left(1 - \frac{1}{4} \right)$$

$$\Rightarrow \lambda_1' = \frac{4}{3R} \dots\dots(2)$$

From (1) and (2)

$$\Rightarrow \frac{\lambda_1'}{\lambda_1} = \frac{4}{3R} \times \frac{5R}{36}$$

$$\Rightarrow \lambda_1' = \frac{5}{27} \lambda_1$$

$$\Rightarrow \lambda_1' = \frac{5}{27} \times 6563$$

$$\Rightarrow \lambda_1' = 1215.4 \text{ \AA}$$

Therefore, the wavelength of the first member of the Lyman series is **1215.4 \AA**.

2. Ans:

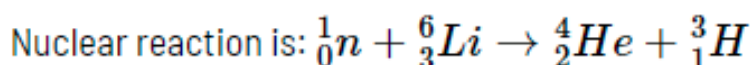

$$\text{Mass of reactants} = m({}_0^1n) + m({}_3^6\text{Li}) =$$

$$\Rightarrow \text{Mass} = 1.0086654 + 6.015126 = 7.0237914 \text{ a.m.u}$$

Mass Defect, $\Delta m = \text{mass of reactant} - \text{mass of product}$

$$\Rightarrow \Delta m = 7.02371947 - 0.01818513 = 7.00553434$$

$$\Rightarrow \Delta m = 0.005138 \text{ a.m.u.}$$

It is known that, $1 \text{ a.m.u.} = 931 \text{ MeV}$

Energy released, $E = \Delta m \times 931 \text{ MeV}$

$$\Rightarrow E = 0.005138 \times 931$$

$$\Rightarrow E = 4.783 \text{ MeV}$$

3. Ans:

(a) Radioactive decay constant (λ) is the reciprocal of time during which the number of atoms in the radioactive substance is reduced to 36.8% of the original number of atoms in it.

γ -rays are similar to X-rays.

(b) Penetration power of α -rays is less than that of β -rays and γ -rays.
So γ -rays are easily absorbed by matter.

4. Ans: From the radioactive decay law, the rate of disintegration of a radioactive substance at an instant is directly proportional to the number of nuclei in the radioactive substance at that time i.e.

$N = N_0 e^{-\lambda t}$ where symbols have their usual meanings

Consider a radioactive substance having N_0 atoms initially at time ($t=0$). After time (t), let the number of atoms left undecayed be N .

If dN is the number of atoms decayed in time dt , then

$$\text{From the law of radioactive decay: } \frac{-dN}{dt} \propto N \text{ or } \frac{-dN}{dt} = \lambda N \dots\dots(1)$$

Where,

λ is the decay constant and negative sign indicates that a radioactive sample goes on decreasing with time.

$$(1) \Rightarrow \frac{dN}{N} = -\lambda dt$$

Integrating both the sides

$$\log_e N = -\lambda t + K \dots\dots(2)$$

Where K is constant of integration

$$\text{For } t = 0, N = N_0$$

$$\Rightarrow K = \log_e N_0$$

Substituting K in equation (2)

$$\Rightarrow \log_e N = -\lambda t + \log_e N_0$$

$$\Rightarrow \log_e N - \log_e N_0 = -\lambda t \left[\log_e m - \log_e n = \log_e \left(\frac{m}{n} \right) \right]$$

$$\Rightarrow \log_e \left(\frac{N}{N_0} \right) = -\lambda t$$

$$\Rightarrow \frac{N}{N_0} = e^{-\lambda t}$$

$$\Rightarrow N = N_0 e^{-\lambda t}$$

Hence derived.

5. Ans: The time during which half of the atoms of the radioactive substance disintegrate is called half life of a radioactive substance.

It is known that, $N = N_0 e^{-\lambda t}$

If $t = T_{1/2}$ (Half life), $N = \frac{N_0}{2}$

$$\Rightarrow \frac{N_0}{2} = N_0 e^{-\lambda T_{1/2}}$$

$$\Rightarrow \frac{1}{2} = e^{-\lambda T_{1/2}}$$

$$\Rightarrow e^{\lambda T_{1/2}} = 2$$

$$\Rightarrow \lambda T_{1/2} = \log_e 2$$

$$\Rightarrow \lambda T_{1/2} = 2.303 \times \log_{10} 2$$

$$\Rightarrow \lambda T_{1/2} = 2.303 \times 0.3010$$

$$\Rightarrow T_{1/2} = \frac{0.6931}{\lambda}$$

S.I. unit - *second* (s)

Radioactive decay constant(λ) is the reciprocal of the time during which the number of atoms in the radioactive substance reduces to 36.8% of the original number of atoms in it.

S.I. unit – s^{-1} or min^{-1}

6. Ans: The total energy required to disintegrate the nucleus into its constituent particles is called binding energy of the nucleus.

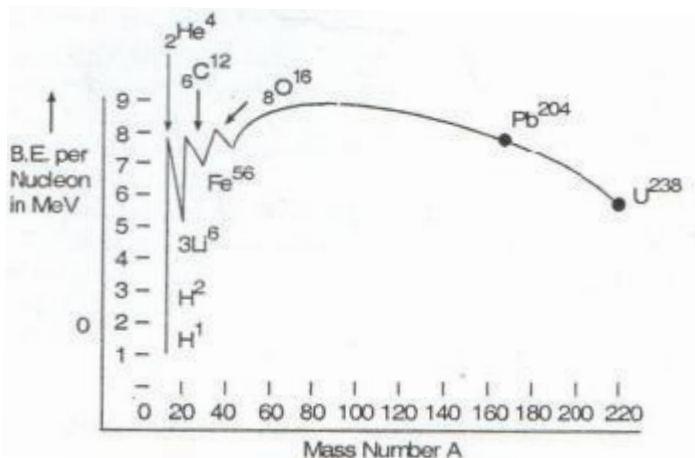

Salient features of the curve

(i) The intermediate nuclei have a large value of binding energy per nucleon, so they are most stable. (For $30 < A < 63$)

(ii) The binding energy per nucleon has low value for both the light and heavy nuclei. So, they are unstable nuclei.

7. Ans: (a) Given that,

Mass of lithium isotope ${}^6_3\text{Li}$, $m_1 = 6.01512 u$

Mass of lithium isotope ${}^7_3\text{Li}$, $m_2 = 7.01600 u$

Abundance of ${}^6_3\text{Li}$, $\eta_1 = 7.5$

Abundance of ${}^7_3\text{Li}$, $\eta_2 = 92.5$

The atomic mass of lithium atom, $m = \frac{m_1\eta_1 + m_2\eta_2}{\eta_1 + \eta_2}$

$$\Rightarrow m = \frac{6.0512 \times 7.5 + 7.01600 \times 92.5}{7.5 + 92.5}$$

$$\Rightarrow m = 6.940934u$$

Therefore, the atomic mass of lithium is $6.940934u$.

(b) It is given that,

Mass of boron isotope 1_5B , $m_1 = 10.01294u$

Mass of boron isotope ${}^{11}_5B$, $m_2 = 11.00931u$

Abundance of 1_5B , $\eta_1 = x$

Abundance of ${}^{11}_5B$, $\eta_2 = (100 - x)$

Atomic mass of boron, $m = 10.811u$

The atomic mass of boron atom, $m = \frac{m_1\eta_1 + m_2\eta_2}{\eta_1 + \eta_2}$

$$\Rightarrow 10.811 = \frac{10.01294 \times x + 11.00931 \times (100 - x)}{x + 100 - x}$$

$$\Rightarrow 108.11 = 10.01294x + 1100.931 - 11.00931x$$

$$\Rightarrow x = \frac{19.821}{0.99637} = 19.89$$

$$\Rightarrow 100 - x = 80.11$$

Therefore, the abundance of 1_5B is 19.89 and abundance of ${}^{11}_5B$ is 80.11.

8. Ans. Given that,

Atomic mass of ${}^{56}_{26}\text{Fe}$, $m_1 = 55.934939u$

${}^{56}_{26}\text{Fe}$ nucleus has 26 protons and $(56 - 26) = 30$ neutrons

Therefore, the mass defect of the nucleus, $\Delta m = 26 \times m_H + 30 \times m_n - m_1$

Where,

Mass of proton, $m_H = 1.007825u$

Mass of a neutron, $m_n = 1.008665u$

$$\Rightarrow \Delta m = 26 \times 1.007825 + 30 \times 1.008665 - 55.934939$$

$$\Rightarrow \Delta m = 26.20345 + 30.25995 - 55.934939$$

$$\Rightarrow \Delta m = 0.528461u$$

It is known that, $1u = 931.5 \frac{\text{MeV}}{c^2}$

The binding energy of this nucleus is $E_{b_1} = \Delta mc^2$

c is the speed of light

$$\Rightarrow E_{b_1} = 0.528461 \times 931.5 \left(\frac{\text{MeV}}{c^2} \right) \times c^2$$

$$\Rightarrow E_{b_1} = 492.26 \text{ MeV}$$

$$\text{Average binding energy per nucleon} = \frac{492.26}{56} = 8.79 \text{ MeV}$$

Atomic mass of ${}_{83}^{209}\text{Bi}$, $m_2 = 208.980388u$

${}_{83}^{209}\text{Bi}$ nucleus has 83 protons and $(209 - 83) = 126$ neutrons.

Therefore, the mass defect of this nucleus, $\Delta m' = 83 \times m_H + 126 \times m_n - m_2$

Where,

Mass of proton, $m_H = 1.007825u$

Mass of a neutron, $m_n = 1.008665u$

$$\Rightarrow \Delta m' = 83 \times 1.007825 + 126 \times 1.008665 - 208.980388$$

$$\Rightarrow \Delta m' = 83.649475 + 127.091790 - 208.980388$$

$$\Rightarrow \Delta m' = 1.760877u$$

It is known that, $1u = 931.5 \frac{\text{MeV}}{c^2}$

The binding energy of this nucleus is $E_{b_2} = \Delta m' c^2$

Where,

c is the speed of light

$$\Rightarrow E_{b_2} = 1.760877 \times 931.5 \left(\frac{\text{MeV}}{c^2} \right) \times c^2$$

$$\Rightarrow E_{b_2} = 1640.26 \text{ MeV}$$

$$\text{Clearly, average binding energy per nucleon} = \frac{1640}{209} = 7.848 \text{ MeV}$$

Assertion and Reason Answers-

1. (c) A is true, but R is false.

Explanation:

When fusion is achieved by raising the temperature of the system so that particles have enough kinetic energy to overcome the coulomb repulsive behaviour, it is called thermonuclear fusion. It is clean source of energy, but energy released in one fusion is much less than a single uranium fission.

2. Both A and R are true, but R is NOT the correct explanation of A.

Explanation:

Percentage of mass converted to energy in a fission reaction is 0.1% whereas in a fusion reaction it is 0.4%. Consequently, the amount of energy released is more in a fusion than in a fission reaction. It is not easy to control a fusion reaction.

Case Study Answers-

1. Answer :

(i) (a) Total energy, but not kinetic energy.

Explanation:

As just shown, energy conservation allows us to calculate the third particle's total energy. But we do not know what percentage of that total is mass energy.

(ii) (d) It is less than or equal to 0.40 MeV, but we cannot be more precise.

Explanation:

According to the passage, subatomic reactions do not conserve mass. So, we cannot find the third particle's mass by setting m_{neutron} equal to-

$$m_{\text{proton}} + m_{\text{electron}} + E_{\text{third particle}}$$

The neutron has energy 940.97 MeV. The proton has energy 939.67 MeV + 0.01 MeV = 939.69 MeV. The electron has energy 0.51 MeV + 0.39 MeV = 0.90 MeV. Therefore, the third particle has energy.

$$E_{\text{third particle}} = E_{\text{neutron}} - E_{\text{proton}} - E_{\text{electron}}$$

$$= 940.97 - 939.67 - 0.90 = 0.40 \text{ MeV}$$

We just found the third particle's total energy, the sum of its mass energy and kinetic energy. Without more information, we cannot figure out how much of that energy is mass energy.

(iii) (b) Yes, but only if the proton has potential energy (due to interactions with other particles).

(iv) (a) $2 \times 10^{-5} \text{ kg}$

Explanation:

Here, $P = 500 \text{ MW} = 5 \times 10^8 \text{ W}$,

$t = 1 \text{ h} = 3600 \text{ s}$

Energy produced, $E = P \times t = 5 \times 10^8 \times 3600 = 18 \times 10^{11} \text{ J}$

$$\text{As } E = \Delta mc^2$$

$$\therefore \Delta m = \frac{E}{c^2} = \frac{18 \times 10^{11}}{(3 \times 10^8)^2}$$

$$= \frac{18 \times 10^{11}}{(3 \times 10^8)^2} = 2 \times 10^{-5} \text{ kg}$$

(v) (a) $9 \times 10^{13} \text{ J}$

Explanation:

Using, $E = mc^2$

Here, $m = 1 \text{ g} = 1 \times 10^{-3} \text{ kg}$, $c = 3 \times 10^8 \text{ m s}^{-1}$

$$\therefore E = 10^{-3} \times 9 \times 10^{16} = 9 \times 10^{13} \text{ J}$$

2. Answer :

(i) (d) All of these.

Explanation:

All options are basic properties of nuclear forces. So, all options are correct.

(ii) (d) $1.4 \times 10^{-15} \text{m}$

Explanation:

The nuclear force is of short range and the range of nuclear force is the order of $1.4 \times 10^{-15} \text{m}$. Now, volume $\propto R^3 \propto A$

(iii) (d) Strong nuclear force.

(iv) (a) $F_n \ll F_e$

Explanation:

Nuclear force is much stronger than the electrostatic force inside the nucleus i.e., at distances of the order of fermi. At 40 A, nuclear force is ineffective and only electrostatic force of repulsion is present. This is very high at this distance because nuclear force is not acting now and the gravitational force is very feeble. $F_{\text{nuclear}} \ll F_{\text{electrostatic}}$ in this case.

(v) (a) Nuclear forces



C V RAMAN
P U C O L L E G E
INDI

CHAPTER 14: SEMICONDUCTOR ELECTRONICS

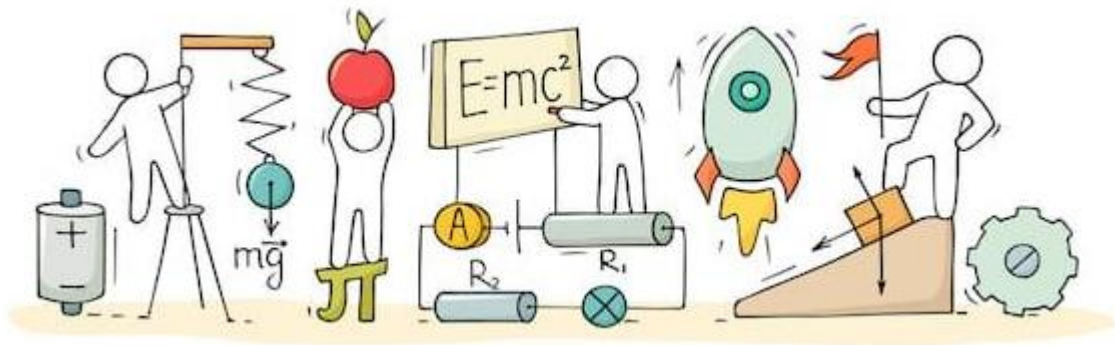

SEMICONDUCTOR ELECTRONICS

Classification of Metals:

On the basis of the relative values of electrical conductivity (σ) or resistivity ($\rho = \frac{1}{\sigma}$), the solids are broadly classified as:

Metals:

They possess very low resistivity (or high conductivity).

$$\rho \sim 10^{-2} - 10^{-8} \Omega \text{ m}$$

$$\sigma \sim 10^2 - 10^8 \text{ S m}^{-1}$$

Semiconductors:

They have resistivity or conductivity intermediate to metals and insulators.

$$\rho \sim 10^{-5} - 10^6 \Omega \text{ m}$$

$$\sigma \sim 10^5 - 10^6 \text{ S m}^{-1}$$

Insulators:

They have high resistivity (or low conductivity).

$$\rho \sim 10^{11} - 10^{19} \Omega \text{ m}$$

$$\sigma \sim 10^{-11} - 10^{-19} \text{ S m}^{-1}$$

Classification of Metals on the Basis of Energy Bands:

When the atoms come together to form a solid they are so close to each other that the fields of electrons of outer orbits from neighboring atoms overlap. This makes the nature of electron motion in a solid very different from that in an isolated atom. Inside the solid, each electron has a unique position, and no two electrons have same pattern of surrounding charges.

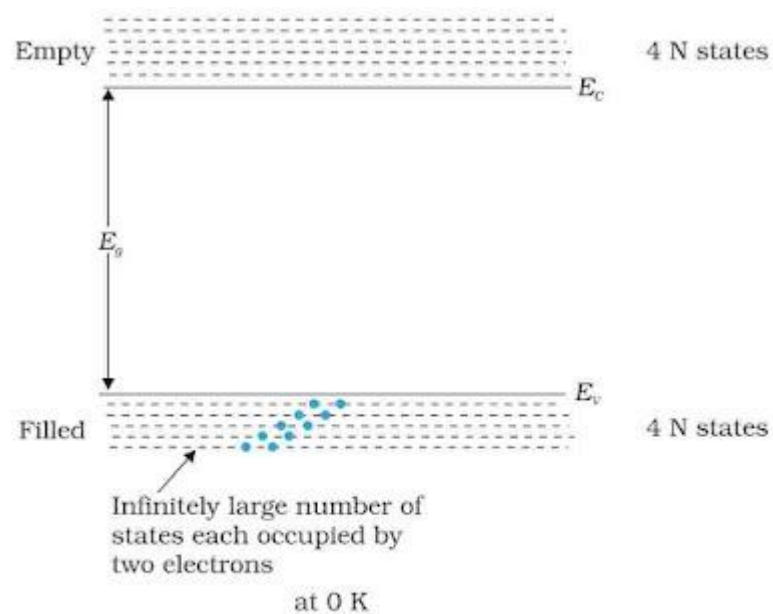

Metals:

In metals, conduction band and valence band are overlapped to each other. The electrons from the valence band can easily move into the conduction band. Normally, the conduction band is empty but when it overlaps on the valence band, electrons can move freely into it, and it conducts electric current through it.

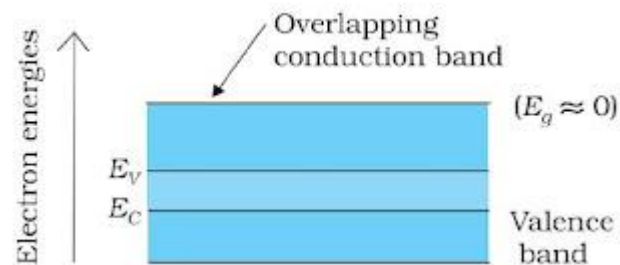

Semiconductors:

Semiconductors are the core fundamental materials which are used in solid-state electronic devices such as transistors, diodes etc. The material's atomic structure decides whether the material will turn out to be a metal, semiconductor, or insulator. Semiconductors could also be elements such as Ge, Si or compounds such as CdS or GaAs.

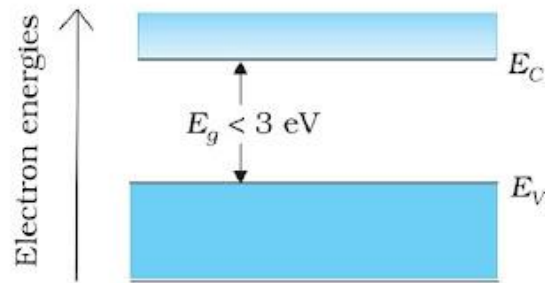

Insulators:

In semiconductors, a small and finite energy band gap exists. Because of the small energy band gap some electrons from valence band, at room temperature, acquire enough energy to cross the energy gap and enter the conduction band. These electrons are very few and can move in the conduction band. Hence, the resistance of semiconductors is not as high as that of the insulators.

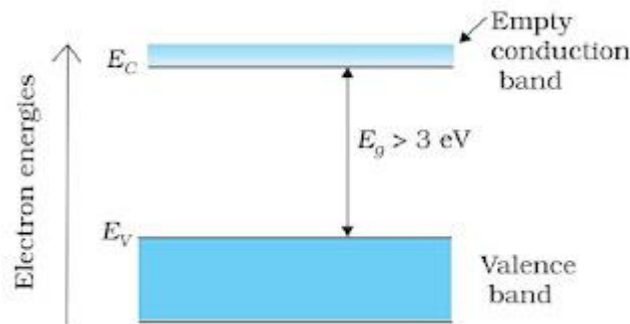

Intrinsic Semiconductor:

The pure semiconductors in which the electrical conductivity is totally governed by the electrons excited from the valence band to the conduction band and in which no impurity atoms are added to increase their conductivity are called intrinsic semiconductors and their conductivity is called intrinsic conductivity. Electrical conduction in pure semiconductors occurs by means of electron-hole pairs. In an intrinsic semiconductor,

$$n_e = n_h = n_i$$

where n_e = the free electron density in conduction band, n_h = the hole density in valence band, and n_i = the intrinsic carrier concentration.

Extrinsic Semiconductors:

A Semiconductor doped with suitable impurity atoms so as to increase its conductivity is called an extrinsic semiconductor.

Types of Semiconductor:

Extrinsic semiconductors are basically of two types:

n-type semiconductors:

The pentavalent impurity atoms are called donors because they donate electrons to the host crystal and the semiconductor doped with donors is called n-type semiconductor. In n-type semiconductors, electrons are the majority charge carriers and holes are the minority charge carriers. Thus, $n_e \gg n_h$

p-type semiconductors:

The trivalent impurity atoms are called acceptors because they create holes which can accept electrons from the nearby bonds. A semiconductor doped with acceptor type impurities is called a p-type semiconductor. In p-type semiconductor, holes are the majority carriers and electrons are the minority charge carriers Thus,

$$n_h \gg n_e$$

Diode:

Diodes are being for the purpose of AC voltage rectification which means restricting the voltage to follow one direction only using a capacitor or a filter, a dc voltage can be achieved.

The types of diodes are:

Zener Diode: This is used in places where voltage regulation is needed.

P-N junction diode: It is used in photonic or optoelectronic devices and the entity is the photon. Examples are solar cells, light-emitting diodes etc.

Holes:

The vacancy or absence of electron in the bond of a covalently bonded crystal is called a hole. A hole serves as a positive charge carrier.

p-n Junction Formation:

In the n-region of a p-n junction, the concentration of free electrons is higher than that of holes, whereas in the p-region, the concentration of holes is much higher than that of free electrons. Therefore, when a p-n junction is formed, some electrons from the n-region will diffuse into the p-region. Since the hole is nothing but the vacancy of an electron, an electron diffusing from the n- to the p-region simply fills this vacancy, i.e., it completes the covalent bond. This process is called electron-hole

recombination.

Semiconductor Diode:

A semiconductor diode is basically a p-n junction with metallic contacts provided at the ends for the application of an external voltage. The symbol for the simplest electronic device, namely the p-n junction is shown as. The direction of the thick arrow is from the p to the n-region. The p-side is called the anode and the n-side is known as the cathode.

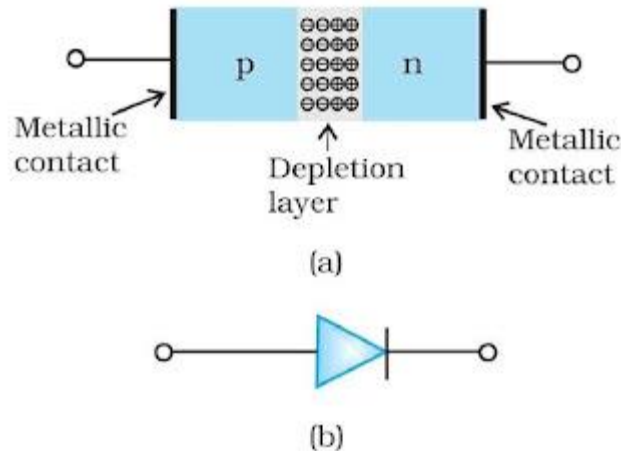

Forward Biasing of a pn-junction:

If the positive terminal of a battery is connected to the p-side and the negative terminal to the n-side, then the pn-junction is said to be forward biased. Both electrons and holes move towards the junction. A current, called forward current, flows across the junction. Thus, a pn-junction offers a low resistance when it is forward biased.

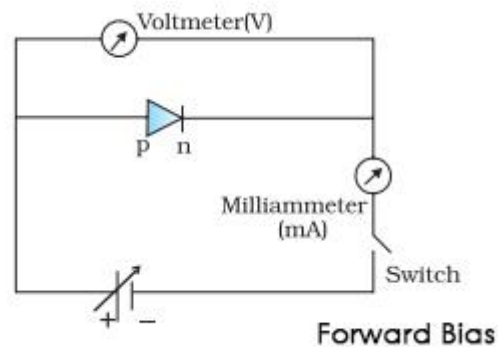

Reverse Biasing of a pn-junction:

If the positive terminal of a battery is connected to the n-side and negative terminal to the p-side, then pn-junction is said to be reverse biased. The majority charge carriers move away from the junction. The potential barrier offers high resistance during the

reverse bias. However, due to the minority charge carriers a small current, called reverse or leakage current flows in the opposite direction. Thus, junction diode has almost a unidirectional flow of current.

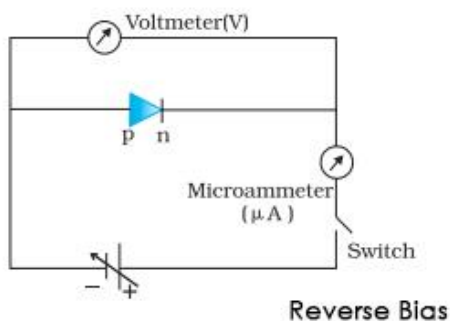

Characteristics of Junction Diode:

With increasing forward bias, the current first increases non-linearly up to a certain forward-biased voltage called knee voltage or cut-in voltage and beyond which the current varies non-linearly.

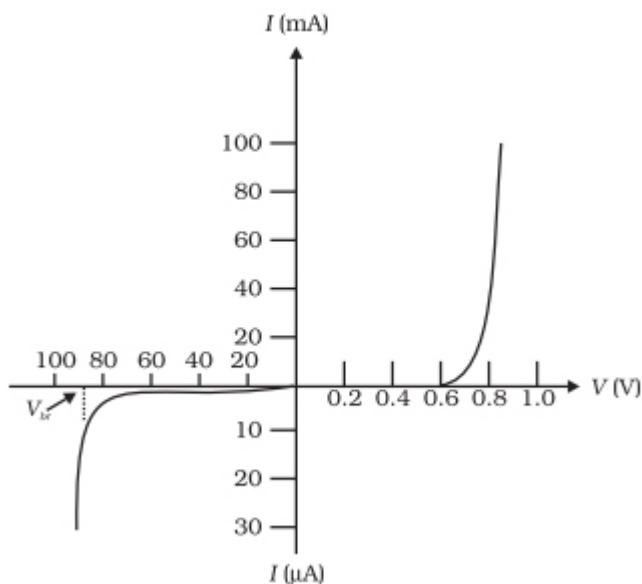

Diode as Rectifier:

The process of converting alternating voltage/ current into direct voltage/ current is called rectification. Diode is used as a rectifier for converting alternating current/ voltage into direct current/ voltage.

There are two ways of using a diode as a rectifier i.e.

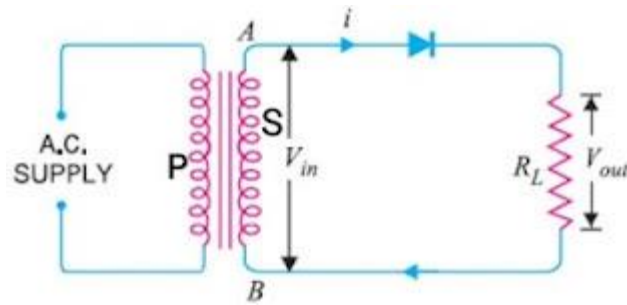

Half-wave Rectifier:

Let during the first half of AC input cycle, the end A of secondary S of transformer be at positive potential and end B at the negative potential. In this situation, the diode is forward biased and a current flow in the circuit. Consequently, an output voltage across load R_L is obtained.

During the second half of AC input, the end A of secondary S of transformer is at negative potential and diode D is in reverse bias. So, no current flows through load R_L and there is no output voltage across R_L .



In the next positive half-cycle of AC input, we again get the output and so on. Thus, we get output voltage as shown in Fig. Here, the output voltage, though still varying in magnitude, is restricted to only one direction, and is said to be rectified. Since, the rectified output of the circuit is obtained only for half of the input AC wave, the device is called half-wave rectifier.

Full-wave rectifier:

During the first half cycle of the input voltage, the terminal A is positive with respect to O while B is negative with respect to O. Diode first is forward bias and conducts while diode second is reverse bias and does not conduct, the current flow through RL from D To O. During the second half cycle, A is negative, and B is positive with respect to O, thus diode first is reverse bias and diode second is forward biased. The current through RL is in the same direction as during the first half cycle. The resulting output current is a continuous series.

As we are getting output in positive half as well as negative half of AC input cycle, the

rectifier is called a full wave rectifier. Obviously, this is a more efficient circuit for getting rectified voltage or current than a half wave rectifier.

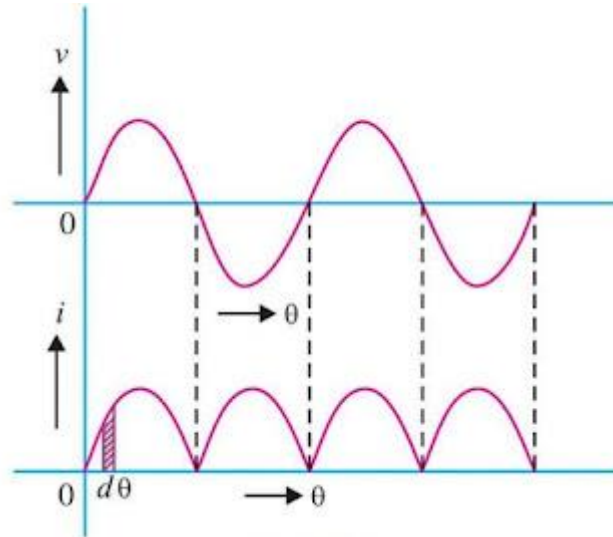

Zener diode:

The specially designed junction diodes which can operate in the reverse breakdown voltage region continuously without being damaged, are called Zener diodes.



Photodiode:

A junction diode made from photosensitive semiconductor is called a photodiode. In photodiode one region is made so thin that incident light may reach the depletion region.

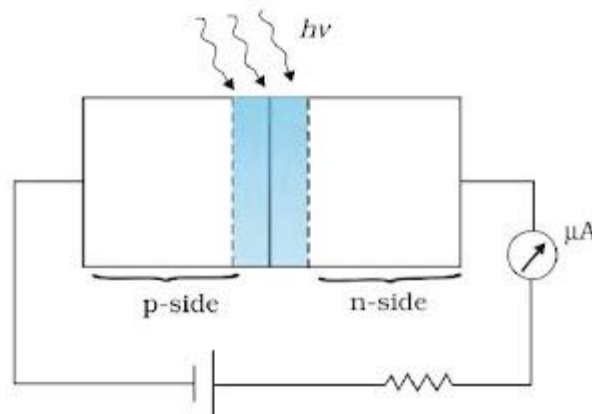

Light-Emitting Diode (LED):

Light-emitting diode is a heavily doped p-n junction encapsulated with a transparent cover so that emitted light can come out. When the forward current of the diode is small the intensity of light emitted is small. As the forward current increases, intensity of light increases and reaches a maximum.

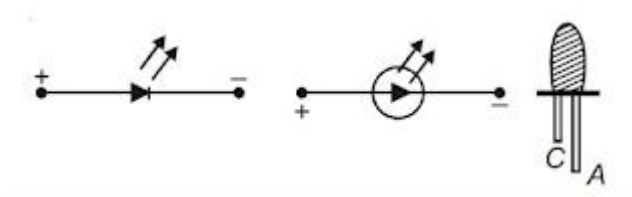

Solar cell:

In a solar cell, one region is made very thin so that most of the light incident on it reaches the depletion region. In this diode when photons of visible light incident to depletion region, electrons jump from valence band to conduction band producing electron-hole pairs.

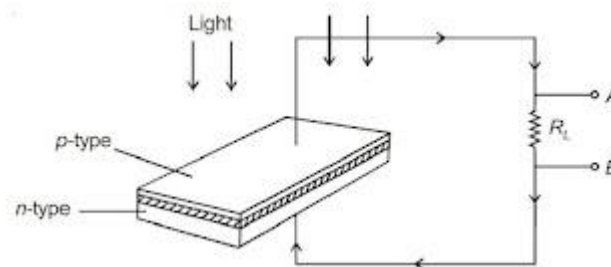

Action of a transistor:

When the emitter-base junction of an n-p-n-transistor is forward biased, the electrons are pushed towards the base. As the base region is very thin and lightly doped, most of the electrons cross over to the reverse biased collector. Since few electrons and holes always recombine in the base region, so the collector current I_C is always slightly less than emitter current I_E .

$$I_E = I_C + I_B$$

Where I_B is the base current.

Digital Electronics and Logic Gates:

There are three basic logic gates:

(i) OR gate (ii) AND gate, and (iii) NOT gate.

NOT Gate:

This is the most basic gate, with one input and one output. It produces an inverted version of the input at its output i.e., it produces a '1' output if the input is '0' and vice versa. This is why it is also known as an inverter.

AND gate:

An AND gate can have any number of inputs but only one output. It gives a high output (1) if inputs A and B are both high (1), or else the output is low (0). It is described by the Boolean expression.

$$A.B = Y$$

Which is read as 'A and B equals Y.'

Combination of Gates:**The NAND gate:**

If the output 'Y' of AND gate is connected to the input of NOT gate, the gate so obtained is called NAND gate. Boolean expression for the NAND gate is $Y = \overline{A.B}$

The NOR gate:

If the output ('Y') of OR gate is connected to the input of a NOT gate, the gate so obtained is called the NOR gate. Boolean expression for the NOR gate is $Y = \overline{A + B}$.

Integrated Circuits:

The concept of fabricating an entire circuit (consisting of many passive components like R and C and active devices like diode and transistor) on a small single block (or chip) of a semiconductor has revolutionized the electronics technology. Such a circuit is known as Integrated Circuit (IC).

Class : 12th Physics
Chapter- 14 : Semiconductor Electronics Materials, Devices & Simple Circuits

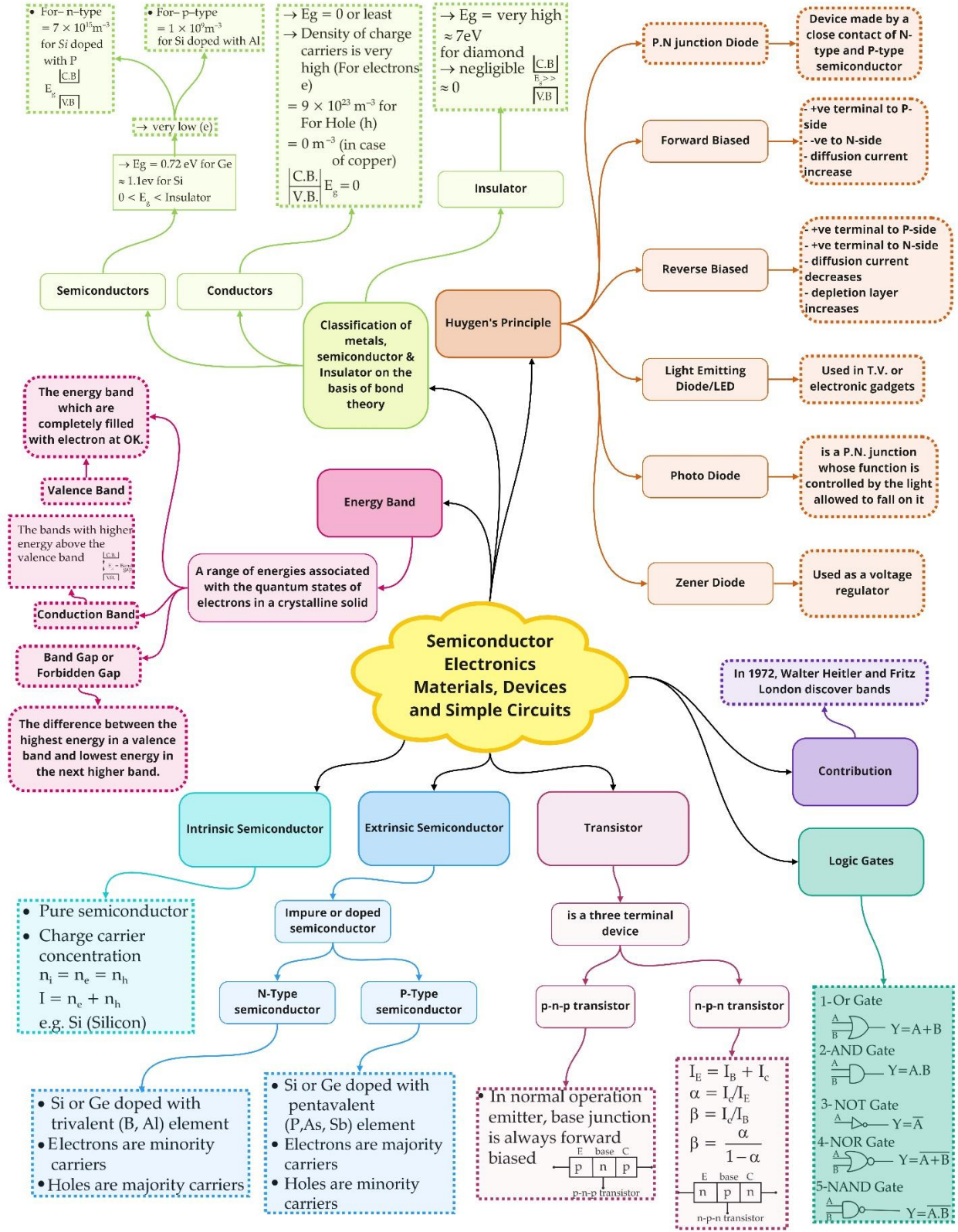

Important Questions

Multiple Choice questions-

1. In the figure, assuming the diodes to be ideal,

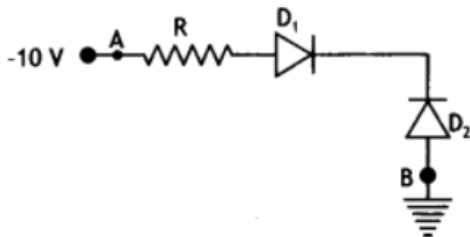

- A. D_1 is forward biased and D_2 is reverse biased and hence current flows from A to B.
- B. D_2 is forward biased and D_1 is reverse biased and hence no current flows from B to A and vice versa.
- C. D_1 and D_2 are both forward biased and hence current flows from A to B.
- D. D_1 and D_2 are both reverse biased and hence no current flows from A to B and vice versa.
2. Hole is:
- A. an anti-particle of electron.
- B. a vacancy created when an electron leaves a covalent bond.
- C. absence of free electrons.
- D. an artificially created particle.
3. For the depletion region of a diode which one is incorrect?
- A. There are no mobile charges.
- B. Equal number of holes and electrons exists, making the region neutral.
- C. Recombination of holes and electrons has taken place.
- D. Immobile charged ions exist.
4. To reduce the ripples in a rectifier circuit with capacitor filter which one is false?
- A. R_L should be increased.
- B. Input frequency should be decreased.
- C. Input frequency should be increased.
- D. Capacitors with high capacitance should be used.

5. Carbon, silicon and germanium have four valence electrons each. These are characterised by valence and conduction bands separated by energy band gap respectively equal to $(E_g)_C$, $(E_g)_{Si}$ and $(E_g)_{Ge}$. Which of the following statements is true?
- A. $(E_g)_{Si} < (E_g)_{Ge} < (E_g)_C$
 - B. $(E_g)_C < (E_g)_{Ge} > (E_g)_{Si}$
 - C. $(E_g)_C > (E_g)_{Si} > (E_g)_{Ge}$
 - D. $(E_g)_C = (E_g)_{Si} = (E_g)_{Ge}$
6. In an unbiased p-n junction, holes diffuse from the p-region to n-region because:
- A. free electrons in the n-region attract them.
 - B. they move across the junction by the potential difference.
 - C. hole concentration in p-region is more as compared to n-region.
 - D. All the above.
7. In a p-n junction diode, change in temperature due to heating:
- A. affects only reverse resistance
 - B. affects only forward resistance
 - C. Does not affect resistance of p-n junction
 - D. affects the overall V-I characteristics of p-n junction
8. A specimen of silicon is to be made p-type semiconductor for this one atom of indium, on an average, is doped in 5×10^7 silicon atoms. If the number density of silicon is 5×10^{22} atoms m^{-3} , then the number of acceptor atoms per cm^3 will be:
- A. 2.5×10^{30}
 - B. 1.0×10^{13}
 - C. 1.0×10^{15}
 - D. 2.5×10^{36}
9. The given circuit has two ideal diodes connected as shown in the figure below. The current flowing through the resistance R_1 will be:

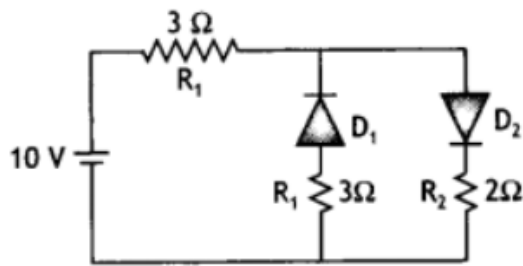

- A. 1.43 A
- B. 3.13 A
- C. 2.5 A
- D. 10.0 A

10. Consider the junction diode as ideal. The value of current flowing through AB is:

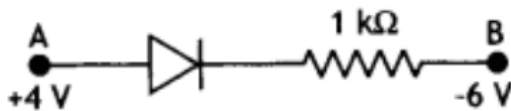

- A. 0 A
- B. 10^{-2} A
- C. 10^{-1} A
- D. 10^{-3} A

Very Short Questions:

1. Give the ratio of number of holes and the number of conduction electrons in an intrinsic semiconductor.
2. What type of impurity is added to obtain n-type semiconductor?
3. Doping of silicon with indium leads to which type of semiconductor?
4. Draw an energy level diagram for an intrinsic semiconductor.
5. A semiconductor has equal electron and hole concentration of $6 \times 10^8 \text{ m}^{-3}$. On doping with a certain impurity electron concentration increases to $3 \times 10^{12} \text{ m}^{-3}$. Identify the type of semiconductor after doping.
6. How does the energy gap of an intrinsic semiconductor vary, when doped with a trivalent impurity?
7. How does the width of the depletion layer of p-n-junction diode change with decrease in reverse bias?
8. Under what condition does a junction diode work as an open switch?

9. Which type of biasing gives a semiconductor diode very high resistance?
10. If the output of a 2-input NAND gate is fed as the input to a NOT gate,
 - a) name the new logic gate obtained and
 - b) write down its truth table

Short Questions :

1. If the frequency of the input signal is f . What will be the frequency of the pulsating output signal in case of :
 - (i) half wave rectifier?
 - (ii) full wave rectifier?
2. Find the equivalent resistance of the network shown in figure between point A and B when the p-n junction diode is ideal and :
 - (i) A is at higher potential
 - (ii) B is at higher potential

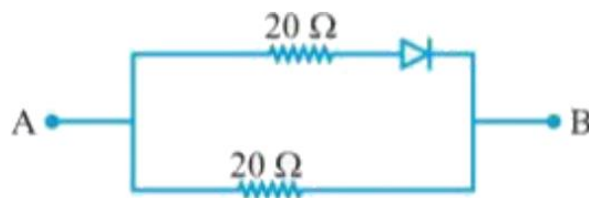

3. Potential barrier of p.n. junction cannot be measured by connecting a sensitive voltmeter across its terminals. Why?
4. The diagram shows a piece of pure semiconductor S in series with a variable resistor R and a source of constant voltage V. Would you increase or decrease the value of R to keep the reading of ammeter A constant, when semiconductor S is heated? Give reason.

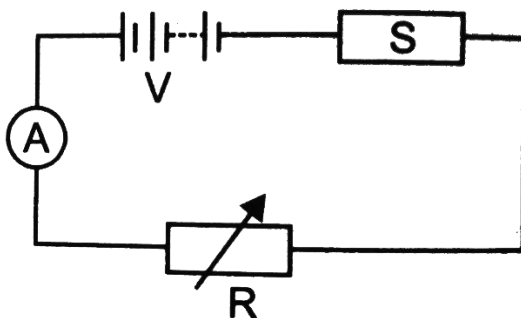

5. Why is a photo diode used in reverse bias?
6. What is an ideal diode? Draw the output wave form across the load resistor R, if the input waveform is as shown in the figure.

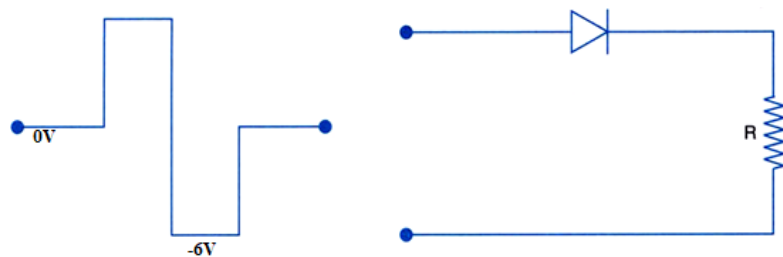

7. With the help of a labeled circuit diagram, explain full wave rectification using junction diode. Draw input and output wave forms?
8. Name the gate shown in the figure and write its truth table?

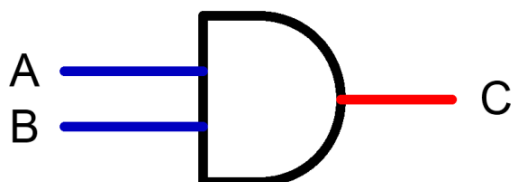

9. In the following diagrams indicate which of the diodes are forward biased and which are reverse bias?

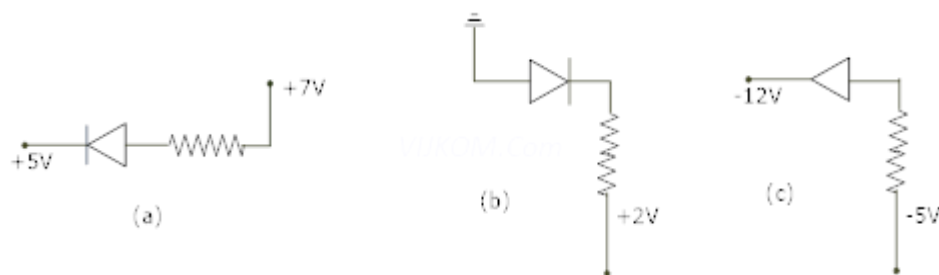

10. In the given figure, is
- The emitter base
 - collector base forward or reverse biased? Justify.

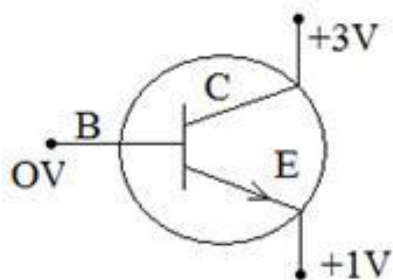

(i)

Long Answers Q.:

- Distinguish between conductors, insulators and semiconductors on the basis of energy band diagrams?
- The following truth table gives the output of a 2-input logic gate.

3.

A	B	Output
0	0	1
0	1	0
1	0	0
1	1	0

Identify the logic gate used and draw its logic symbol. If the output of this gate is fed as input to a NOT gate, name the new logic gate so formed?

4. With the help of a diagram, show the biasing of a light emitting diode (LED). Give its two advantages over conventional incandescent lamps?
5. The input resistance of a silicon transistor is 665Ω . Its base current is changed by $15\mu A$, which results in the change in collector current by $2mA$. This transistor is used as a common emitter amplifier with a load resistance of $5k\Omega$. Calculate current gain (β_{ac}).
6. Draw the symbol for zener diode? Zener diodes have higher dopant densities as compared to ordinary p-n junction diodes. How does it affect the (i) width of the depletion layer (ii) junction field?
7. A P-N-P transistor is used in common – emitter mode in an amplifier circuit. A change of $40\mu A$ in the base current brings a change of $2mA$ in collector current and $0.04V$ in base – emitter voltage. Find (i) input resistance (ii) current amplification factor (β). If a load resistance of $6k\Omega$ is used, then find voltage gain?
8. A semiconductor has equal electron and hole concentration of $6 \times 10^8 / m^3$. On doping with certain impurity, electron concentration increases to $8 \times 10^{12} / m^3$.
 - (i) Identify the new semiconductor
 - (ii) Calculate the new hole concentration.
 - (iii) How does the energy gap vary with doping?
9. Draw a labeled circuit diagram of a common emitter transistor amplifier. Draw the input and the output wave forms and also state the relation between input and output signal?

10. In an intrinsic semiconductor the energy gap E_g is 1.2 eV. Its hole mobility is much smaller than electron mobility and independent of temperature. What is the ratio between conductivity at 600K and that at 300K? Assume that the temperature dependence of intrinsic carrier concentration n_i is given by

$$n_i = n_0 \exp\left[-\frac{E_g}{2k_B T}\right]$$

where n_0 is a constant.

11. In a p-n junction diode, the current I can be expressed as

$$I = I_0 \exp\left(\frac{eV}{2k_B T} - 1\right)$$

where I_0 is called the reverse saturation current, V is the voltage across the diode and is positive for forward bias and negative for reverse bias, and I is the current through the diode, k is the Boltzmann constant (8.6×10^{-5} eV/K) and T is the absolute temperature. If for a given diode $I_0 = 5 \times 10^{-12}$ A and $T = 300$ K, then

- What will be the forward current at a forward voltage of 0.6 V?
- What will be the increase in the current if the voltage across the diode is increased to 0.7 V?
- What is the dynamic resistance?
- What will be the current if reverse bias voltage changes from 1 V to 2 V?

Assertion and Reason Questions –

1. Two statements are given—one labelled Assertion (A) and the other labelled Reason (R). Select the correct answer to these questions from the codes (a), (b), (c) and (d) as given below.

- Both A and R are true and R is the correct explanation of A.
- Both A and R are true but R is not the correct explanation of A.
- A is true but R is false.
- A is false and R is also false.

Assertion: The ratio of free electrons to holes in intrinsic semiconductor is greater than one.

Reason: The electrons are lighter particles and holes are heavy particles.

2. Two statements are given-one labelled Assertion (A) and the other labelled Reason (R). Select the correct answer to these questions from the codes(a), (b), (c) and (d) as given below.

- Both A and R are true and R is the correct explanation of A.
- Both A and R are true but R is not the correct explanation of A.
- A is true but R is false.
- A is false and R is also false.

Assertion: : The half-wave rectifier work only for positive half cycle of ac.

Reason: In half-wave rectifier only one diode is used.

Case Study Questions –

1. Solar cell is a p-n junction diode which converts solar energy into electric energy. It is basically a solar energy converter. The upper layer of solar cell is of p-type semiconductor and very thin so that the incident light photons may easily reach the p-n junction. On the top face of p-layer, the metal finger electrodes are prepared in order to have enough spacing between the fingers for the lights to reach the p-n junction through p-layer.

(i) The schematic symbol of solar cell is:

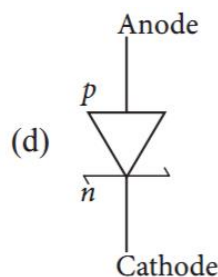
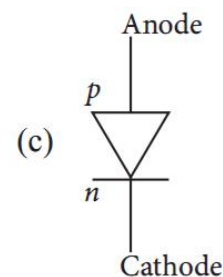
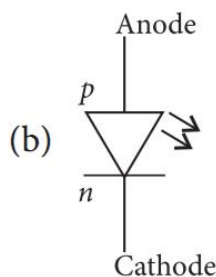
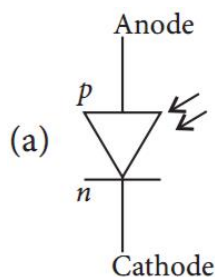

(ii) The p-n junction which generates an emf when solar radiations fall on it, with no external bias applied, is a:

- Light emitting diode.
- Photodiode.
- Solar cell.
- None of these.

(iii) For satellites the source of energy is:

- Solar cell.
- Fuel cell.
- Edison cell.
- None of these.

(iv) Which of the following material is used in solar cell?

- a) Barium.
- b) Silicon.
- c) Silver.
- d) Selenium.

(v) The efficiency of a solar cell may be in the range:

- a) 2 to 5%
- b) 10 to 15%
- c) 30 to 40%
- d) 70 to 80%

2. P-n junction is a single crystal of Ge or Si doped in such a manner that one half portion of it acts as p-type semiconductor and other half functions as n-type semiconductor. As soon as a p-n junction is formed, the holes from the p-region diffuse into n-region, and electron from n region diffuse in p-region. This results in the development of V_b across the junction which opposes the further diffusion of electrons and holes through the junction.

(i) In an unbiased p-n junction electrons diffuse from n-region to p-region because:

- a) Holes in p-region attract them.
- b) Electrons travel across the junction due to potential difference.
- c) Electron concentration in n-region is more as compared to that in p-region.
- d) Only electrons move from n to p region and not the vice-versa.

(ii) Electron hole recombination in p-n junction may lead to emission of:

- a) Light.
- b) Ultraviolet rays.
- c) Sound.
- d) Radioactive rays.

(iii) In an unbiased p-n junction:

- a) Potential at p is equal to that at n.
- b) Potential at p is + ve and that at n is - ve.
- c) Potential at p is more than that at n.
- d) Potential at p is less than that at n.

(iv) The potential of depletion layer is due to:

- a) Electrons.
- b) Holes.
- c) Ions.

- d) Forbidden band.
- (v) In the depletion layer of unbiased p-n junction,
- It is devoid of charge carriers.
 - Has only electrons.
 - Has only holes.
 - P-n junction has a weak electric field.

Multiple Choice question's Answers –

- D2 is forward biased and D1 is reverse biased and hence no current flows from B to A and vice versa.
- a vacancy created when an electron leaves a covalent bond.
- There are no mobile charges.
- Input frequency should be decreased.
- $(E_g)_C > (E_g)_{Si} > (E_g)_{Ge}$
- hole concentration in p-region is more as compared to n-region.
- affects the overall V-I characteristics of p-n junction
- 1.0×10^{15}
- 2.5 A
- 10-2A

Very Short Answers :

- $\frac{n_h}{n_e} = 1$ (In intrinsic semiconductor, $n_e = n_h$).
- Pentavalent atoms (group -15) like Phosphorus (P), Arsenic (As), etc.
- Doping of Silicon with Indium produces a p-type semiconductor as Indium is a trivalent impurity.
- In intrinsic semiconductor, $n_e = n_h$

The energy level diagram for an intrinsic semiconductor is shown below:

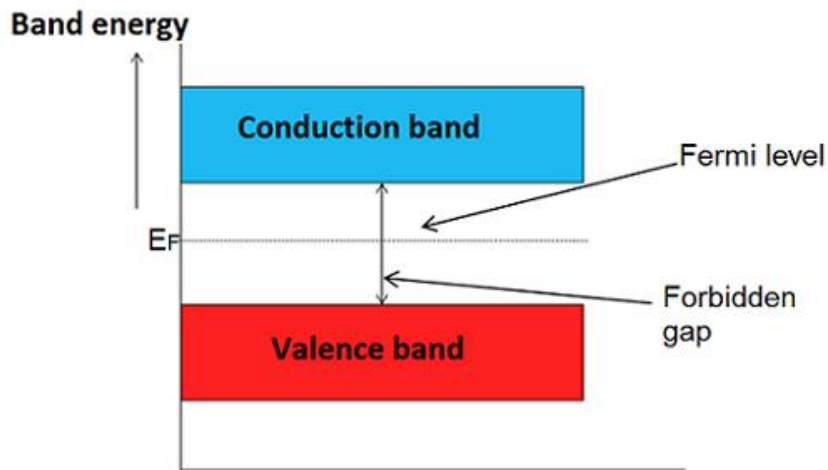

5. According to the question, after doping, $n_e > n_h$.
Clearly, we get an n-type semiconductor after doping.
6. An acceptor energy level is formed in the forbidden energy gap above the valence band when an intrinsic semiconductor is doped with a trivalent impurity.
Due to this, electrons quickly jump to the acceptor energy level.
7. The width of the depletion layer will decrease with decrease in reverse bias.
8. A junction diode works as an open switch when it is connected under reverse bias conditions.
9. Reverse biasing gives a semiconductor diode very high resistance.
10.
 - a) An AND gate is obtained when the output of a 2-input NAND gate is fed as the input to a NOT gate.
 - b) Truth table for an AND gate is given below.

A	B	Y
0	0	0
0	1	0
1	0	0

1	1	1
---	---	---

Short Answers:

1. Frequency of output in half wave Rectifier is f and in full wave rectifier is $2f$.
2. Equivalent resistance is
 - (i) 10Ω
 - (ii) 20Ω
3. Because there is no free charge carrier in depletion region.
4. On heating S , resistance of semiconductors S is decreased so to compensate the value of resistance in the circuit R is increased.
5. In this case diode is sensitive and it gives very large amount of current in this situation.
6. An ideal diode has zero resistance when forward biased and an infinite resistance when it is reverse biased. Output wave from is:

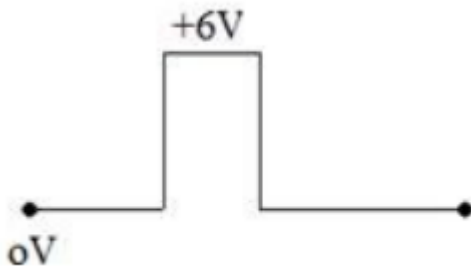

7. Full wave rectifier consists of two diodes and a transformer with central tap. For any half cycle of a.c. input only one diode is forward biased where as the other one is reverse biased.

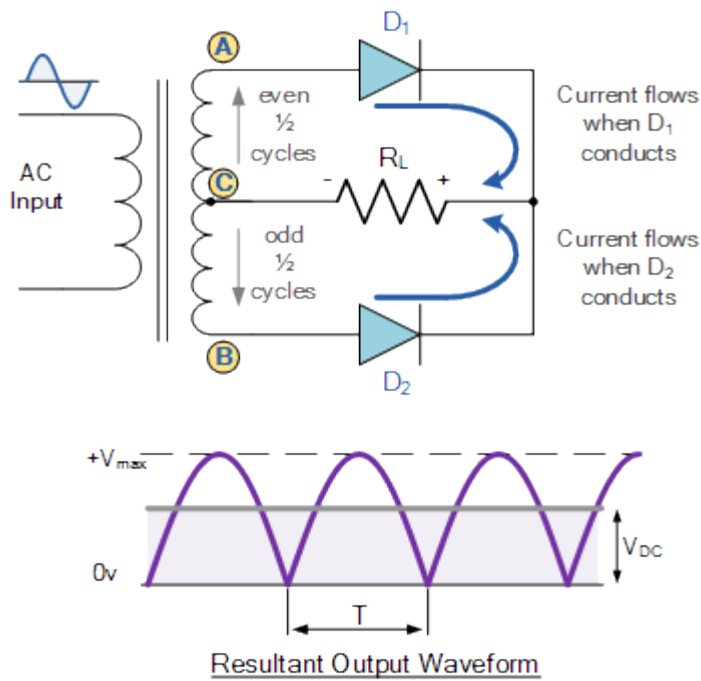

Suppose for positive half of a.c. input diode D_1 is forward biased and D_2 is reverse biased, then the current will flow across D_1 where as for negative half of a.c. input diode D_2 is forward biased and the current flows across D_2 . Thus for both the halves output is obtained and current flows in the same direction across load resistance R_2 and thus a.c. is converted into d.c.

8. It is AND gate and its truth table is:

Input		Output
A	B	$Y=A.B$
0	0	0
0	1	0
1	0	0
1	1	1

- 9. (a) Forward Biased
- (b) Reverse Biased
- (c) forward Biased

10. Figure shows n-p-n transistor

- (ii) Emitter is reversed biased because n-region is connected to higher potential.
- (iii) Collector is also reversed biased because n-region of p-n junction is at higher potential than p-region.

Long Answers:

1.

Conductor – Conduction band in a conductor is either partially filled or conduction and valence band overlaps each other. There is no energy gap in a conductor.

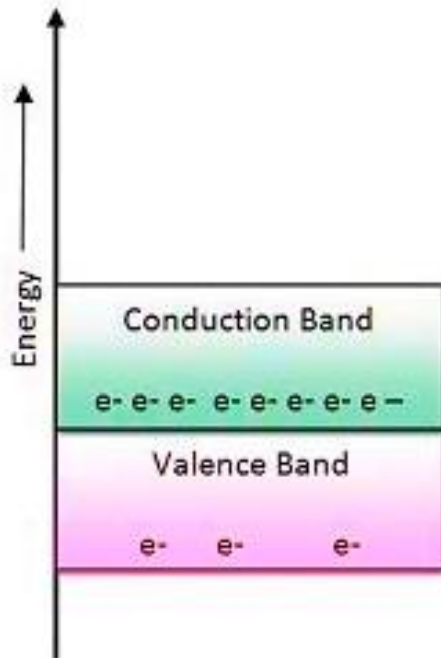

Conductors

Insulators – conduction band and valence band of all insulator are widely separated by an energy gap of the order 6 to 9eV. Also, the conduction band of an insulator is almost empty.

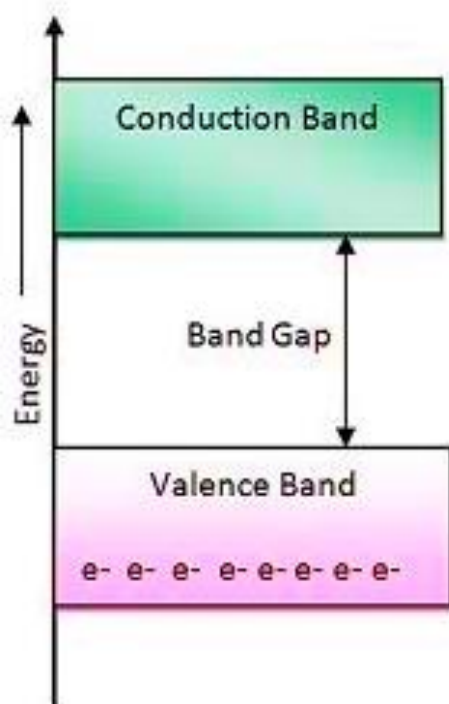

Insulators

Semiconductor – In semiconductors the energy gap is very small i.e. about 1ev only.

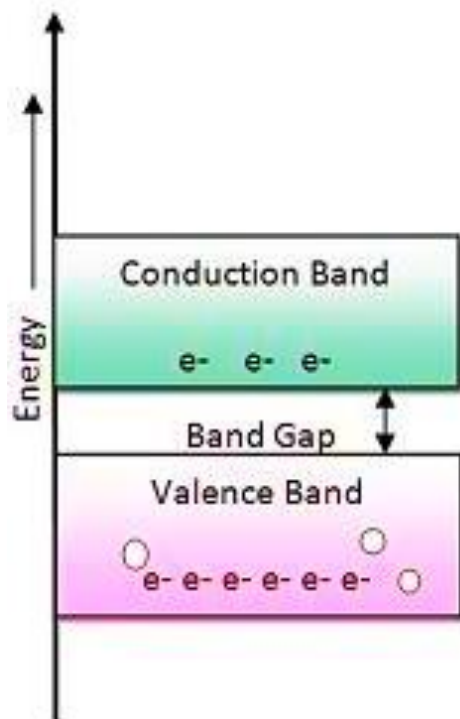

Semiconductors

- The gate is NOR gate. If the output of NOR gate is connected to a NOT

gathen the figure will be:

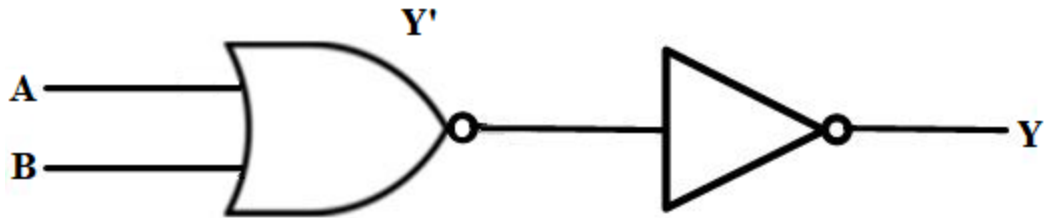

New truth table is:

A	B	Output
0	0	0
0	1	1
1	0	1
1	1	1

3. Light emitting diode is forward biased i.e. energy is released at the junction.

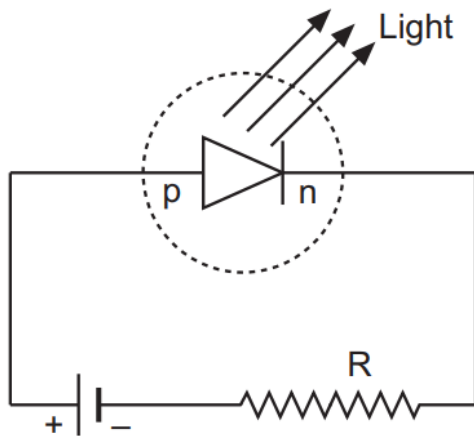

Advantages of LED

- 1) They are used in numerical displays as compact in size.
 - 2) It works at low voltage and has longer life than incandescent bulbs.
- 4.
- (1) Trans conductance (gm) (2) voltage gain (Av) of the amplifier.

$$\text{Here } \Delta I_B = 15 \mu A = 15 \times 10^{-6} A$$

$$\Delta I_C = 2 mA = 2 \times 10^{-3} A$$

$$R_{in} = 665 \Omega, R_2 = 5 k\Omega = 5 \times 10^3 \Omega$$

$$\beta_{ac} = \frac{\Delta I_C}{\Delta I_B} = \frac{2 \times 10^{-3}}{15 \times 10^{-6}} = 133.3$$

$$(1) \text{ Trans conductance, } g_m = \frac{\beta_{ac}}{R_{in}} = \frac{133.3}{665} = 0.2 \Omega^{-1}$$

$$(2) \text{ Voltage gain (Av)} = g_m R_L = 0.2 \times 5 \times 10^3 = 1000$$

5. Symbol for zener diode

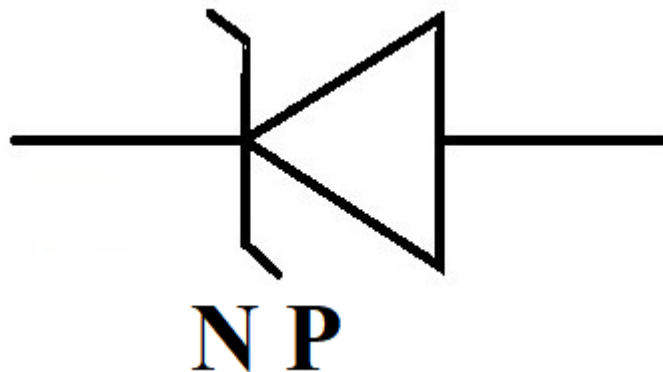

(i) Width of the depletion layer of zener diode becomes very small due to heavy doping of p and n-regions

(ii) Junction field will be high..

6. Ans:

$$\Delta I_B = 40 \mu A = 40 \times 10^{-6} A$$

$$\Delta I_C = 2 mA = 2 \times 10^{-3} A$$

$$\Delta V_{BE} = 0.04 V$$

$$R_L = 6 k\Omega = 6 \times 10^3 \Omega$$

$$R_{in} = \frac{\Delta V_{BE}}{\Delta I_B} = \frac{0.04}{40 \times 10^{-6}} = 1 \times 10^3 \Omega = 1 k\Omega$$

$$\beta = \frac{\Delta v_C}{\Delta I_B} = \frac{2 \times 10^{-3}}{40 \times 10^{-6}} = 50$$

$$\text{Voltage gain} = \beta \frac{R_L}{R_i} = \frac{50 \times 6 \times 10^3}{1 \times 10^3} = 300$$

7.

- (i) New semiconductor obtained is N-type because
 (ii) $nenh = ne^2$

$$nh = \frac{ni^2}{ne} = \frac{36 \times 10^{15}}{8 \times 10^{12}}$$

$$nh = 4.5 \times 10^4 / m^3$$

- (ii) Energy gap decreases due to creation of donor level in between the valence band and the conduction band.

8. Diagram:

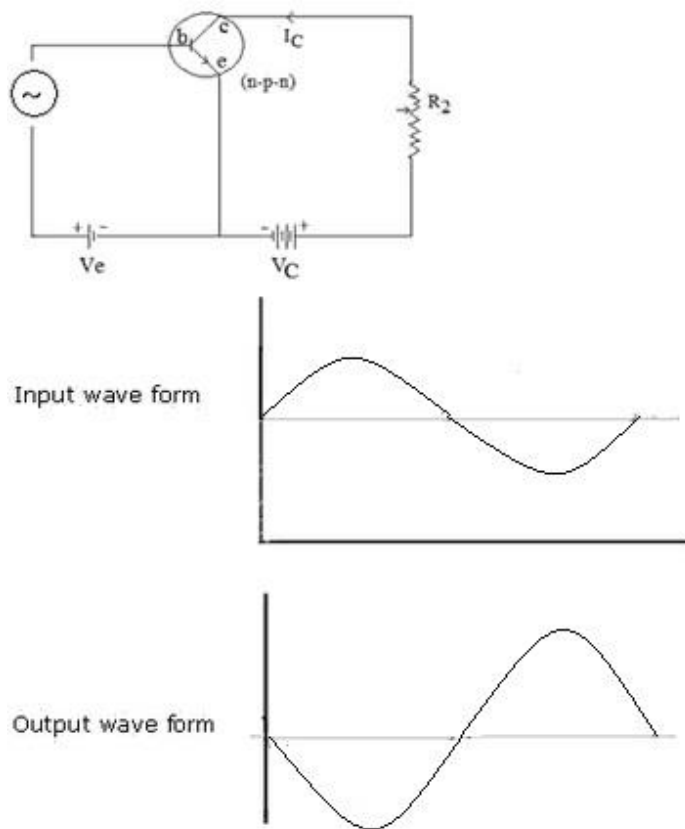

Relation – output waveform has 180° phase reversal as compared to input and also the output is being amplified.

9. Energy gap of the given intrinsic semiconductor, $E_g = 1.2 \text{ eV}$

The temperature dependence of the intrinsic carrier-concentration is written as:

$$n_i = n_0 \exp \left[-\frac{E_g}{2k_B T} \right]$$

Where k_B = Boltzmann constant = $8.62 \times 10^{-5} \text{ eV/K}$

T = Temperature

n_0 = Constant

Initial temperature, $T_1 = 300 \text{ K}$

The intrinsic carrier-concentration at this temperature can be written as:

$$n_{i1} = n_0 \exp \left[-\frac{E_g}{-2k_B \times 300} \right] \dots (1)$$

Final temperature, $T_2 = 600 \text{ K}$

The intrinsic carrier-concentration at this temperature can be written as:

$$n_{i2} = n_0 \exp \left[-\frac{E_g}{-2k_B \times 600} \right] \dots (2)$$

The ratio between the conductivities at 600 K and at 300 K is equal to the ratio between the respective intrinsic carrier-concentrations at these temperatures.

$$\begin{aligned} \frac{n_{i2}}{n_{i1}} &= \frac{n_0 \exp \left[-\frac{E_g}{2k_B 600} \right]}{n_0 \exp \left[-\frac{E_g}{2k_B 300} \right]} \\ &= \exp \frac{E_g}{2k_B} \left[\frac{1}{300} - \frac{1}{600} \right] \\ &= \exp \left[\frac{1.2}{2 \times 8.62 \times 10^{-5}} \times \frac{2-1}{600} \right] \\ &= \exp [11.6] = 1.09 \times 10^5 \end{aligned}$$

Therefore, the ratio between the conductivities is 1.09×10^5 .

- 10.** In a p-n junction diode, the expression for current is given as:

$$I = I_0 \exp \left(\frac{eV}{2k_B T} - 1 \right)$$

Where,

I_0 = Reverse saturation current = $5 \times 10^{-12} \text{ A}$

T = Absolute temperature = 300 K

K_B = Boltzmann constant = 8.6×10^{-5} eV / K = 1.376×10^{-23} JK⁻¹

V = Voltage across the diode

(a) Forward voltage, V = 0.6 V

$$\therefore \text{Current, } I = 5 \times 10^{-12} \left[\exp \left(\frac{1.6 \times 10^{-19} \times 0.6}{1.376 \times 10^{-23} \times 300} \right) - 1 \right]$$

$$= 5 \times 10^{-12} \times \exp[22.36] = 0.0256 \text{ A}$$

Therefore, the forward current is about 0.0256 A.

(b) For forward voltage, V' = 0.7 V, we can write:

$$= 5 \times 10^{-12} \left[\exp \left(\frac{1.6 \times 10^{-19} \times 0.7}{1.376 \times 10^{-23} \times 300} \right) - 1 \right]$$

$$= 5 \times 10^{-12} \times \exp[26.25] = 1.257 \text{ A}$$

Hence, the increase in current, $\Delta I = I' - I$

$$= 1.257 - 0.0256 = 1.23 \text{ A}$$

(c)

$$\text{Dynamic resistance} = \frac{\text{Change in voltage}}{\text{Change in current}}$$

$$= \frac{0.7 - 0.6}{1.23} = \frac{0.1}{1.23} = 0.081 \Omega$$

(e) If the reverse bias voltage changes from 1 V to 2 V, then the current (I) will almost remain equal to I_0 in both cases. Therefore, the dynamic resistance in the reverse bias will be infinite.

Assertion and Reason Answers –

1. (b) Both A and R are true but R is not the correct explanation of A.

Explanation:

In intrinsic semiconductor $\frac{n_e}{n_h} = 1$ and holes are not particles but vacancies created due to breakage of covalent bond.

2. (a) Both A and R are true and R is the correct explanation of A.

Explanation:

In half wave rectifier, the one diode is biased only when ac is in positive half of its cycle. For negative half of the ac cycle the diode is reversed biased and there is no output corresponding to that. Since for only one-half cycle we get a voltage output, because of which it is called half wave rectifier.

Case Study Answers –**1. Answer :**

(i) (a)

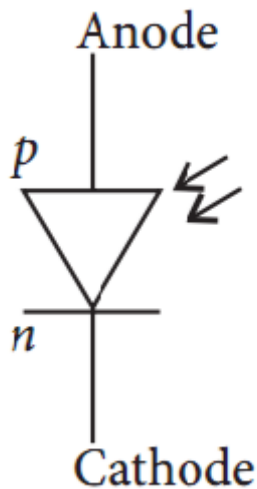

(ii) (c) Solar cell.

(iii) (a) Solar cell.

Explanation:

Solar cells are the source of energy for satellites.

(iv) (b) Silicon.

Explanation:

Silicon is used in solar cell.

(v) (b) 10 to 15%

2. Answer :

(i) (c) Electron concentration in n-region is more as compared to that in p-region.

Explanation:

Electron concentration in n-region is more as compared to that in p-region. So electrons diffuse from n-side to p-side.

(ii) (a) Light.

Explanation:

When an electron and a hole recombine, the energy is released in the form of light.

(iii) (a) Potential at p is equal to that at n.

Explanation:

In an unbiased p-n junction, potential at p is equal to that at n.

(iv) (c) Ions.

Explanation:

The potential of depletion layer is due to ions.

(v) (a) It is devoid of charge carriers.

Explanation:

In the depletion layer of unbiased p-n, junction has no charge carriers.